

MP-A 03

Part No. Plug: 3186-0001 Cable clamp: 2918-030*, 2918-060*

Product Specification

Qualification Test Report No. TR-15085

2	S21558	November 25, 2021	H.Takao	K.Yufu	M.Takemoto
1	S18739	November 21, 2018	S.Kawamura	K.Yufu	K.Yotsutani
0	S15475	October 9, 2015	S.Suzuki	T.Hirakawa	T.Takano
Rev.	ECN	Date	Prepared by	Checked by	Approved by

1. Scope

This product specification defines the test conditions and the performances of the MP-A 03

2. Product Name and Parts No.

2.1 Product Name

MP-A 03

2.2 Parts No.

3186-0001

3. Rating

3.1 Applicable Cable

3.1-1. Cable clamp (3mm) for $\phi 0.64$ coaxial cable (I-PEX P/N: 2918-030*)

3.1-2. Cable clamp (6mm) for $\phi 0.64$ coaxial cable (I-PEX P/N: 2918-060*)

Note : Only a similar cable is replaceable.

3.2 Operating Conditions

Operating temperature: 233 to 358K(-40°C to 85°C) (Containing temperature rise by current)

Operating humidity: 85% max

3.3 Storage Conditions

Storage temperature: 248 to 333K(-25°C to 60°C)

Storage humidity: 85% max. (Non-condensing)

4. Test and Performance

Test Condition

Unless otherwise specified, all tests and measurements shall be performed under the following conditions in accordance with MIL-STD-202.

Temperature: 288K to 308K(15°C to 35°C)

Pressure: 866hPa to 1066hPa(650mmHg to 800mmHg)

Relative humidity: 45 to 75% R.H.

4.1. Electrical Performance

1. Contact resistance

Reference standard: MIL-STD-202-307

Test conditions: Solder the clip to the test board and mate the test cable together, then apply 20mV MAX. DC open circuit voltage and 10mA MAX. DC closed circuit current. Measure the contact resistance of GROUND at the section shown in Fig.1 by the four terminal methods.
Test cable : Chapter 3 (3.1-1, 3.1-2)

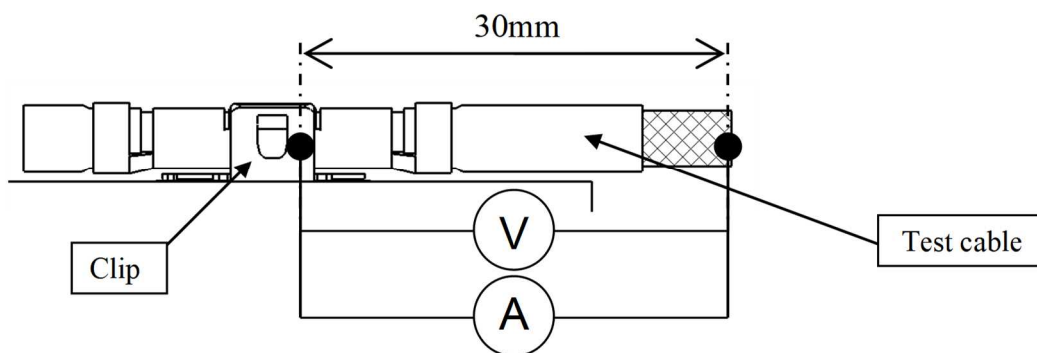

Fig.1

Pass criteria: Initial: 70 mΩ MAX.
After testing: 70 mΩ MAX.

4.2. Mechanical Performance

1. Mating force and Un-mating force	
Reference standard:	-
Test conditions:	Solder the clip to the test board, then place the board and plug on push-on/pull-off machine. Repeat mating/un-mating 5 cycles at a speed 25 ± 3 mm/min. in direction to show in Fig.2. Measure the mating and un-mating force at the initial and after 5cycles.
<p>Fig.2</p>	
Pass criteria:	Mating force Initial: 25 N MAX. 5cycles: 25 N MAX. Un-mating force Initial: 3 N MIN. 5cycles: 2 N MIN.

2. Durability	
Reference standard:	-
Test conditions:	Solder the clip to the test board, then place the board and test cable on the push-on/pull-off machine, and repeat mating and un-mating 5cycles at a speed 25 ± 3 mm/min. in direction to show in Fig.2.
Pass criteria:	Contact resistance: Shall meet 4.1.1 Appearance: No abnormality adversely affecting the performance shall occur.

3. Vibration	
Reference standard:	MIL-STD-202-201
Test conditions:	Solder the clip to the test board, then mate test cable, and place them on the vibrator. Then apply the following vibration. During the testing, run 100mA DC to check electrical discontinuity. Frequency: 10Hz→55Hz→10Hz/approx. 1min. Directions: 3 mutually perpendicular directions. Total Amplitude: 1.52mm Sweep duration: 2 hours for each direction, a total of 6 hours.
Pass criteria:	Contact resistance: Shall meet 4.1.1. Electrical discontinuity: No electrical discontinuity greater than 1μs shall occur. Appearance: No abnormality adversely affecting the performance shall occur.

6. Shock	
Reference standard:	MIL-STD-202-213, Test condition A.
Test conditions:	Solder the clip to the test board, then mate test cable, and place them on the shock machine. Then apply the following shock. MAX.G: 50G Duration: 11msec Wave Form: Half Sinusoidal Directions: 6 mutually perpendicular direction Cycle: 3 cycles each direction
Pass criteria:	Contact resistance: Shall meet 4.1.1. Electrical discontinuity: No electrical discontinuity greater than 1 μ s shall occur. Appearance: No abnormality adversely affecting the performance shall occur.

4.3. Environmental Performance

1. Thermal shock	
Reference standard:	MIL-STD-202-107, Test condition A.
Test conditions:	Solder the clip to the test board, then mate test cable, and expose them to the following environment. Temperature: 218K(-55°C),30min.→358K(85°C),30min. Transition time: 5min. MAX. Cycle: 5 cycles
Pass criteria:	Contact resistance: Shall meet 4.1.1. Appearance: No abnormality adversely affecting the performance shall occur.

2. High temperature life	
Reference standard:	MIL-STD-202-108, Test condition A.
Test conditions:	Solder the clip to the test board, then mate test cable, and expose them to the following environment. Temperature: 358 \pm 2K (85 \pm 2°C) Duration: 96 hours
Pass criteria:	Contact resistance: Shall meet 4.1.1. Appearance: No abnormality adversely affecting the performance shall occur.

3. Humidity (Steady state)	
Reference standard:	MIL-STD-202-103, Test condition B.
Test conditions:	Solder the clip to the test board, then mate test cable, and expose them to the following environment. Temperature: 313 \pm 2K (40 \pm 2°C) Humidity: 90~95%RH Duration: 96 hours
Pass criteria:	Contact resistance: Shall meet 4.1.1. Appearance: No abnormality adversely affecting the performance shall occur.

4. Low-temperature test	
Reference standard:	IEC-60068-2-1
Test conditions:	Solder the clip to the test board, then mate test cable, and expose them to the following environment. Temperature: 233 \pm 2K (-40 \pm 2°C) Duration: 48 hours
Pass criteria:	Contact resistance: Shall meet 4.1.1. Appearance: No abnormality adversely affecting the performance shall occur.

4.4. Others

1. Solderability	
Reference standard:	-
Test conditions:	Immerse the contact soldering part to flux of RMA type for 5 to 10 seconds, then dip the part into the solder bath of 518±5K (245±5°C) for 5±0.5seconds.
Pass criteria:	More than 95% of the dipped surface shall be evenly wet.

2. Resistance to soldering heat

Reference standard: -	
Test conditions:	Reflow temperature: See Fig.3. Cycle: 3

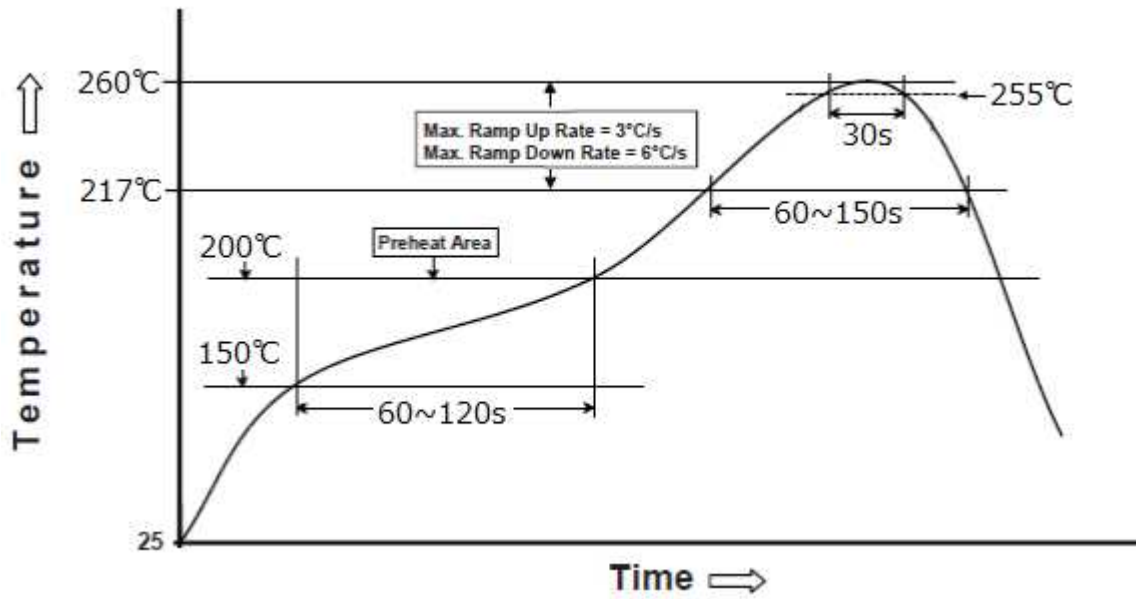

Fig.3

Pass criteria:	Contact resistance: Shall meet 4.1.1. Appearance: No abnormality adversely affecting the performance shall occur.
----------------	--

4.5 Test Sequence and Specimen Quantity

Table.1 Test Sequence and Sample Quantity

Test Item	Group									
	A	B	C	D	E	F	G	H	J	K
Contact resistance		1,3	1,3	1,3	1,3	1,3	1,3	1,3		2
Mating force	1,4									
Un-mating force	2,5									
Durability	3	2								
Vibration			2							
Shock				2						
Thermal shock					2					
High temperature life						2				
Humidity (Steady State)							2			
Low-temperature test								2		
Solder ability									1	
Soldering heat resistance										1
Specimen quantity.	10	10	5	5	5	5	5	5	5	5

※Numbers indicate test sequences.

5. Recommended Metal Mask

Refer to drawing for the recommended metal mask thickness and opening dimension.