

# MHF<sup>®</sup> I Connector

Ground contact gold plating  
(Anti-static reel version)

Part No. Plug: 20351-1\*\*R-37 Receptacle: 20279-001E-0\* / 20431-001E-01 / 20441-001E-01

## Product Specification

Qualification Test Report No. TR-12096

9	S23451	December 20, 2023	M.Toida	K. Yufu	Y. Hashimoto
8	S23421	November 28, 2023	K.Tanaka	K. Yufu	Y. Hashimoto
7	S21590	November 11, 2021	S.Taguchi	-	M.Takemoto
6	S20593	November 10, 2020	S.Taguchi	J.Tonai	M.Takemoto
Rev.	ECN	Date	Prepared by	Checked by	Approved by

## 1. Scope

This Product Specification defines the test conditions and the performances of the MHF I Connector.

## 2. Product Name and Parts No.

### 2.1 Product Name

MHF I Connector

### 2.2 Parts No.

Plug: 20351-1\*\*R-37

Receptacle: 20279-001E-0\*

20431-001E-01

20441-001E-01

## 3. Product Shape, Dimensions and Material.

Refer to the drawing

## 4. Rating

### 4.1 Applicable cable

#### (1) Description

Inner conductor : AWG#30(7/0.102)

Silver plating annealed copper wire or silver plating tin-copper alloy

Dielectric core : Fluoro-plastics , diameter 0.88mm , nominal thickness 0.29mm

Outer conductor : 16/5/0.05 , nominal diameter 1.13mm , tin plating annealed copper wire

Jacket : Fluoro-plastics , diameter 1.37mm , nominal thickness 0.12mm

#### (2) Requirements

Characteristic impedance :  $50(\pm 2)\Omega$  by TDR method

Nominal capacitance(Reference value): 98 pF/m

Conductor resistance of inner conductor at 293K (20°C)(Reference value) :  $320\Omega/\text{km}$

Insulation resistance :  $1,500 \text{ M}\Omega \cdot \text{km}$  MIN.

Dielectric withstand voltage : no breakdown at AC1,500V for 1 minutes.

### 4.2 Operating Condition

Voltage : 60V AC (per a contact)

Operating Temperature :  $233\sim 363\text{K}(-40^\circ\text{C}\sim +90^\circ\text{C})$

(Containing temperature rise by current)

Nominal characteristic impedance :  $50\Omega$

Frequency : DC~9.0GHz

VSWR : Plug: 1.3 MAX. at 0.1~3GHz , 1.5 MAX. at 3~6GHz, 1.9 MAX. at 6~9GHz

Receptacle: 1.3 MAX. at 0.1~3GHz. 1.4 MAX. at 3~6GHz, 1.8 MAX. at 6~9GHz

Storage condition : Temperature  $248\text{K}\sim 333\text{K}(-25^\circ\text{C}\sim +60^\circ\text{C})$

Humidity : 85% MAX. (No condensation)

## 5. Test and Performance

### Test Condition

This initial test is equal to it's at shipping condition and unless otherwise specified, all tests and measurements shall be performed under the following conditions in accordance with MIL-STD-202.

Temperature ...  $288\text{K}\sim 308\text{K} (15^\circ\text{C}\sim 35^\circ\text{C})$

Pressure ...  $866\text{hPa}\sim 1066\text{hPa} (650\text{mmHg}\sim 800\text{mmHg})$

Relative Humidity ...  $45\sim 75\% \text{R.H.}$

## 5.1. Electrical Performance

### 1. Contact resistance

Reference standard: MIL-STD-202G, Method 307  
 Test conditions: Solder the receptacle connector to the test board and mate the plug connector together, then measure the contact resistance as shown in Fig. 1 by the four terminal method.  
 Open circuit voltage: 20mV MAX  
 Circuit current: 10mA MAX.

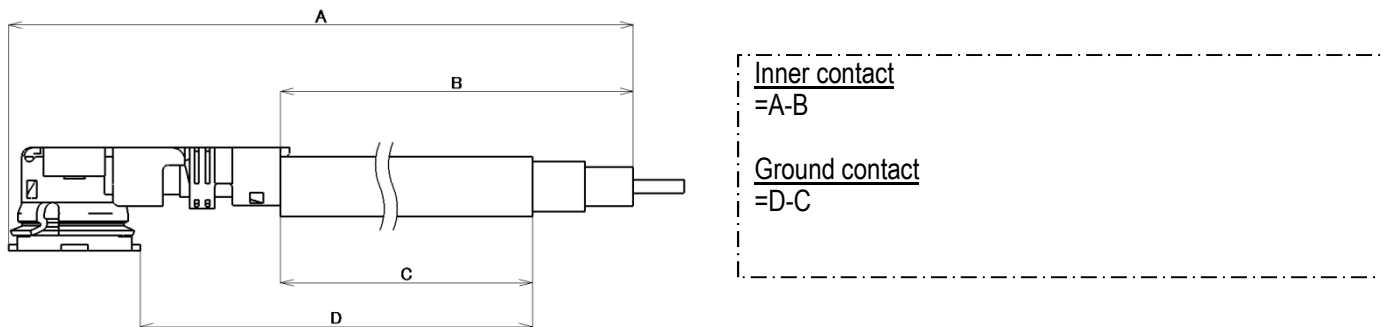

Fig. 1

Pass criteria: Inner contact Initial : 20mΩ MAX. After testing : 25mΩ MAX.  
 Ground contact Initial : 10mΩ MAX. After testing : 15mΩ MAX.

### 2. Insulation resistance

Reference standard: MIL-STD-202-302, Test condition A  
 Test conditions: Mate the plug and receptacle connector together, and then apply DC 100 V between the inner contact and the ground contact.

Pass criteria: Initial : 500 MΩ MIN.  
 After testing : 100 MΩ MIN.

### 3. Dielectric withstanding voltage

Reference standard: MIL-STD-202-301  
 Test conditions: Mate the receptacle and plug connector together, then apply AC 200V(rms) between the neighboring contacts for a minute.  
 Pass criteria: No abnormalities such as creeping discharge, flashover, insulator breakdown occur.

## 5.1. Electrical Performance

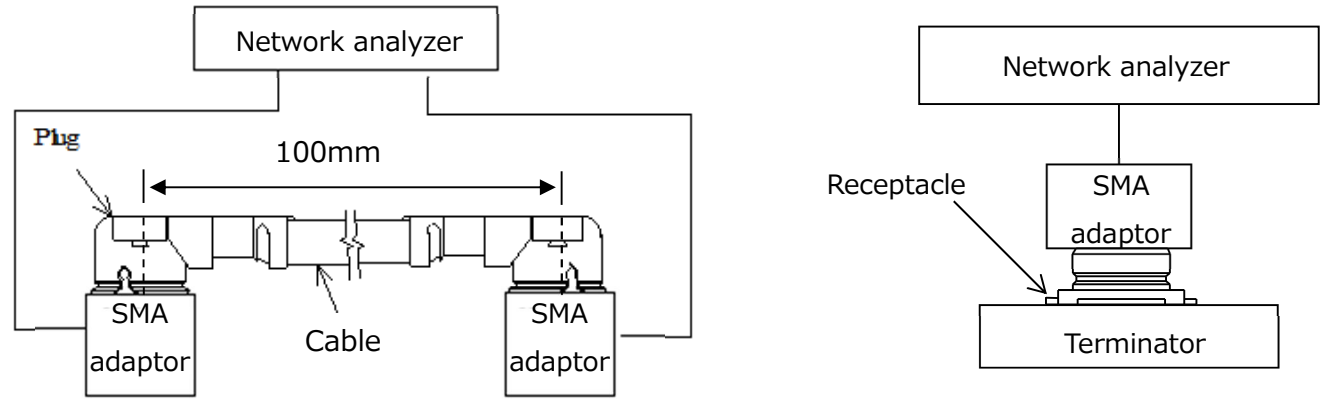
4. VSWR	
Reference standard:	
Test conditions:	Measure the VSWR as shown in Fig. 2 by the network analyzer. Frequency : 100MHz~9.0GHz
	
Fig. 2	
Pass criteria:	Plug 0.1~3GHz 1.3 MAX., 3~6GHz 1.5 MAX., 6~9GHz 1.9 MAX Receptacle 0.1~3GHz 1.3 MAX., 3~6GHz 1.4 MAX., 6~9GHz 1.8 MAX.

## 5.2. Mechanical Performance

1. Unmating force	
Reference standard:	-
Test conditions:	Solder the receptacle connector to the test board, then place the board and plug on push-on/pull-off machine, measure of initial and mating/un-mating 30 cycles at a speed $25 \pm 3$ mm/min. along the mating axis.
Pass criteria:	Total unmating force Initial: 5N Min. After 30 cycles: 3N Min. Unmating force of inner contact Initial: 0.15N Min. After 30 cycles: 0.10N Min.

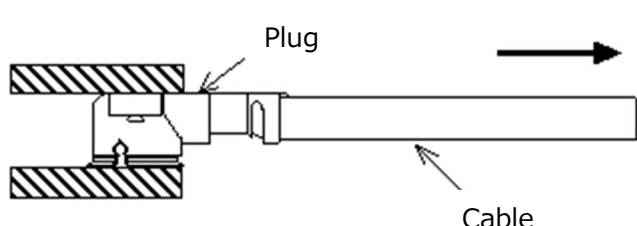
2. Crimp strength	
Reference standard:	-
Test conditions:	Pull the cable as shown in Fig. 3 at a speed $25 \pm 3$ mm/minutes by tensile strength machine.
	
Fig. 3	
Pass criteria:	15N MIN.

## 5.2. Mechanical Performance

3. Durability	
Reference standard:	-
Test conditions:	Solder the receptacle connector to the test board, then place the board and plug on the push-on/pull-off machine, and repeat mating and un-mating 30cycles at a speed $25\pm 3\text{mm/min}$ . along the mating axis.
Pass criteria:	[Contact Resistance] Shall meet 5.1.1.

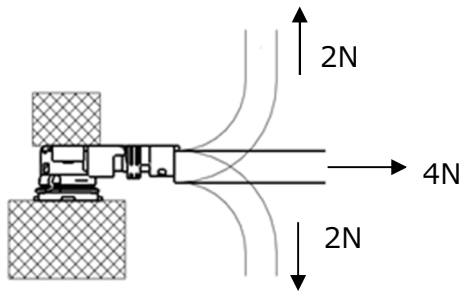
4. Cable retention force	
Reference standard:	-
Test conditions:	Apply force on the cable as shown in Fig. 4. During the testing, run 100mA DC to check electrical discontinuity.
 <p>Fig. 4</p>	
Pass criteria:	[Contact Resistance] Shall meet 5.1.1. [Electrical discontinuity] No electrical discontinuity greater than $1\mu\text{s}$ shall occur. [Appearance] No abnormality adversely affecting the performance shall occur.

5. Vibration	
Reference standard:	-
Test conditions:	Apply the following vibration to the mating connector. During the testing, run 100mA DC to check electrical discontinuity. Frequency: $10\text{Hz} \rightarrow 100\text{Hz} \rightarrow 10\text{Hz}$ / approx. 15 minutes. Half amplitude, Peak value of acceleration $1.5\text{mm}$ or $59\text{m/s}^2$ (6G) Directions, cycle 3 mutually perpendicular direction 5 cycles (approx. 75min) about each direction
Pass criteria:	[Contact Resistance] Shall meet 5.1.1. [Electrical discontinuity] No electrical discontinuity greater than $1\mu\text{s}$ shall occur. [Appearance] No abnormality adversely affecting the performance shall occur.

6. Shock	
Reference standard:	-
Test conditions:	Apply the following vibration to the mating connector. During the testing, run 100mA DC to check electrical discontinuity. Peak value of acceleration : $735\text{m/s}^2$ (75G) Duration: 11msec Wave Form: half sinusoidal Directions, cycle: 6 mutually perpendicular direction, 3 cycles about each direction
Pass criteria:	[Contact Resistance] Shall meet 5.1.1. [Electrical discontinuity] No electrical discontinuity greater than $1\mu\text{s}$ shall occur. [Appearance] No abnormality adversely affecting the performance shall occur.

## 5.3. Environmental Performance

1. Thermal Shock	
Reference standard:	-
Test conditions:	Apply the following environment to the mating connector. Temperature ,duration: 233K(-40°C)/30 minutes →278~308K(5~35°C)/5 minutes MAX. →363K(90°C)/30 minutes →278~308K(5~35°C)/5 minutes MAX.  Number of cycles : 5 cycles
Pass criteria:	[Contact Resistance] Shall meet 5.1.1. [Insulation Resistance] Shall meet 5.1.2. [Appearance] No abnormality adversely affecting the performance shall occur.

2. Humidity (Steady State)	
Reference standard:	MIL-STD-202G, Method 103, Condition B
Test conditions:	Solder the receptacle connector to the test board, then mate plug connector, and expose them to the following environment. Temperature: 313±2 K (40±2°C) Humidity: 90~95%RH Duration: 96 hours
Pass criteria:	[Contact Resistance] Shall meet 5.1.1. [Insulation Resistance] Shall meet 5.1.2. [Appearance] No abnormality adversely affecting the performance shall occur.

3. Salt Water Spray	
Reference standard:	MIL-STD-202G, Method 101, Condition B
Test conditions:	Solder the receptacle connector to the test board, then mate plug connector, and expose them to the following environment. Temperature: 308±2K (35±2°C) Salt water density: 5±1% [by weight] Duration: 48 hours
Pass criteria:	[Contact Resistance] Shall meet 5.1.1. [Appearance] No abnormality adversely affecting the performance shall occur.

4. High Temperature Life	
Reference standard:	-
Test conditions:	Apply the following environment to the mating connector. Temperature: 363±2K (90±2°C) Duration: 96 hours
Pass criteria:	[Contact Resistance] Shall meet 5.1.1. [[Appearance] No abnormality adversely affecting the performance shall occur.

## 5.4. Others

1. Solder ability	
Reference standard:	-
Test conditions:	Dip the solder tine of the contact in the solder bath at $518 \pm 5\text{K}$ ( $245 \pm 5^\circ\text{C}$ ) for $5 \pm 0.5$ seconds after immersing the tine in the flux of RMA or R type for 5 to 10 seconds.
Pass criteria:	More than 95% of the dipped surface shall be evenly wet.

2. Soldering Heat Resistance	
Reference standard:	-
Test conditions:	Put on the receptacle connector to PCB, apply the heat 2 cycles as shown in Fig. 5.
<p style="text-align: center;">Temperature</p> <p style="text-align: center;">Time</p> <p style="text-align: center;">Fig. 5</p>	
Pass criteria:	[Appearance] No abnormality adversely affecting the performance shall occur.

## 5.5 Test Sequence and Sample Quantity

**Table 1 Test Sequence and Sample Quantity**

Test Item	Group													
	A	B	C	D	E	F	G	H	J	K	L	M	N	P
Contact Resistance					1,3	1,3	1,3	1,3	1,4	1,4	1,3	1,3		
Insulation Resistance									2,5	2,5				
Dielectric Withstanding Voltage	1													
VSWR		1												
Unmating Force			1											
Crimp Strength				1										
Durability					2									
Cable Retention Force						2								
Vibration							2							
Shock								2						
Thermal Shock									3					
Humidity (Steady State)										3				
Salt Water Spray											2			
High Temperature Life												2		
Solder ability													1	
Soldering Heat Resistance														1
Sample Quantity	10	5	10	10	10	10	10	10	10	10	10	10	10	10

Numbers indicate sequence in which tests are performed.

## 6. Recommended Metal Mask

Refer to drawing for the recommended metal mask thickness and opening dimension.