

MHF® 5 Connector (AWG#36φ0.64 Cable)

Part No. Plug:20711-001R-81 Receptacle:20566-001E-01

Product Specification

Qualification Test Report No. TR-15063

2	S21522	October 27, 2021	K. Ikeshita		M. Takemoto
1	S17480	June 27, 2017	M.A		T.M
0	S15359	August 21, 2015	T.Yayoshi	K.Yotsutani	E.Kawabe
Rev.	ECN	Date	Prepared by	Checked by	Approved by

1. Scope
This product specification defines the test conditions and the performances of the MHF 5 Connector AWG#36φ0.64 Cable.

2. Product Name and Parts No.

2.1 Product Name
MHF 5 Connector

2.2 Parts No.
Plug: 20711-001R-81
Receptacle: 20566-001E-01

3. Rating

3.1 Applicable Cable

- (1) Description
 Inner conductor : AWG#36(7/0.05) ,Silver plating annealed copper wire
 Dielectric core : Fluoro-plastics ,diameter 0.44(+0.02,-0.02)mm , nominal thickness 0.145mm
 Outer conductor : Nominal diameter 0.54mm , silver plating annealed copper wire or tin plating annealed copper wire
 Jacket : Fluoro-plastics , diameter 0.64(+0.02,-0.02)mm , nominal thickness 0.05mm
- (2) Requirements
 Characteristic impedance : 50(+5,-5)ohm by TDR method
 Nominal capacitance (Reference value) : 96 pF/m
 Conductor resistance of inner conductor at 293K (20°C) : 1400 ohm/km MAX.
 Insulation resistance : 1000 mega-ohm·km MIN.
 Dielectric withstand voltage : no breakdown at AC500V for 1 minutes.

3.2 Operating Conditions

Rated voltage	AC60Vr.m.s
Nominal characteristic impedance	50 ohm.
Frequency	DC~6GHz
VSWR	Plug : 1.3 MAX. (DC~3HGz) , 1.5 MAX. (3~6GHz) Receptacle : 1.3 MAX. (DC~3HGz) , 1.4 MAX. (3~6GHz)
Service Temperature	233K~363K (-40°C~90°C)

3.3 Storage Conditions

Storage temperature: 248 to 333K(-25°C to 60°C)
 Storage humidity: 85% max. (Non-condensing)

4. Test and Performance

Test Condition
 Unless otherwise specified, all tests and measurements shall be performed under the following conditions in accordance with MIL-STD-202.

Temperature: 288K to 308K(15°C to 35°C)
 Pressure: 866hPa to 1066hPa(650mmHg to 800mmHg)
 Relative humidity: 45 to 75% R.H.

4.1. Electrical Performance 4.1. Electrical Performance

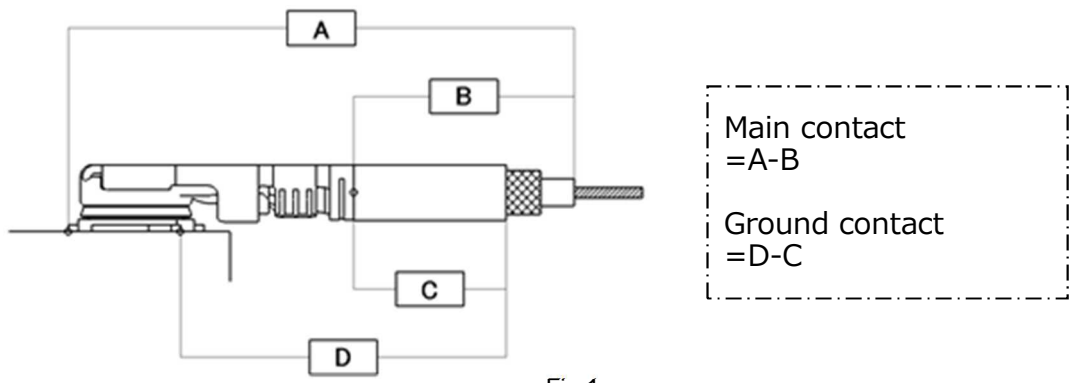
1. Contact Resistance	
Reference standard:	MIL-STD-202-307
Test conditions:	Solder the receptacle connector to the test board and mate the plug connector together, then measure the contact resistance as shown in Fig. 1 by the four terminal methods. Apply the low level condition. Open circuit voltage: 20mV MAX. Circuit current: 10mA MAX.
	
Fig.1	
Pass criteria:	Inner contact Initial : 20mΩ MAX. After testing : ΔR20mΩ MAX. Ground contact Initial : 20mΩ MAX. After testing : ΔR100mΩ MAX.

2. Insulation Resistance	
Reference standard:	MIL-STD-202-302
Test conditions:	Mate the plug and receptacle connector together, and then apply DC 100 V between the inner contact and the ground contact.
Pass criteria:	Initial: 500 MΩ MIN. After testing: 100 MΩ MIN.

3. D. W. Voltage	
Reference standard:	MIL-STD-202-301
Test conditions:	Mate the plug and receptacle connector together, then apply AC 200V(rms) between the inner contact and the ground contact for a minute.
Pass criteria:	No abnormalities such as creeping discharge, flashover, insulator breakdown occur.

4.1. Electrical Performance

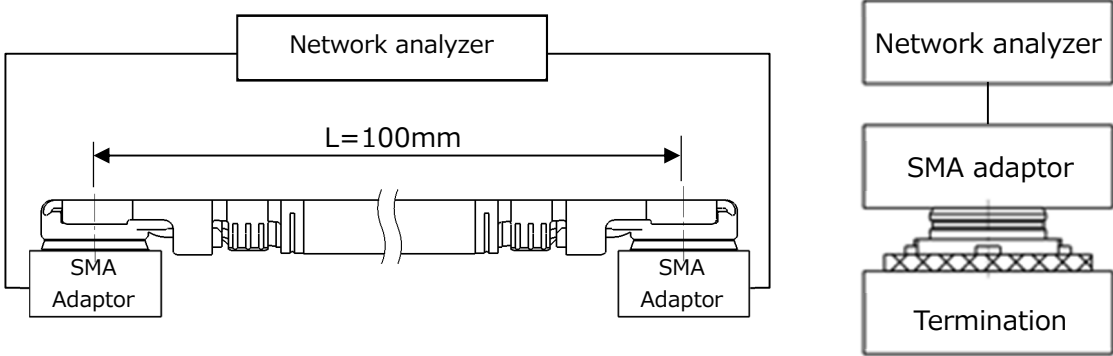
4. VSWR	
Reference standard:	-
Test conditions:	Measure the VSWR as shown in Fig. 2 by the network analyzer. Frequency: 100MHz~6GHz
	
Fig. 2	
Pass criteria:	PLUG: 1.3 MAX. at 0.1~3GHz, 1.5 MAX. at 3~6GHz RECEPTACLE: 1.3 MAX. at 0.1~3GHz, 1.4 MAX. at 3~6GHz

4.2. Mechanical Performance

1. Unmating force	
Reference standard:	-
Test conditions:	Solder the receptacle connector to the test board, then place the board and plug on push-on/pull-off machine, measure of initial and un-mating 30 cycles at a speed 25 ± 3 mm/min. along the mating axis.
Pass criteria:	Initial: 4 N MIN. After 30cycles: 2 N MIN.

2. Durability	
Reference standard:	-
Test conditions:	Solder the receptacle connector to the test board, then place the board and plug on the push-on/pull-off machine, and repeat mating and un-mating 30cycles at a speed 25 ± 3 mm/min. along the mating axis.
Pass criteria:	Contact resistance: Shall meet 4.1.1. Appearance: No abnormality adversely affecting the performance shall occur.

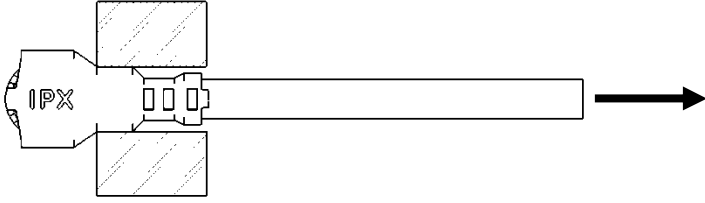
3. Crimp Strength	
Reference standard:	-
Test conditions:	Pull the cable as shown in Fig-3 at speed of 25 ± 3 mm/minutes by the tensile strength machine and measure the retention force.
	
Fig. 3	
Pass criteria:	7N MIN.

4.2. Mechanical Performance

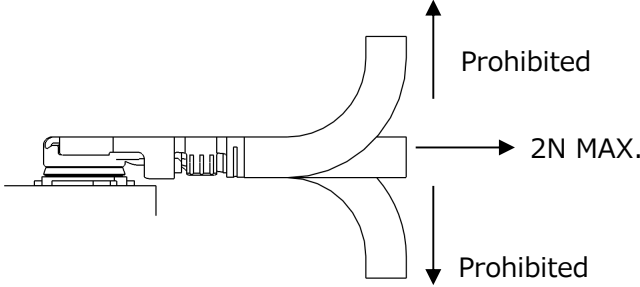
4. Cable Retention Force	
Reference standard:	-
Test conditions:	Apply force to the cable as shown in Fig. 4. During the testing, run 100mA DC to check electrical discontinuity.
 <p>The diagram shows a cross-section of a cable connector assembly. A horizontal force arrow points to the right from the center of the cable, labeled '2N MAX.'. Two vertical arrows, one pointing up and one pointing down, are positioned to the right of the cable, both labeled 'Prohibited', indicating that pulling the cable up or down is not allowed during the test.</p>	
Fig. 4	
Pass criteria:	Electrical discontinuity: No electrical discontinuity greater than 1μs shall occur. Appearance: Looseness between the parts, chipping, breakage or other abnormality shall not occur.

5. Vibration	
Reference standard:	-
Test conditions:	Apply the following vibration to the mating connector. During the testing, run 100mA DC to check electrical discontinuity. Frequency: 10Hz → 100Hz → 10Hz / approx. 15 minutes. Half amplitude, Peak value of acceleration: 1.5mm or 59m/s ² (6G) Directions, cycle: 3 mutually perpendicular direction, 3 cycles for each direction.
Pass criteria:	Contact resistance: Shall meet 4.1.1. Electrical discontinuity: No electrical discontinuity greater than 1μs shall occur. Appearance: No abnormality adversely affecting the performance shall occur

6. Shock	
Reference standard:	MIL-STD-202-213, Test condition B.
Test conditions:	Apply the following vibration to the mating connector. During the testing, run 100mA DC to check electrical discontinuity. Peak value of acceleration : 735m/s ² (75G) Duration: 11msec Wave Form: half sinusoidal Directions, cycle: 6 mutually perpendicular direction, 3 cycles about each direction
Pass criteria:	Contact resistance: Shall meet 4.1.1. Electrical discontinuity: No electrical discontinuity greater than 1μs shall occur. Appearance: No abnormality adversely affecting the performance shall occur

4.3. Environmental Performance

1. Humidity (Steady state)	
Reference standard:	MIL-STD-202-103, Test condition B.
Test conditions:	Solder the receptacle connector to the test board, then mate plug connector, and expose them to the following environment. Temperature: $313\pm 2\text{K}$ ($40\pm 2^\circ\text{C}$) Humidity: 90~95%RH Duration: 96 hours
Pass criteria:	Contact resistance: Shall meet 4.1.1. Insulation resistance: Shall meet 4.1.2. Dielectric withstanding voltage: Shall meet 4.1.3. Appearance: No abnormality adversely affecting the performance shall occur

2. Thermal Shock	
Reference standard:	MIL-STD-202-107, Test condition A.
Test conditions:	Solder the receptacle connector to the test board, then mate plug connector, and expose them to the following environment. Temperature: $218\text{K}(-55^\circ\text{C}), 30\text{min.} \rightarrow 358\text{K}(85^\circ\text{C}), 30\text{min.}$ Transition time: 5min. MAX. Cycle: 5 cycles
Pass criteria:	Contact resistance: Shall meet 4.1.1. Insulation resistance: Shall meet 4.1.2. Dielectric withstanding voltage: Shall meet 4.1.3. Appearance: No abnormality adversely affecting the performance shall occur

3. High Temperature Life	
Reference standard:	-
Test conditions:	Apply the following environment to the mating connector. Temperature : $363\pm 2\text{K}$ ($90\pm 2^\circ\text{C}$) Duration : 96 hours
Pass criteria:	Contact resistance: Shall meet 4.1.1. Appearance: No abnormality adversely affecting the performance shall occur

4. H₂S Gas	
Reference standard:	-
Test conditions:	Apply the following environment to the mating connector. Temperature: $313\pm 2\text{K}$ ($40\pm 2^\circ\text{C}$) Relative Humidity: $80\pm 5\%$ RH Gas: H ₂ S $3\pm 1\text{ppm}$ Duration: 96 hours
Pass criteria:	Contact resistance: Shall meet 4.1.1. Appearance: No abnormality adversely affecting the performance shall occur

4.3. Environmental Performance

5. Salt Water Spray	
Reference standard:	MIL-STD-202-101, Test condition B.
Test conditions:	Solder the receptacle connector to the test board, then mate plug connector, and expose them to the following environment. Temperature: 308±2K (35±2°C) Saltwater density: 5±1% [by weight] Duration: 48 hours
Pass criteria:	Contact resistance: Shall meet 4.1.1. Appearance: No abnormality adversely affecting the performance shall occur

4.4. Others

1. Solder ability	
Reference standard:	MIL-STD-202-208
Test conditions:	Immerse the contact soldering part to flux of RMA or R type for 5 to 10 seconds, then dip the part into the solder bath of 518±5K (245±5°C) for 5±0.5seconds.
Pass criteria:	More than 95% of the dipped surface becomes wet and the pinhole that should not gather at one point is less than 5%.

2. Soldering Heat Resistance																
Reference standard:	-															
Test conditions:	Reflow temperature profile: Fig. 5 The number of reflow is 2 times.															
<table border="1" style="float: right; margin-top: 10px;"> <thead> <tr> <th>Condition</th> <th>Temperature</th> <th>Time [s]</th> </tr> </thead> <tbody> <tr> <td>Condition 1</td> <td>403~453K (130~180°C)</td> <td>120MAX.</td> </tr> <tr> <td>Condition 2</td> <td>493K (220°C)</td> <td>60MAX.</td> </tr> <tr> <td>Condition 3</td> <td>503L (230°C)</td> <td>50MAX.</td> </tr> <tr> <td>Condition 4</td> <td>523K (250°C)</td> <td>10</td> </tr> </tbody> </table>		Condition	Temperature	Time [s]	Condition 1	403~453K (130~180°C)	120MAX.	Condition 2	493K (220°C)	60MAX.	Condition 3	503L (230°C)	50MAX.	Condition 4	523K (250°C)	10
Condition	Temperature	Time [s]														
Condition 1	403~453K (130~180°C)	120MAX.														
Condition 2	493K (220°C)	60MAX.														
Condition 3	503L (230°C)	50MAX.														
Condition 4	523K (250°C)	10														
<p>Fig. 5</p>																
Pass criteria:	No deformation nor defect adversely affecting the performance occur.															

4.5 Test Sequence and Specimen Quantity

Table.1 Test Sequence and Sample Quantity

Test Item	Group													
	A	B	C	D	E	F	G	H	J	K	L	M	N	P
Contact Resistance			1, 3			1, 3	1, 3	1, 5	1, 5	1, 3	1, 3	1, 3		
Insulation Resistance								2, 6	2, 6					
D. W. Voltage								3, 7	3, 7					
VSWR	1													
Unmating force		1												
Durability			2											
Crimp Strength				1										
Cable Retention Force					1									
Vibration						2								
Shock							2							
Humidity (Steady State)								4						
Thermal Shock									4					
High Temperature Life										2				
H2S Gas											2			
Salt Water Spray												2		
Solder ability													1	
Soldering Heat Resistance														1
Specimen quantity	10	10	10	10	10	10	10	10	10	10	10	10	10	10

Numbers indicate sequence in which tests are performed.

5. Recommended Metal Mask

Refer to drawing for the recommended metal mask thickness and opening dimension