

MHF[®] 4L Connector

Part No. Plug:20632-001R-37 Receptacle:20579-001E-**

Product Specification

Qualification Test Report No. TR-24070

Rev.	ECN	Date	Prepared by	Checked by	Approved by
0	S24513	December 19, 2024	K. Ikeshita	-	K. Yufu

1. Scope

This Product Specification defines the test conditions and the performances of the MHF 4L connector

2. Product Name and Parts No.

2.1 Product Name

MHF 4L PLUG
MHF 4L RECEPTACLE

2.2 Parts No.

Plug: 20632-001R-37
Receptacle: 20579-001E-**

3. Rating

3.1 Applicable Cable

Inner conductor: AWG#30(7/0.102), Silver plating annealed copper wire
Dielectric core: Fluoro-plastics, diameter 0.9(±0.05)mm , nominal thickness 0.29mm
Outer conductor: nominal diameter 1.13mm , silver plating annealed copper wire or tin-copper alloy
Jacket: Fluoro-plastics , diameter 1.37(±0.05)mm , nominal thickness 0.12mm

(2)Requirements

Characteristic impedance : 50(+2,-2)ohm by TDR method
Nominal capacitance (Reference value) : 98 pF/m
Conductor resistance of inner conductor at 293K (20°C) : 320 ohm/km.
Dielectric withstand voltage : no breakdown at AC1000V for 1 minutes.

3.2 Operating Conditions

Voltage: 60V AC (per contact pin)
Operating temperature: 233~363K(-40°C~90°C)
(Containing temperature rise by current)
Nominal characteristic impedance : 50Ω
Frequency: DC~12.0GHz
VSWR: [PLUG] 1.30 MAX at 0.1~3GHz. 1.40 MAX at 3~6GHz.
1.50 MAX at 6~9GHz. 1.60 MAX at 9~12GHz.
[RECEPTACLE] 1.30 MAX at 0.1~3GHz. 1.40 MAX at 3~6GHz.
1.50 MAX at 6~9GHz. 1.65 MAX at 9~12GHz

4. Test and Performance

Test Condition

This initial test is equal to it's at shipping condition and unless otherwise specified, all tests and measurements shall be performed under the following conditions in accordance with MIL-STD-202.

Temperature... 288K~308K (15°C~35°C)
Pressure... 866hPa~1066hPa (650mmHg~800mmHg)
Relative humidity... 45~75%R.H.

4.1. Electrical Performance

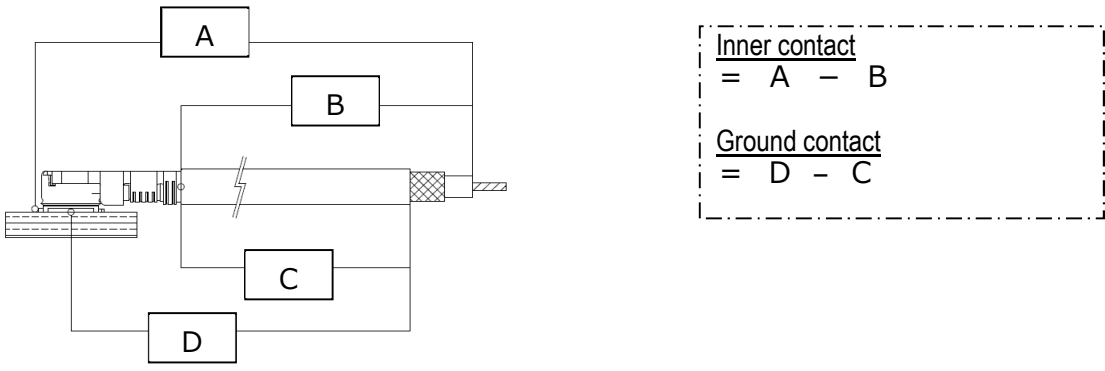
1. Contact resistance	
Reference standard:	MIL-STD-202-307
Test conditions:	Solder the receptacle connector to the test board and mate the plug connector together, then measure the contact resistance as shown in Fig.1 by the four terminal methods. Apply the low level condition of 20mV MAX. DC for the open circuit voltage and 10mA MAX. DC for the closed circuit current.
	
Fig.1	
Pass criteria:	Contact Initial: 20 mΩ MAX. After testing: $\triangle R$ 20 mΩ MAX. Ground contact Initial: 20 mΩ MAX. After testing: $\triangle R$ 20 mΩ MAX.

2. Insulation resistance	
Reference standard:	MIL-STD-202-302
Test conditions:	Mate the plug and receptacle connector together, and then apply DC 100 V between the inner contact and the ground contact.
Pass criteria:	Initial: 500 MΩ MIN. After testing: 100 MΩ MIN.

3. Dielectric withstanding voltage	
Reference standard:	MIL-STD-202-301
Test conditions:	Mate the receptacle and plug connector together, then apply AC 200V(rms) between the neighboring contacts for a minute.
Pass criteria:	No creeping discharge, flashover, no insulator breakdown shall occur.

4.1. Electrical Performance

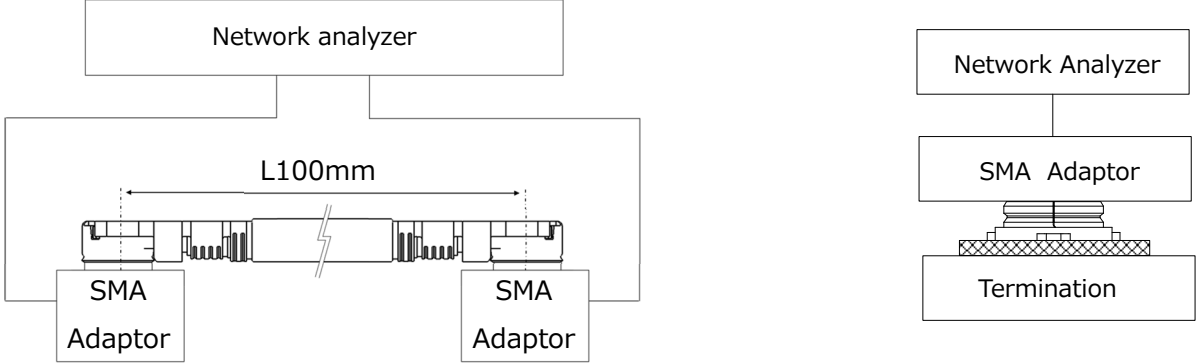
4. VSWR	
Reference standard:	-
Test conditions:	Measure the VSWR as shown in Fig. 2 by the network analyzer. Frequency : 100MHz~12.0GHz
 <p style="text-align: center;">Fig.2</p>	
Pass criteria:	Plug: 1.30 MAX.at 0.1~3GHz, 1.40 MAX.at 3~6GHz 1.50 MAX.at 6~9GHz, 1.60 MAX.at 9~12GHz Receptacle: 1.30 MAX.at 0.1~3GHz, 1.40 MAX.at 3~6GHz, 1.50 MAX.at 6~9GHz, 1.65 MAX at 9~12GHz

4.2. Mechanical Performance

1. Mating force / Unmating force	
Reference standard:	-
Test conditions:	Solder the receptacle connector to the test board, then place the board and plug on push-on/pull-off machine, measure of initial mating/unmating 30 cycles mating at a speed 25 ± 3 mm/min. along the mating axis.
Pass criteria:	Mating force Initial: 30 N MAX. 30cycles: 30 N MAX. Unmating force Initial: 20 N MAX. , 5 N MIN. 30cycles: 20 N MAX. , 3 N MIN..

2. Durability	
Reference standard:	-
Test conditions:	Solder the receptacle connector to the test board, then place the board and plug on the push-on/pull-off machine, and repeat mating and unmating 30cycles at a speed 25 ± 3 mm/min. along the mating axis.
Pass criteria:	Contact resistance: Shall meet 4.1.1 Appearance: No abnormality adversely affecting the performance shall occur.

4.2. Mechanical Performance

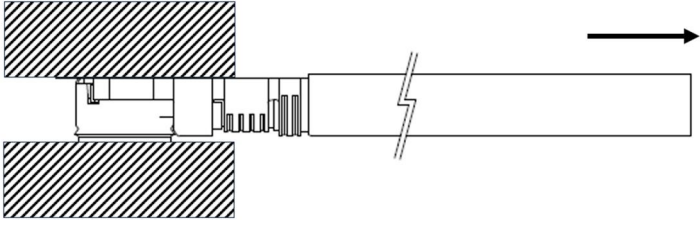
3. Cable retention force	
Reference standard:	-
Test conditions:	Pull the cable as shown in Fig. 5 at speed of 25±3mm/minutes by the tensile strength machine and measure the retention force.
	
Fig.5	
Pass criteria:	15 N MIN.

4. Vibration	
Reference standard:	MIL-STD-202-201
Test conditions:	Solder the receptacle connector to the test board, then mate plug connector, and place them on the vibrator. Then apply the following vibration. During the testing, run 100mA DC to check electrical discontinuity. Frequency: 10Hz→100Hz→10Hz/approx. 15min. Half amplitude, Peak value of acceleration : 1.5mm or 59m/s ² (6G) Directions , cycle : 3 mutually perpendicular direction, 5 cycles (approx. 75minutes.) for each direction.
Pass criteria:	Contact resistance: Shall meet 4.1.1. Electrical discontinuity: No electrical discontinuity greater than 1µs shall occur. Appearance: No abnormality adversely affecting the performance shall occur

5. Shock	
Reference standard:	MIL-STD-202-213, Condition A
Test conditions:	Solder the receptacle connector to the test board, then mate plug connector, and place them on the shock machine. Then apply the following shock. MAX.G: 75G Duration: 11msec Wave Form: Half Sinusoidal Directions: 6 mutually perpendicular direction Cycle: 3 cycles about each direction
Pass criteria:	Contact resistance: Shall meet 4.1.1. Electrical discontinuity: No electrical discontinuity greater than 1µs shall occur. Appearance: No abnormality adversely affecting the performance shall occur

4.3. Environmental Performance

1. Thermal shock	
Reference standard:	MIL-STD-202-107, Condition A
Test conditions:	Solder the receptacle connector to the test board, then mate plug connector, and expose them to the following environment. Temperature: 218K(-55°C),30min.→358K(85°C),30min. Transition time: 5min. MAX. No. of cycles: 5 cycles
Pass criteria:	Contact resistance: Shall meet 4.1.1. Insulation resistance: Shall meet 4.1.2. Dielectric withstanding voltage: Shall meet 4.1.3. Appearance: No abnormality adversely affecting the performance shall occur

2. High temperature life	
Reference standard:	MIL-STD-202-108, Condition B
Test conditions:	Solder the receptacle connector to the test board, then mate plug connector, and expose them to the following environment. Temperature: 358±2K (85±2°C) Duration: 96 hours
Pass criteria:	Contact resistance: Shall meet 4.1.1. Contact retention force: Shall meet 4.2.3. Appearance: No abnormality adversely affecting the performance shall occur

3. Humidity(Steady state)	
Reference standard:	MIL-STD-202-103, Condition A
Test conditions:	Solder the receptacle connector to the test board, then mate plug connector, and expose them to the following environment. Temperature: 313±2K (40±2°C) Humidity: 90~95%RH Duration: 96 hours
Pass criteria:	Contact resistance: Shall meet 4.1.1. Insulation resistance: Shall meet 4.1.2. Dielectric withstanding voltage: Shall meet 4.1.3. Appearance: No abnormality adversely affecting the performance shall occur

4. Salt water spray	
Reference standard:	-
Test conditions:	Solder the receptacle connector to the test board, then mate plug connector, and expose them to the following environment. Temperature: 308±2K (35±2°C) Salt water density: 5±1% [by weight] Duration: 48 hours
Pass criteria:	Contact resistance: Shall meet 4.1.1. Appearance: No abnormality adversely affecting the performance shall occur

4.3. Environmental Performance

5. H ₂ S gas	
Reference standard:	-
Test conditions:	Solder the receptacle connector to the test board, then mate plug connector, and expose them to the following environment. Temperature: 313±2K (40±2°C) Relative humidity: 80±5%RH Gas: H ₂ S 3±1ppm Duration: 48 hours
Pass criteria:	Contact resistance: Shall meet 4.1.1. Appearance: No abnormality adversely affecting the performance shall occur.

4.4. Others

1. Solder ability	
Reference standard:	-
Test conditions:	Dip the solder tine of the contact in the solder bath at 518±5K (245±5°C) for 5±0.5seconds after immersing the tine in the flux of RMA or R type for 5 to 10 seconds.
Pass criteria:	More than 95% of the dipped surface shall be evenly wet.

2. Soldering heat resistance	
Reference standard:	-
Test conditions:	Reflow temperature as shown in Fig.6. The number of times of Reflow is within 2.
<p>The graph shows a reflow temperature profile with two distinct heat cycles. The first cycle starts with a ramp up to a plateau at 403-443K (130-170°C), which lasts for 60-120 seconds. This is followed by a second cycle that ramps up to a higher peak of 553K (260°C) and remains at that temperature for 10±5 seconds before cooling down. Dashed lines indicate the peak temperatures and the duration of the second cycle.</p>	
Fig.6	
Pass criteria:	No abnormality adversely affecting the performance shall not occur.

4.5 Test Sequence and Specimen Quantity

Details of the Testing Groups A to Q are indicated in test report.

Table.1 Test Sequence and Sample Quantity

No.		Test Item	Testing Groups														
			A	B	C	D	E	F	G	H	J	K	L	M	N	P	Q
4.1 Electrical Performance	1	Contact resistance					1,3		1,3	1,3	1,5	1,5	1,3	1,3	1,3		
	2	Insulation resistance									2,6	2,6					
	3	Dielectric withstanding voltage	1								3,7	3,7					
	4	VSWR		2													
4.2 Mechanical Performance	1	Mating force			1												
		Unmating force				1											
	2	Durability					2										
	3	Cable retention force						1									
	4	Vibration							2								
	5	Shock								2							
4.3 Environmental Performance	1	Humidity(Steady State)									4						
	2	Thermal Shock										4					
	3	High Temperature Life											2				
	4	H2S Gas												2			
	5	Salt Water Spray														2	
4.4 Others	1	Solder ability															1
	2	Soldering heat resistance															1
Specimen quantity			10	10	10	10	10	10	10	10	10	10	10	10	10	10	10

※Numbers indicate test sequences.