

MHF[®]-SW23 ASS'Y

Part No. 20549-001E-**

Product Specification

Qualification Test Report No. TR-12041

7	S26176	May 15, 2026	Y. Nishimura	H. Takao	K. Yufu
6	S21532	October 26, 2021	K.Motomura	K.Yufu	M.Takemoto
5	S20232	April 23, 2020	K.Motomura	K.Yufu	Y.Hashimoto
4	S18270	April 30, 2018	M.Nomoto	K.Yufu	K.Yotsutani
Rev.	ECN	Date	Prepared by	Checked by	Approved by

1. Scope

This product specification defines the test conditions and the performances of the MHF-SW23 ASS'Y

2. Product Name and Parts No.

2.1 Product Name

MHF-SW23 ASS'Y

2.2 Parts No.

20549-001E-**

3. Product Shape, Dimensions and Material

Refer to the drawing. (Drawing No. 20549)

4. Rating

Table 1

	On state (Not mated with the plug)
Rated power	2W
Frequency	DC to 11.0GHz
VSWR	1.2 MAX. (DC to 2.5GHz) 1.3 MAX. (2.5GHz to 6.0GHz) 1.5 MAX. (6.0GHz to 11.0GHz)
Insertion Loss	0.15dB MAX. (DC to 2.5GHz) 0.20dB MAX. (2.5GHz to 6.0GHz) 0.40dB MAX. (6.0GHz to 11.0GHz)
Isolation	20dB MIN. (DC to 3.0GHz) 15dB MIN. (3.0GHz to 6.0GHz) 12dB MIN. (6.0GHz to 11.0GHz)
Service condition	Temperature : 233K to 358K (-40°C to +85°C) Humidity : 90% MAX. Containing temperature rise by energizing
Storage condition	Temperature : 243K to 343K (-30°C to +70°C) Humidity : 90% MAX. Non condensing

5. Test and Performance

5.1 Test Condition

This initial test is equal to it's at shipping condition and unless otherwise specified, all tests and measurements shall be performed under the following conditions in accordance with MIL-STD-202 G.

Temperature... 288K to 308K (15°C to 35°C)

Relative humidity... 45 to 75%R.H.

5.2 Electrical Performance

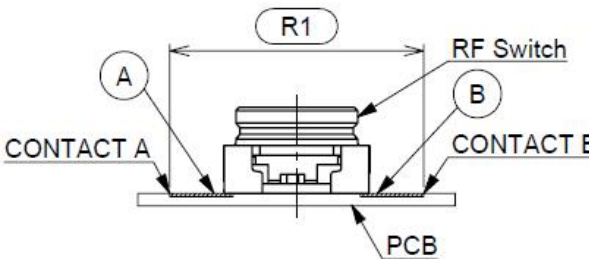
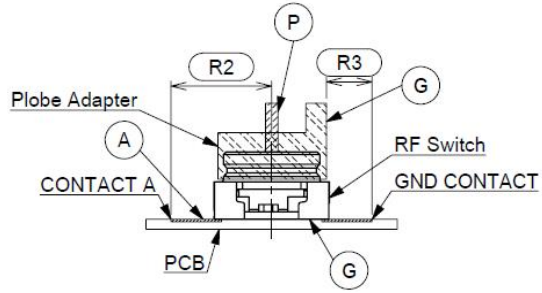
1. Contact resistance	
Reference standard:	MIL-STD-202-307
Test conditions:	Measure the contact resistance as shown in Fig.1 & 2 by the four terminal method. Apply the low level condition of 20mV max. DC for the open circuit voltage and 10mA max. DC for the closed circuit current.
	
Fig. 1 On state : Contact Resistance	Fig. 2 Off state: Contact Resistance
Pass criteria:	[Inner contact(R1,R2)]: 100mΩ MAX. [GND contact(R3)]: 100mΩ MAX.

2. Insulation resistance	
Reference standard:	MIL-STD-202-302, Condition A
Test conditions:	DC100V is applied and measured between a center contact and ground contact.
Pass criteria:	Initial: 1000MΩ MIN. After test: 10MΩ MIN.

3. Dielectric withstanding voltage	
Reference standard:	MIL-STD-202-301
Test conditions:	Apply AC100V between the center contact and the ground contact for a minute.
Pass criteria:	Without damage such as arcing or breakdown etc.

5.2 Electrical Performance

4. VSWR (Voltage Standing Wave Ratio)	
Reference standard:	-
Test conditions:	Measure the VSWR by the network analyzer as shown in Fig. 3. Frequency: 300KHz to 11GHz
Fig. 3 On state VSWR, Insertion Loss	
Pass criteria:	[On state] 1.2 MAX. (300 KHz to 2.5 GHz) 1.3 MAX. (2.5 GHz to 6.0 GHz) 1.5 MAX. (6.0 GHz to 11.0 GHz)

5. Insertion Loss	
Reference standard:	-
Test conditions:	Measure the insertion loss as shown in Fig. 3 above by the network analyzer. Deduct the characteristic of the test fixture from result of a measurement. Frequency : 300KHz to 11GHz
Pass criteria:	[On state] 0.15dB MAX. (300 KHz to 2.5 GHz) 0.20dB MAX. (2.5 GHz to 6.0 GHz) 0.40dB MAX. (6.0 GHz to 11.0 GHz)

5.2 Electrical Performance

6. Isolation	
Reference standard:	-
Test conditions:	Measure the isolation as shown in Fig. 4 by the network analyzer. Frequency : 300KHz to 11GHz
Fig. 4 Off state Isolation	
Pass criteria:	[Off state] 20dB MIN. (300kHz to 3.0GHz) 15dB MIN. (3.0GHz to 6.0GHz) 12dB MIN. (6.0GHz to 11.0GHz)

5.3 Mechanical Performance**1. Durability**

Reference standard:	-
Test conditions:	Repeat mating and un-mating 100 cycles at along the mating axis.
Pass criteria:	[Contact Resistance] Shall meet 5.2.1 [Appearance] No abnormality adversely affecting the performance shall occur.

2. Vibration

Reference standard:	-
Test conditions:	Apply the following vibration to the mating connector. During the testing, run 100mA DC to check electrical discontinuity. Frequency: 10Hz → 55Hz → 10Hz / Approx. 1 minutes. Half amplitude, Peak value of acceleration: 0.75mm or 98m/s ² (10G) Directions, Cycling: 3 mutually perpendicular direction, 10 cycles for each direction.
Pass criteria:	[Contact Resistance] Shall meet 5.2.1 [Electrical Discontinuity] 1μs MAX. [Appearance] No abnormality adversely affecting the performance shall occur.

3. Shock

Reference standard:	MIL-STD-202-213, Test condition B.
Test conditions:	Apply the following shock to the mating switch. During the testing, run 100mA DC to check electrical discontinuity. Peak value of acceleration: 490m/s ² (50G) Duration: 11msec. Wave Form: Half sinusoidal Direction, Cycle: 3 mutually perpendicular direction, 3 cycles for each direction
Pass criteria:	[Contact Resistance] Shall meet 5.2.1 [Electrical Discontinuity] 1μs MAX. [Appearance] No abnormality adversely affecting the performance shall occur.

5.4 Environmental Performance**1. Humidity (Steady state)**

Reference standard: MIL-STD-202-103, Test condition B.

Test conditions: Apply the following environment to the switch.
Temperature: $33\pm 2^{\circ}\text{K}$ ($60\pm 2^{\circ}\text{C}$)
Humidity: 90 to 95%RH
Duration: 96 hoursPass criteria: [Contact Resistance] Shall meet 5.2.1.
[Insulation Resistance] Shall meet 5.2.2.
[Appearance] No abnormality adversely affecting the performance shall occur.**2. Thermal shock**

Reference standard: MIL-STD-202-107, Test condition A.

Test conditions: Apply the following environment to the switch.
Temperature: 218K (-55°C) :30 minutes \leftrightarrow 358K (85°C) :30 minutes
Transition time: 5 minutes
Number of cycles: 100 cyclesPass criteria: [Contact Resistance] Shall meet 5.2.1.
[Insulation Resistance] Shall meet 5.2.2.
[Appearance] No abnormality adversely affecting the performance shall occur.**3. Dry Heat**

Reference standard: MIL-STD-202-213, Test condition A.

Test conditions: Apply the following environment to the switch.
Temperature: $358\pm 2^{\circ}\text{K}$ ($85\pm 2^{\circ}\text{C}$)
Duration: 96 hoursPass criteria: [Contact Resistance] Shall meet 5.2.1.
[Insulation Resistance] Shall meet 5.2.2.
[Appearance] No abnormality adversely affecting the performance shall occur.

5.4 Environmental Performance

4. Cold	
Reference standard:	MIL-STD-202-107, Test condition A.
Test conditions:	Apply the following environment to the switch. Temperature: 218±2K (-55±2°C) Duration: 96 hours
Pass criteria:	[Contact Resistance] Shall meet 5.2.1. [Insulation Resistance] Shall meet 5.2.2. [Appearance] No abnormality adversely affecting the performance shall occur.

5. Saltwater spray	
Reference standard:	-
Test conditions:	Apply the following environment to the switch. Temperature: 308±2K (35±2°C) Salt water density: 5±1% [by weight] Duration: 72 hours
Pass criteria:	[Appearance] No abnormality adversely affecting the performance shall occur.

5.5 Others

1. Soldering heat resistance

Reference standard: -

Test conditions: Apply the following environment to the switch.
Reflow condition: Refer to Fig. 5.

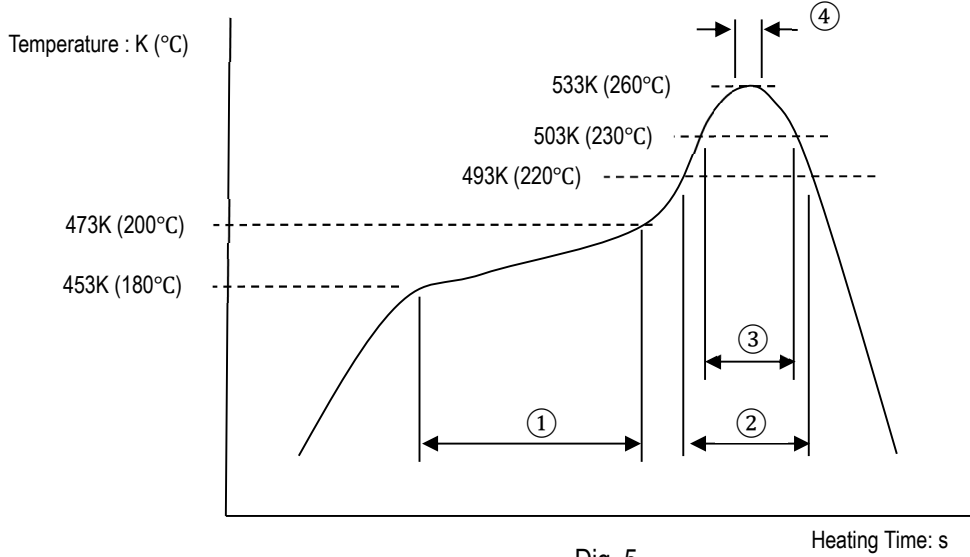

Dig. 5

Table 2

① Pre Heating Zone 453K(180°C) – 473K(200°C)	60 – 120 sec.
② Soldering Zone 493K(220°C) min.	60 – 150 sec.
③ Soldering Zone 503K(230°C) min.	40 sec. max.
④ Peak 533K(260°C)	10 sec. max.
Heating Method	Infrared
Reflow cycles	cycles max.

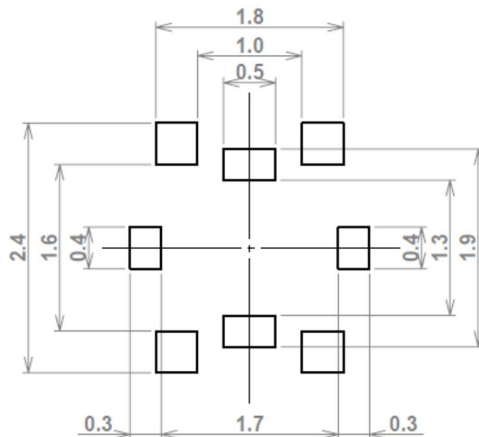

Tolerance	±0.05
Thickness	0.1
Unit	mm

Fig. 6 Metal mask dimensions

Pass criteria: No abnormality adversely affecting the performance shall not occur.

6. Test Sequence and Specimen Quantity

Details of the Testing Groups A to K are indicated in test report.

Table.3 Test Sequence and Sample Quantity

No.	Test Item	Testing Groups										
		A	B	C	D	E	F	G	H	J	K	
5.2 Electrical Performance	1	Contact resistance			1,3	1,3,5	1,3	1,3	1,3	1,3		
	2	Insulation resistance	1				4	4	4	4		
	3	Dielectric withstanding voltage	2									
	4	VSWR		1								
	5	Insertion Loss		2								
	6	Isolation		3								
5.3 Mechanical Performance	1	Durability			2							
	2	Vibration				2						
	3	Shock				4						
5.4 Environmental Performance	1	Humidity (Steady State)					2					
	2	Thermal shock						2				
	3	Dry Heat							2			
	4	Cold								2		
	5	Saltwater spray									1	
5.5 Others	1	Soldering heat resistance										1
Specimen quantity			5	5	5	5	5	5	5	5	5	5

※Numbers indicate test sequences.