

ISH[®] CONNECTOR ISH[®] V CONNECTOR ISH[®] VS CONNECTOR

Product Specification

Qualification Test Report No. STR-23004

| | | | | | |
|------|--------|---------------|--------------|-------------|-------------|
| | | | | | |
| | | | | | |
| | | | | | |
| 0 | RS0942 | June 14, 2023 | Y. Nishimura | J. Mukunoki | J. Tateishi |
| Rev. | ECN | Date | Prepared by | Checked by | Approved by |

1. Scope : This CONNECTOR is a 0.5mm terminal miniature SMT connector.
2. Purpose : This specification is compliant with LV214.
It covers the requirements for product performance and test methods of ISH CONNECTOR.
3. Application items
This specification is applicable to the items listed below

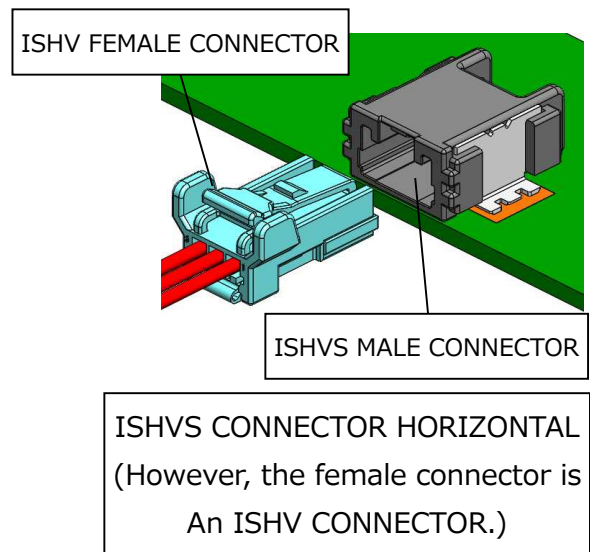
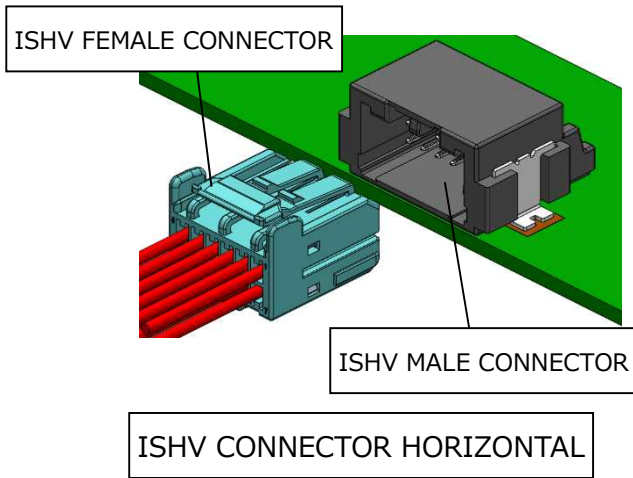
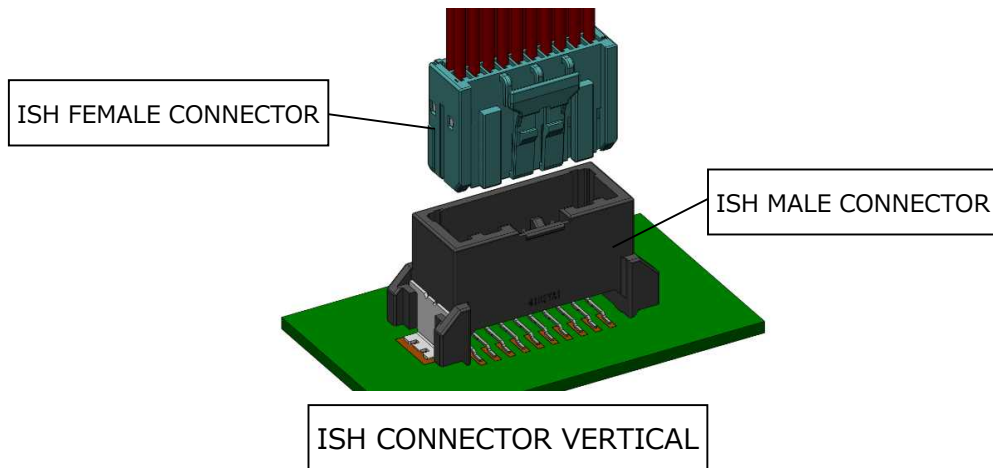

Table 1. Product line

| TYPE | Plating | No of poles | PARTS No. | | | |
|----------------------------|---------|-------------|----------------|-----------------|-----------------|----------------------|
| | | | MALE ASSY | FEMALE HOUSING | RETAINER | FEMALE TERMINAL |
| ISH CONNECTOR VERTICAL | Sn | 8P | V0026-008E-00* | V0027-91008-211 | V0116-92008-01 | VT009-01 VT009-02 |
| | | 10p | V0019-010E-00* | V0020-91010-211 | V0020-92010-211 | |
| | | 20P | V0019-020E-00* | V0020-91020-211 | V0020-92020-211 | |
| | | 26P | V0019-026E-00* | V0020-91026-211 | V0020-92026-211 | |
| ISHV CONNECTOR HORIZONTAL | Sn | 12P | V0025-012E-001 | V0027-91012-211 | V0027-92012-211 | VT009-01 VT009-02 |
| | | 16P | V0025-016E-001 | V0027-91016-211 | V0027-92016-211 | |
| ISHVS CONNECTOR HORIZONTAL | Au | 3P | V0085-003E-001 | V0037-91003-211 | - | VT009-03 |

4. Operating Condition

Temperature Sn : -40~125°C (including temperature rise)

Au : -40~150°C (including temperature rise)

5. Construction, Materials and Finish

5.1 ISH CONNECTOR, ISHV CONNECTOR

(1) MALE HOUSING Material : Glass-filled LCP, Flame retardance : UL94V-0, Color : BLACK

(2) MALE TERMINAL Material : BRASS, Plating : Sn(Reflow)

(3) PEG Material : BRASS, Plating : Sn(Reflow)

(4) FEMALE HOUSING Material : PBT, Flame retardance : UL94HB, Color : BLACK

(5) FEMALE RETAINER Material : PBT, Flame retardance : UL94HB, Color : BLACK

(6) FEMALE TERMINAL BOX Material : BRASS, Plating : Sn(Reflow)

Spring Material : Copper alloy, Plating : Sn(Reflow)

(7) Applicable Cable Cross section : 0.3mm²、0.5mm²

Outer diameter : 1.60mm MAX.

5.2 ISHVS CONNECTOR

(1) MALE HOUSING Material : Glass-filled LCP, Flame retardance : UL94V-0, Color : BLACK

(2) MALE TERMINAL Material : BRASS

Plating Contact area : Au

Soldering area : Sn(Reflow)

(3) PEG Material : BRASS, Plating : Sn(Reflow)

(4) FEMALE HOUSING Material : PBT, Flame retardance : UL94HB, Color : BLACK

(5) FEMALE TERMINAL BOX Material : BRASS,

Plating Contact are : Au, Crimping area : Sn(Reflow)

Spring Material : Copper alloy, Plating : Au

(6) Applicable Cable Cross section : 0.3mm²、0.5mm²

Outer diameter : 1.60mm MAX.

5.3 Terminal crimp specification

Terminal crimp specification compliant with Handling Manual 【HDM-0020】

6. Reflow Temperature Profile

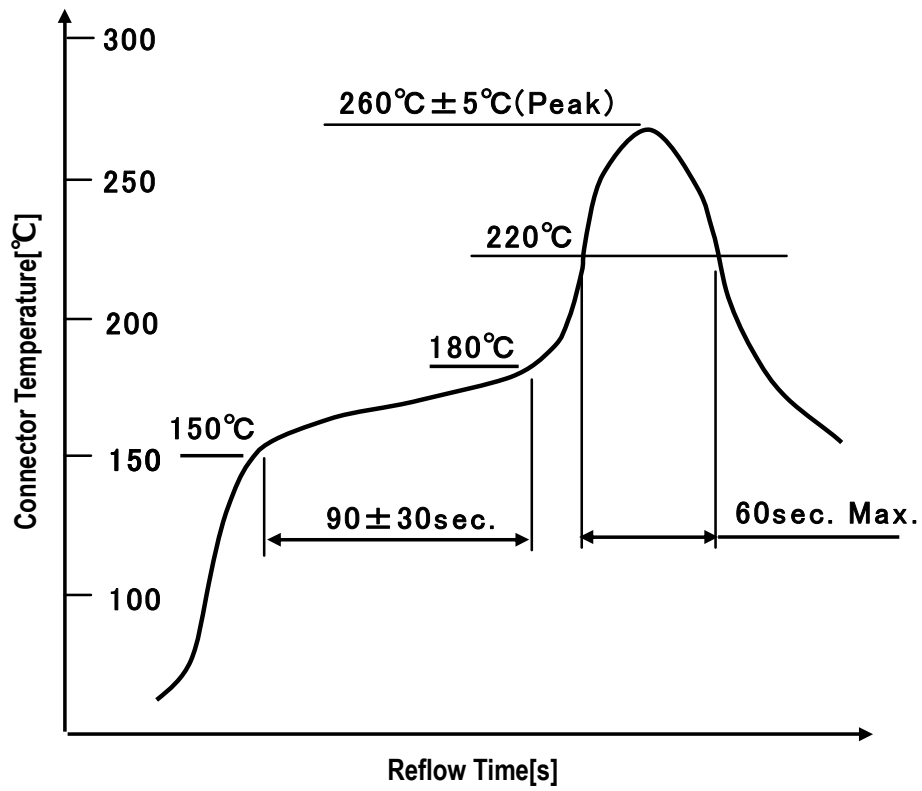

Fig 1.Reflow profile

※Use Metal Mask which has a thickness of 0.15mm MIN. when the male connector is mounted on the PCB.

7. Test Methods and Performances

7.1 Mechanical Performances

Table 2. Mechanical Performances

| LV214 | PPS-0011 No. | Test item |
|--------|--------------|--|
| PG 0 | 7.2 | Inspection of as-received condition |
| PG 1 | 7.4 | Dimensions |
| PG 2 | 7.5 | Material and surface analysis, contacts |
| PG 3 | 7.6 | Material and surface analysis, housing |
| PG 4 | 7.7 | Contact engagement length |
| PG 5 | 7.8 | Mechanical and thermal relaxation behavior |
| PG 6 | 7.9 | Interaction between contact and housing |
| PG 7 | 7.10 | Handling and functional reliability of the housing |
| PG 8 | 7.11 | Insertion and retention forces of the contact parts in the housing |
| PG 9 | 7.12 | Insertion inclination/misuse safe(scoop-proofing) |
| PG 10 | 7.13 | Contacts : conductor pull-out strength |
| PG 11 | 7.14 | Contacts : Insertion and removal forces, mating cycle frequency |
| PG 12 | 7.15 | Current heating, derating |
| PG 13 | 7.16 | Housing influence on the derating |
| PG 14 | 7.17 | thermal time constant(current excess temperature at n times rated current) |
| PG 15 | 7.18 | Electrical stress test |
| PG 16 | 7.19 | Friction corrosion |
| PG 17 | 7.20 | Dynamic load |
| PG 19 | 7.21 | Environmental |
| PG 20 | 7.22 | Climate load of the housing |
| PG 21 | 7.23 | Long-term temperature aging |
| PG 22A | 7.24 | Chemical resistance |
| PG 28 | 7.25 | Locking noise |

7.2 Electrical Performances Test Method [LV214 E0.2,E14.0]

(1) Dry Circuit Resistance [LV214 E0.2]

A. Test method •••Apply current at 20mV (open circuit), 10mA (short circuit).

Measure and record the resistance across A to B and B to C as illustrated in Figure 1, In-Line Circuit Test Lead Location.

Calculate the resistance with the following formula: $R = R_{(AC)} = R_{(AB)} - R_{(BC)}$

※ $R_{(BC)}$: Cable conductor resistance

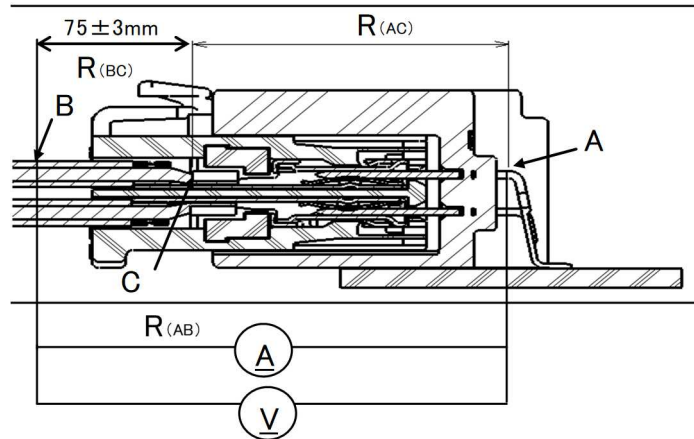

Fig 2. In-line Circuit Test Lead Location

B. Requirement •••Initial : 10mΩ Max. After test : 20mΩ Min.

(2) Continuous contact resistance [LV214 E14.0]

A. Test method •••Monitor voltage drop during the test.

B. requirement •••Record must be maintained.

7.3 Inspection of as-received condition [LV214 PG 0]

(1) Visual inspection [E 0.1]

Number of test sample •••Each part n=5

A. Test method •••Visual (e.g. magnifier) and tactile verification.

B. requirement •••No detrimental deformation.

(2) Dry circuit resistance [E 0.2]

Number of test sample • • • Connector n=5

A. Test method • • • See 7.2(1)

① Contact resistance in contact area ② Contact resistance in line area will be measured.

B. requirement • • • See 7.2(1)

(3) Insulation resistance [E 0.3]

Number of test sample • • • Mated connector n=5

A. Test method • • • Measure insulation resistance between all adjacent contacts.

Test Voltage=500+50V, test time=60±5s

B. requirement • • • 100MΩ Min.

7.4 Dimensions [LV214 PG 1]

Number of test sample • • • Each part n=1

(1) Visual inspection [E 0.1]

A. Test method • • • Visual (e.g. magnifier) and tactile verification.

B. requirement • • • No detrimental deformation.

(2) Dimensions [E 1.1]

A. Test method • • • Measure dimensions using caliper, micrometer, projector.

B. requirement • • • Satisfy drawing dimension.

(3) Dimensions (of processed components) [E 1.2]

A. Test method • • • Measure dimensions of the crimping part using caliper, micrometer, projector.

B. requirement • • • Satisfy drawing dimension.

7.5 Material and surface analysis, contacts [LV214 PG 2]

Number of test sample • • • Male terminal, Female terminal, Peg n=1

(1) Visual inspection [E 0.1]

A. Test method • • • Visual (e.g. magnifier) and tactile verification.

B. requirement • • • No detrimental deformation.

(2) Material test of contact parts [E 2.1]

A. Test method • • • Material properties indication for male terminal, female terminal and peg.

Material: material certificate, conductivity, tensile strength, modulus of elasticity

B. requirement • • • Record must be maintained. RoHS, ELV directives must be observed.

7.6 Material and surface analysis, housings and single-wire seals [LV214 PG 3]

Number of test sample • • • Male housing, Female housing, Retainer n=1

(1) Visual inspection [E 0.1]

A. Test method • • • Visual (e.g. magnifier) and tactile verification.

B. requirement • • • No detrimental deformation.

(2) Material test of housings and single-wire seals [E 3.1]

A. Test method • • • Material properties indication for male terminal, female terminal and peg.

① Material: Material certificate

② Measurement of burrs in functional areas

B. requirement • • • Record must be maintained. No burrs detrimental to function.

(3) Markings on the surface [E 3.2]

A. Test method • • • Check for any dirt or markings on assembled parts, male housing, female housing and retainer.

B. requirement • • • Must satisfy appearance inspection of the inspection standard.

No burrs on functional area.

7.7 Contact engagement length [LV214 PG 4]

Number of test sample •••Confirmed by the CAD

(1) Contact engagement length [E 4.1]

A. Test method •••Contact engagement length and required clearance must be calculated based on worst case dimensions.

B. requirement •••Contact engagement length : >1.00mm (for all contact points)

Clearance : >0.00mm (in the worst case)

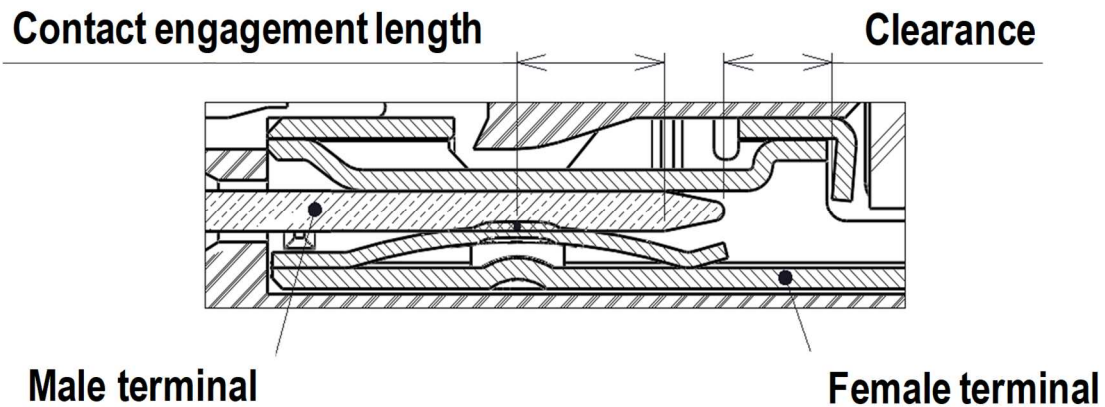

Fig 3. Contact engagement length, Clearance

7.8 Mechanical and thermal relaxation behavior [LV214 PG 5]

Number of test sample •••Male terminal, Female terminal n=5 (Group1 to 6)

(1) Visual inspection [E 0.1]

A. Test method •••Visual(e.g. magnifier) and tactile verification. (All groups)

B. requirement •••No detrimental deformation.

(2) Contact opening dimension in the unused condition (optical measurement) [E 5.1]

A. Test method •••Measure contact opening dimension. (All groups)

B. requirement •••Record the measured values.

(3) Insertion and removal before the test (5 times) [B 5.1]

A. Test method •••Insert and remove the terminal 5 times. (All groups)

(4) Contact opening dimension of the inserted 5 times (optical measurement) [E 5.1]

A. Test method • • • Measure contact opening dimension. (All groups)

B. requirement • • • Record the measured values.

(5) Normal contact force [E 5.2]

A. Test method • • • Measure normal contact force. (Group 1)

B. requirement • • • Record measurement method and measured values.

(6) Insert test sample [B 5.2]

A. Test method • • • Insert male terminal into female terminal. (Group 2 to 6)

(7) Aging in dry heat, inserted [B 5.3]

A. Test method • • • Age mated samples in chamber at 125°C. Remove the sample at each specified timing (1h, 100h, 200h, 500h, and 1000h). (Group 2 to 6)

(8) Visual inspection [E 0.1]

A. Test method • • • Visual (e.g. magnifier) and tactile verification. (Group 2 to 6)

B. requirement • • • No detrimental deformation.

(9) Contact opening dimension [E 5.1]

A. Test method • • • Measure contact opening dimension. (Group 2 to 6)

B. requirement • • • Record the measured values.

(10) Normal contact force [E 5.2]

A. Test method • • • Measure normal contact force. (Group 2 to 6)

B. requirement • • • Record measurement method and measured values.

7.9 Interaction between contact and housing [LV214 PG 6]

Number of test sample • • • Female housing, Female terminal, Female connector (before secondary lock) n=5

(1) Visual inspection [E 0.1]

A. Test method • • • Visual (e.g. magnifier) and tactile verification.

B. requirement • • • No detrimental deformation.

(2) Actuation forces for primary lock [E 6.2]

A. Test method • • • Insert terminal completely into housing, pull out at 10N max.

B. requirement • • • Confirm audible click for primary lock.

Confirm that it is locked under tensile strength (10N max.).

(3) Actuation forces for secondary lock [E 6.4]

A. Test method • • • Fully populate the female connector housing, insert the retainer then remove.

B. requirement • • • ① Force when secondary lock is locked: 50N max.

② Force when unlocked: 10N to 50N

③ Insertion is not possible unless terminals are in the correct position

7.10 Handling and functional reliability of the housing [LV214 PG 7]

Number of test sample • • • Male connector, Female housing n=5

(1) Visual inspection [E 0.1]

A. Test method • • • Visual (e.g. magnifier) and tactile verification.

B. requirement • • • No detrimental deformation.

(2) Retention force of the housing latch/lock [E 7.2]

A. Test method • • • Measure the force required to pull the female housing by a distance of 1mm, and the maximum force. Female housing is mated without any terminals and locked.

If female housing has CPA, test must be performed for both CPA open and closed.

B. requirement • • • 3P: 50N Min.

8P or more: 60N Min.

(3) Visual inspection [E 0.1]

A. Test method • • • Visual (e.g. magnifier) and tactile verification.

B. requirement • • • No detrimental deformation.

7.11 Insertion and retention forces of the contact parts in the housing [LV214 PG 8]

Number of test sample • • • Female connector, Female terminal n=3(Terminal n=10 Min.)

(1) Visual inspection [E 0.1]

A. Test method • • • Visual(e.g. magnifier) and tactile verification.

B. requirement • • • No detrimental deformation.

(2) Determination of the contact insertion forces [E 8.1]

A. Test method • • • Determine the peak force required to insert female terminal into housing.

B. requirement • • • 15N Max.

(3) Contact removal force from the housing [E 8.2]

A. Test method • • • Measure the force required to remove the terminal from the housing, by pulling female terminal into the opposite direction of insertion.

There are two types of locking: primary locking only and secondary locking included.

B. requirement • • • primary lock : 30N Min.

secondary lock : 60N Min.

(4) Visual inspection [E 0.1]

A. Test method • • • Visual(e.g. magnifier) and tactile verification.

B. requirement • • • No detrimental deformation.

7.12 Insertion inclination/misuse safe(scoop-proofing) [LV214 PG 9]

Number of test sample • • • Confirmed by the CAD

(1) Max. possible insertion inclination [E 9.2]

A. Test method • • • Using CAD, verify mated state under maximum possible insertion inclination (X and Y directions. Z is the insertion direction).

B. requirement • • • Must be designed so connector is guided into housing without female terminal settling or male terminal buckling under the worst case dimensions.

(2) Examination of housing for scoop-proofing [E 9.3]

A. Test method • • • Using CAD, verify scoop-proofing.

B. requirement • • • Electrical connection is established only when correctly mated.

No interference between male terminal and female housing.

7.13 Contacts : conductor pull-out strength [LV214 PG 10]

Number of test sample • • • Female terminal n=10

(1) Visual inspection [E 0.1]

A. Test method • • • Visual(e.g. magnifier) and tactile verification.

B. requirement • • • No detrimental deformation.

(2) conductor pull-out strength [E 10.1]

A. Test method • • • Measure the force required to pull out the conductor from the crimp.

Insulation barrel is not in function.

B. requirement • • • 50N Min.(Conductor : 0.3sq(AWG22))

7.14 Contacts : Insertion and removal forces, mating cycle frequency [LV214 PG 11]

Number of test sample • • • Male connector, Female connector n=5

(1) Visual inspection [E 0.1]

A. Test method • • • Visual(e.g. magnifier) and tactile verification.

B. requirement • • • No detrimental deformation.

(2) Contacts : Insertion and removal forces, mating cycle frequency [E 11.1]

A. Test method • • • Depending on the plating type, repeat insertion/removal as follows.

No addition of lubricant.

Sn:20 times Au:100 times

B. requirement • • • ① Insertion force change compared with the initial value must be 25% max.

② No scraping of contact plating.

7.15 Current heating, derating [LV214 PG12]

Number of test sample • • • Male terminal, Female terminal n=5

Female terminal cable size and length : 0.3sq(AWG22), 200mm .

(1) Visual inspection [E 0.1]

A. Test method • • • Visual(e.g. magnifier) and tactile verification.

B. requirement • • • No detrimental deformation.

(2) Current excess temperature without housing [E 12.1]

A. Test method • • • Apply current value the 4.5A to single terminal.

(temperature change of terminal must be $\pm 2^{\circ}\text{C}$ min. when measured for 3 times at an interval of 5 minutes) Leave the terminal for 1 hour to stabilize temperature and measure the increase.

B. requirement • • • Temperature increase of each terminal size must be 30°C max.

(3) Derating without housing [E 12.2]

A. Test method • • • Different current is applied to DC circuit and left for 1 h to stabilize the terminal temperature.

(temperature change of terminal must be $\pm 2^{\circ}\text{C}$ min. when measured for 3 times at an interval of 5 minutes)

Measure the ambient temperature at a distance of 50mm min. horizontally from the sample.

Record the ambient temperature, surface temperature of the terminal, and current applied.

Create base curve and 80% derating curve from the temperature increase curve.

B. requirement • • • Create derating curve.

(4) Visual inspection [E 0.1]

A. Test method • • • Visual (e.g. magnifier) and tactile verification.

B. requirement • • • No detrimental deformation.

7.16 Housing influence on the derating [LV214 PG13]

Number of test sample • • • Mated connector n=5

Female terminal cable size and length : 0.3sq(AWG22), 200mm .

(1) Visual inspection [E 0.1]

A. Test method • • • Visual(e.g. magnifier) and tactile verification.

B. requirement • • • No detrimental deformation.

(2) Current excess temperature with housing [E 13.1]

A. Test method • • • Apply the rated current in Table 3 to all terminals.

(temperature change of terminal must be $\pm 2^{\circ}\text{C}$ min. when measured for 3 times at an interval of 5 minutes) Leave the terminal for 1 hour to stabilize temperature and measure the increase.

B. requirement • • • Temperature increase of each terminal size must be 30°C max.

Table 3. Number of poles by current value

| No of Poles | Current value[A] | No of Poles | Current value[A] |
|-------------|------------------|-------------|------------------|
| 3 | 3.0 | 16 | 1.8 |
| 6 | 2.7 | 20 | 1.4 |
| 8 | 2.6 | 24 | 1.0 |
| 10 | 2.4 | 26 | 0.8 |
| 12 | 2.2 | 28 | 0.6 |

(3) Derating with housing [E 13.2]

A. Test method • • • Different current is applied to DC circuit and left for 1 h to stabilize the terminal temperature.

(temperature change of terminal must be $\pm 2^{\circ}\text{C}$ min. when measured for 3 times at an interval of 5 minutes)

Measure the ambient temperature at a distance of 50mm min. horizontally from the sample.

Record the ambient temperature, surface temperature of the terminal, and current applied.

Create base curve and 80% derating curve from the temperature increase curve.

B. requirement • • • Create derating curve.

(4) Visual inspection [E 0.1]

A. Test method • • • Visual(e.g. magnifier) and tactile verification.

B. requirement • • • No detrimental deformation.

7.17 Thermal time constant (current excess temperature at n times rated current) [LV214 PG 14]

Number of test sample • • • Male terminal, Female terminal n=3

(1) Visual inspection [E 0.1]

A. Test method • • • Visual (e.g. magnifier) and tactile verification.

B. requirement • • • No detrimental deformation.

(2) Thermal time constant [E 14.1]

A. Test method • • • Apply current value of 1x, 2x, 3x, 4x, 5x the 4.5A to single terminal.

(temperature change of terminal must be $\pm 2^{\circ}\text{C}/\text{min}$. when measured for 3 times at an interval of 5 minutes) Leave the terminal for 1 hour to stabilize temperature and measure the increase. Temperature increase tolerance: 100°C

B. requirement • • • Create temperature increase graph.

(3) Visual inspection [E 0.1]

A. Test method • • • Visual (e.g. magnifier) and tactile verification.

B. requirement • • • No detrimental deformation.

7.18 Electrical stress test [LV214 PG 15]

Number of test sample • • • Connector n=5

(1) Visual inspection [E 0.1]

A. Test method • • • Visual (e.g. magnifier) and tactile verification.

B. requirement • • • No detrimental deformation.

(2) Contact opening dimension [E5.1]

A. Test method • • • Insert and remove male terminal and female terminal twice, then measure the contact opening dimension.

B. requirement • • • Record measured values.

(3) Dry circuit resistance [E 0.2]

A. Test method • • • See 7.2(1)

B. requirement • • • See 7.2(1)

(4) Derating [E 12.2]

- A. Test method ••• Different current is applied to DC circuit and left for 1 h to stabilize the terminal temperature.
 (temperature change of terminal must be $\pm 2^{\circ}\text{C}$ min. when measured for 3 times at an interval of 5 minutes)
 Measure the ambient temperature at a distance of 50mm min. horizontally from the sample.
 Record the ambient temperature, surface temperature of the terminal, and current applied.
 Create base curve and 80% derating curve from the temperature increase curve.
 Limit temperature of derating graph : 125°C

- B. requirement ••• Create derating curve.

(5) Continuous contact resistance during (6) with test current [E 14.0]

- A. Test method ••• See 7.2(2)
 Continuous contact resistance during (6) with test current
 Frequency of measurement: every 5 minutes

- B. requirement ••• See 7.2(2)

(6) Temperature cycle endurance test/current cycle endurance test [B 15.2]

- A. Test method ••• Apply current so the temperature increase is 45°C . $T_0=80^{\circ}\text{C}$.
 1 cycle (6h) as shown in Fig. 4. Repeat 60 cycles.

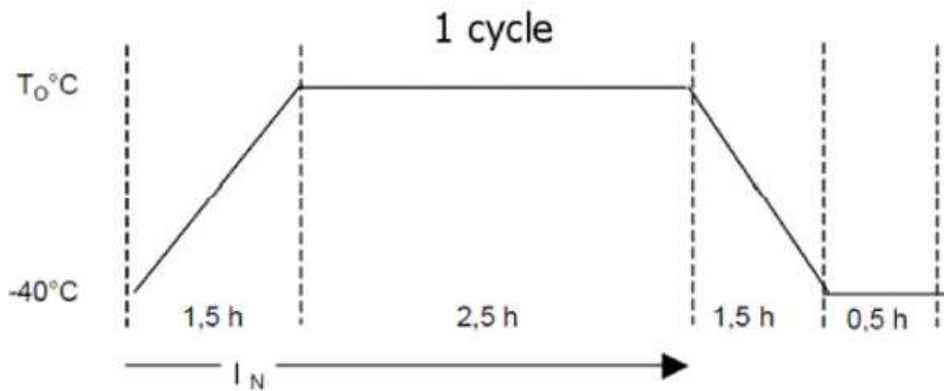

Fig 4. Temperature cycle

(7) Humid heat, cycle [B 15.3]

A. Test method ••• Temperature: 25~55°C. Relative humidity: 95%RH.

1 cycle (24h) as shown in Fig. 5. Repeat 21 cycles.

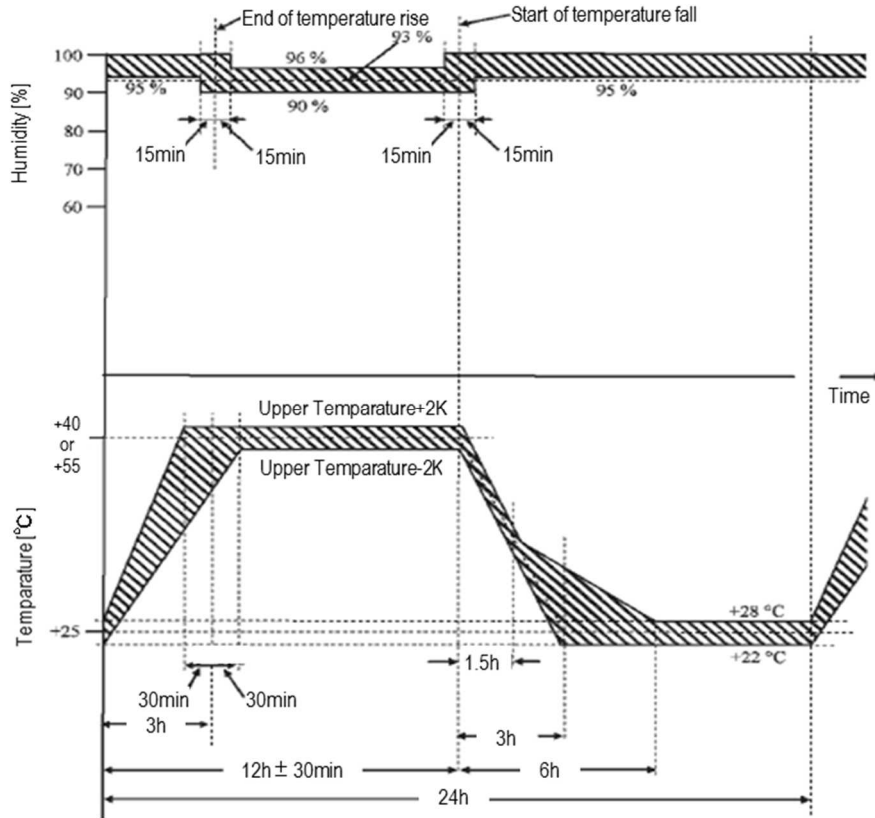

Fig 5. Humid heat cycle

(8) Continuous contact resistance during (9) with test current [E 14.0]

A. Test method ••• See 7.2(2)

Continuous contact resistance during (9) with test current

Frequency of measurement: every 5 minutes

B. requirement ••• See 7.2(2)

(9) Temperature cycle endurance test/current cycle endurance test [B 15.2]

A. Test method ••• Apply current so the temperature increase is 18°C. T₀=62°C.

1 cycle (6h) as shown in Fig. 4. Repeat 60 cycles.

(10) Dry circuit resistance [E 0.2]

A. Test method ••• See 7.2(1)

B. requirement ••• See 7.2(1)

(11) Contact opening dimension [E 5.1]

A. Test method • • • Measure contact opening dimension

B. requirement • • • Record the measured values.

(12) Visual inspection [E 0.1]

A. Test method • • • Visual(e.g. magnifier) and tactile verification.

B. requirement • • • No detrimental deformation.

7.19 Friction corrosion [LV214 PG 16]

Number of test sample • • • Male terminal, Female terminal n=5

(1) Visual inspection [E 0.1]

A. Test method • • • Visual(e.g. magnifier) and tactile verification.

B. requirement • • • No detrimental deformation.

(2) Contact resistance, continuous monitoring during (3), recording, and storing [E 16.0]

A. Test method • • • See 7.2(2)

Continuous contact resistance during (3) with test current

Frequency: 4Hz

B. requirement • • • See 7.2(2)

(3) Friction load [B 16.1]

A. Test method • • • Insert male terminal into female terminal. Distance of fretting motion: 50µm,

Cycle time : 1Hz、 No. of cycles: 10000 cycles min.. Monitor dry circuit resistance during fretting motion MAX.100mV、 10mA

B. requirement • • • Create a graph of resistance vs no. of cycles.

Record cycles at dry circuit resistance 300mΩ.

(4) Visual inspection [E 0.1]

A. Test method • • • Visual(e.g. magnifier) and tactile verification.

B. requirement • • • No detrimental deformation.

7.20 Dynamic load [LV214 PG 17]

Number of test sample • • • Male terminal, Female terminal n=10(Connector n=2 Min.)

(1) Visual inspection [E 0.1]

A. Test method • • • Visual(e.g. magnifier) and tactile verification.

B. requirement • • • No detrimental deformation.

(2) Dry circuit resistance [E 0.2]

A. Test method • • • See 7.2(1)

B. requirement • • • See 7.2(1)

(3) Continuous contact resistance during (4) with test current [E 14.0]

A. Test method • • • See 7.2(2)

Continuous contact resistance during (4) with test current (100 mA)

Frequency of measurement: every 1 minute

B. requirement • • • See 7.2(2)

(4) Dynamic load, broad-band random vibration [B 17.2]

A. Test method • • • Vibration: see Table 6

Sweep speed: 1 oct./min

Table 4. Vibration and shock (Body, non-sealed)

| TC (temp. cycle) | Random vibration with TC | | Sine wave with TC | No. of shocks |
|-------------------|---|--------------------------------------|-------------------|--|
| | 8 h per axis RMS value of acceleration 19.7m/s ² | | | |
| 0 min / 20 °C | Hz | (m/s ²) ² /Hz | No sine wave | A=30 G T=6 ms Sinusoidal half-wave No. of shocks : 6000 |
| 60 min / - 40 °C | 10 | 10 | | |
| 150 min / - 40 °C | 55 | 3.25 | | |
| 300 min / 105 °C | 180 | 0.125 | | |
| 420 min / 105 °C | 300 | 0.125 | | |
| 480 min / 20 °C | 360 | 0.07 | | |
| | 1000 | 0.07 | | |

(5) Visual inspection [E 0.1]

A. Test method • • • Visual (e.g. magnifier) and tactile verification.

B. requirement • • • No detrimental deformation.

(6) Continuous contact resistance during (7) with test current [E 14.0]

A. Test method • • • See 7.2(2)

Continuous contact resistance during (7) with test current (100 mA)

Frequency of measurement: every 1 minute

B. requirement • • • See 7.2(2)

(7) Endurance shock test [B 17.3]

A. Test method • • • Vibration: see Table 6

Sweep speed: 1 oct./min

(8) Visual inspection [E 0.1]

A. Test method • • • Visual (e.g. magnifier) and tactile verification.

B. requirement • • • No detrimental deformation.

(9) Dry circuit resistance [E 0.2]

A. Test method • • • See 7.2(1)

B. requirement • • • See 7.2(1)

(10) Resonance frequency of the contact assembly [B 17.4]

A. Test method • • • Affix vibration transducer to the housing to determine resonance frequency, based on the conditions below:

Dynamic load, sinusoidal

Sweep speed: $a = 10 \text{ m/s}^2$

$f = 5 \text{ Hz} - 2\,000 \text{ Hz} - 5 \text{ Hz}$

B. requirement • • • Create a graph of vibration response of the housing.

7.21 Environmental simulation [LV214 PG19]

Number of test sample...Connector n=5(Group1 to 3)

Table 5. Description of the 3 groups

| | Group 1 | Group 2 | Group 3 |
|---------------------------|----------------|-----------------|--------------------------------|
| No. of samples | 10 | 10 | 10 |
| No. of insertion | Once | Once | Sn : 10 times Au : 50 times |
| Inserted/ Not inserted | Not inserted | Inserted | Inserted |
| Measurement Method | 7.2(1) [E 0.2] | 7.2(2) [E 14.0] | 7.2(2) [E 14.0] |

(1) Visual inspection [E 0.1]

A. Test method...Visual (e.g. magnifier) and tactile verification. (All groups)

B. requirement...No detrimental deformation.

(2) Dry circuit resistance [E 0.2]

A. Test method...See 7.2(1). (All groups)

B. requirement...See 7.2(1)

(3) Inserting and removing [B 19.0]

A. Test method...Insert/remove connectors for each group according to Table 7.

(4) Dry circuit resistance [E 0.2]

A. Test method...See 7.2(1). (All groups)

B. requirement...See 7.2(1)

(5) Continuous contact resistance during (6) with test current [E 14.0]

A. Test method...See 7.2(2)

Continuous contact resistance during (6) with test current (100 mA)

Frequency of measurement: every 1 minute (Groups 2 and 3)

B. requirement...See 7.2(2)

(6) Temperature shock [B 19.1]

A. Test method . . . —40°C ⇔ 125°C. 1 cycle=15 mins. Repeat 144 cycles.

Acclimatization period: 10 sec. max. (All groups)

(7) Continuous contact resistance during (8) with test current [E 14.0]

A. Test method . . . See 7.2(2)

Continuous contact resistance during (8) with test current (100 mA)

Frequency of measurement: every 5 minute (Groups 2 and 3)

B. requirement . . . See 7.2(2)

(8) Temperature cycle [B 19.2]

A. Test method . . . —40°C ⇔ 125°C. 1 cycle= 10 h (with 3 h. time for temperature cycle: 2 h max.) Repeat 20 cycles. (All groups)

(9) Continuous contact resistance during (10) with test current [E 14.0]

A. Test method . . . See 7.2(2)

Continuous contact resistance during (10) with test current (100 mA)

Frequency of measurement: every 5 minute (Groups 2 and 3)

B. requirement . . . See 7.2(2)

(10) Aging in dry heat [B 19.3]

A. Test method . . . Age for 120 h in chamber at 125°C. (All groups)

(11) Visual inspection [E 0.1]

A. Test method . . . Visual (e.g. magnifier) and tactile verification. (All groups)

B. requirement . . . No detrimental deformation.

(12) Industrial climate (multi-component climate)[B 19.4]

A. Test method . . . Age for 21 days in the chamber. Temperature 25°C. Relative humidity: 75%. Flow rate: 1m³/h.

SO₂: 0.2ppm, H₂S: 0.01ppm, NO₂: 0.2ppm, Cl₂: 0.01ppm

(13) Continuous contact resistance during (14) with test current [E 14.0]

A. Test method . . . See 7.2(2)

Continuous contact resistance during (14) with test current (100 mA)

Frequency of measurement: every 10 minutes (Groups 2 and 3)

B. requirement . . . See 7.2(2)

(14) Humid heat, cyclic [B 19.5]

- A. Test method ••• Temperature: 25~55°C. Relative humidity: 95%RH.
1 cycle (24h) as shown in Fig. 4. Repeat 10 cycles. (All groups)

(15) Visual inspection [E 0.1]

- A. Test method ••• Visual(e.g. magnifier) and tactile verification.
- B. requirement ••• No detrimental deformation.

(16) Continuous contact resistance during (17) with test current [E 14.0]

- A. Test method ••• See 7.2(2)
Continuous contact resistance during (17) with test current (100 mA)
Frequency of measurement: every 10 minutes (Groups 2 and 3)
- B. requirement ••• See 7.2(2)

(17) Dynamic load, Broad-band random vibration [B 19.6]

- A. Test method ••• RMS value of acceleration: 13.9m/s². 6 h per axis according to Table 6. (Groups 2 and 3)

Table 6. Broad-band random vibration

| Hz | (m/s ²) ² /Hz |
|-------|--------------------------------------|
| 0 | 5 |
| 55 | 1,625 |
| 180 | 0,0625 |
| 300 | 0,0625 |
| 360 | 0,035 |
| 1 000 | 0,035 |

(18) Continuous contact resistance during (19) with test current [E 14.0]

- A. Test method ••• See 7.2(2)
Continuous contact resistance during (19) with test current (100 mA)
Frequency of measurement: every 10 minutes (Groups 2 and 3)
- B. requirement ••• See 7.2(2)

(19) Mech. shocks(single shocks) [B 19.7]

- A. Test method ••• Acceleration: 30G. Individual shock duration: 6ms. Sinusoidal half-wave. 50 shocks.
(All groups)

(20) One-time disconnection and insertion [B 19.8]

A. Test method • • • Insert and remove once. (All groups)

(21) Dry circuit resistance [E 0.2]

A. Test method • • • See 7.2(1). (All groups)

B. requirement • • • See 7.2(1)

(22) Visual inspection [E 0.1]

A. Test method • • • Visual(e.g. magnifier) and tactile verification.

B. requirement • • • No detrimental deformation.

7.22 Climate load of the housing [LV214 PG 20]

Number of test sample • • • Connector n=5

(1) Visual inspection [E 0.1]

A. Test method • • • Visual(e.g. magnifier) and tactile verification.

B. requirement • • • No detrimental deformation.

(2) Insulation resistance [E 0.3]

A. Test method • • • Measure insulation resistance between all contacts.

Test voltage: 500±50V. Test duration: 60±5s

B. requirement • • • 100MΩ Min.

(3) Aging in dry heat [B 20.1]

A. Test method • • • Age for 120 h in the chamber at 125°C.

(4) Humid heat, constant [B 20.2]

A. Test method • • • Age for 10 days in the chamber at 40°C、RH 95%.

(5) Insulation resistance [E 0.3]

A. Test method • • • Measure insulation resistance between all contacts.

Test voltage: 500±50V. Test duration: 60±5s

Measurement must be taken 30 to 60 mins after the completion of the test (4).

B. requirement • • • 100MΩ Min.

(6) Visual inspection [E 0.1]

A. Test method • • • Visual (e.g. magnifier) and tactile verification.

B. requirement • • • No detrimental deformation.

(7) Low-temperature aging [B 20.3]

A. Test method • • • Age for 48 h in the chamber at -40°C .

(8) Removal and insertion at -20°C [B 20.4]

A. Test method • • • Insert and remove once at -20°C .

B. requirement • • • Must be able to insert and remove at -20°C .

(9) Visual inspection [E 0.1]

A. Test method • • • Visual (e.g. magnifier) and tactile verification.

B. requirement • • • No detrimental deformation.

(10) Aging in dry heat [B 20.5]

A. Test method • • • Age for 48 h in the chamber at 125°C .

(11) Visual inspection [E 0.1]

A. Test method • • • Visual (e.g. magnifier) and tactile verification.

B. requirement • • • No detrimental deformation.

7.23 Long-term temperature aging [LV214 PG 21]

Number of test sample • • • Connector n=5

(1) Visual inspection [E 0.1]

A. Test method • • • Visual (e.g. magnifier) and tactile verification.

B. requirement • • • No detrimental deformation.

(2) Dry circuit resistance [E 0.2]

A. Test method • • • See 7.2(1)

B. requirement • • • See 7.2(1)

(3) Long-term aging in dry heat [B 21.1]

- A. Test method • • • Age for 1000 h in the chamber at 125°C.
Leave for 48 h at room temperature.

(4) Dry circuit resistance [E 0.2]

- A. Test method • • • See 7.2(1)
- B. requirement • • • See 7.2(1)

(5) Functional test with both groups [E 21.1]

- A. Test method • • • Insert and remove 5 times.

(6) Visual inspection [E 0.1]

- A. Test method • • • Visual(e.g. magnifier) and tactile verification.
- B. requirement • • • No detrimental deformation.

7.24 Chemical resistance [LV214 PG 22A]

Number of test sample • • • Connector n=5

(1) Visual inspection [E 0.1]

- A. Test method • • • Visual(e.g. magnifier) and tactile verification.
- B. requirement • • • No detrimental deformation.

(2) Insulation resistance [E 0.3]

- A. Test method • • • Measure insulation resistance between all contacts.
Test voltage: 500±50V. Test duration: 60±5s
Measurement must be taken 30 to 60 mins after the completion of the test (4).
- B. requirement • • • 100MΩ Min.

(3) Resistance of agents (general requirements) [B22.1A]

- A. Test method • • • Expose the sample to commercially available interior cleaner, glass cleaner, Contact spray,
then age for 48 h in the chamber at 125°C

(4) Insulation resistance [E 0.3]

A. Test method • • • Measure insulation resistance between all contacts.

Test voltage: 500 ± 50 V. Test duration: 60 ± 5 s

Measurement must be taken 30 to 60 mins after the completion of the test (4).

B. requirement • • • $100 \text{M}\Omega$ Min.

(5) Visual inspection [E 0.1]

A. Test method • • • Visual (e.g. magnifier) and tactile verification.

B. requirement • • • No detrimental deformation.

7.25 Locking noise [LV214 PG 28]

Number of test sample • • • Connector n=5

(1) Visual inspection [E 0.1]

A. Test method • • • Visual (e.g. magnifier) and tactile verification.

B. requirement • • • No detrimental deformation.

(2) [B 28.1]

A. Test method • • • Leave for 48 h at room temperature.

(3) Locking noise [E 28.1]

A. Test method • • • Measure the locking noise [db] when female connector is inserted into male connector.

Distance to microphone: 600±50mm. Distance from the floor: 1m

B. requirement • • • Must satisfy 70dB(A) min.

Signal-to-noise ratio between the locking noise and ambient noise must be at least 7dB(A).

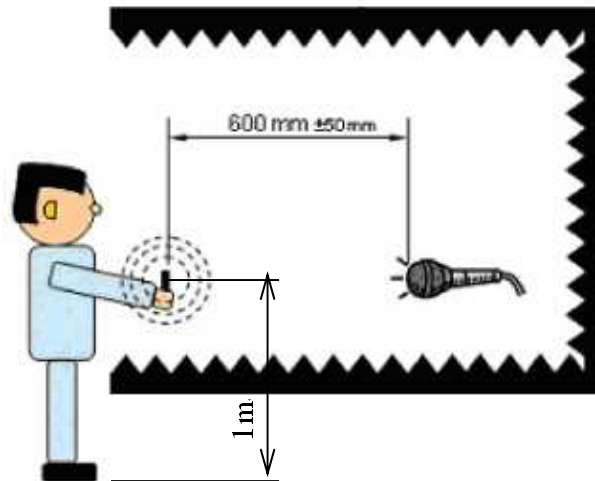

Figure 6. Locking noise

(4) Visual inspection [E 0.1]

A. Test method • • • Visual (e.g. magnifier) and tactile verification.

B. requirement • • • No detrimental deformation.