

ISH[®]VW CONNECTOR

Product Specification

Qualification Test Report No. STR-23006

1	RS0960	August 29, 2023	Y. Nishimura	J. Mukunoki	J. Tateishi
0	RS0942	June 14, 2023	Y. Nishimura	J. Mukunoki	J. Tateishi
Rev.	ECN	Date	Prepared by	Checked by	Approved by

1. Scope : This connector is a 0.5mm terminal miniature wire to wire connector.
2. Purpose : This specification is compliant with LV214.
It covers the Requirements for product performance and test methods of ISHVW CONNECTOR.
3. Application items
This specification is applicable to the items listed below

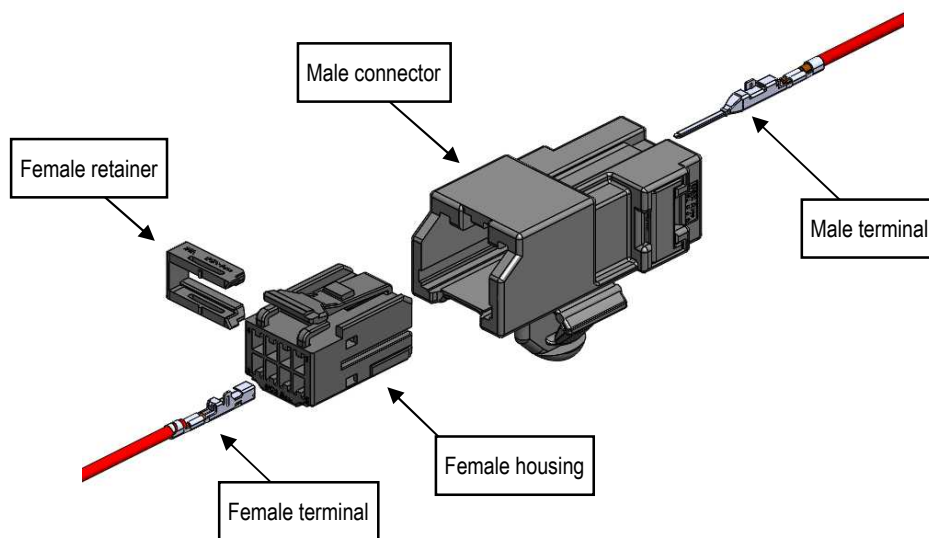

Fig1. Product summary

Table1. Product line

No of poles	Key coding	PARTS No.				
		MALE CONNECTOR	MALE TERMINAL	FEMALE HOUSING	FEMALE RETAINER	FEMALE TERMINAL
8P	A	V0031-008B-201	VT010-01	V0116-91008-02	V0116-92008-01	VT009-**

4. Operating Condition

Temperature Sn : -40~125°C (including temperature rise)

5. Construction, Materials and Finish

5.1 ISHVW CONNECTOR

- (1) MALE HOUSING PBT, UL94-HB, BLACK or NATURAL
- (2) MALE RETAINER Glass-filled PBT, UL94-HB, BLACK
- (3) MALE TERMINAL BRASS, Sn(Reflow)
- (4) FEMALE HOUSING PBT, UL94-HB, BLACK or NATURAL
- (5) FEMALE RETAINER PBT, UL94-HB, BLACK
- (6) FEMALE TERMINAL BOX: BRASS, Sn(Reflow)

Sprig: Copper alloy, Sn (Reflow)

(7) Applicable Cable 0.3mm², 0.5mm²

Outer diameter Φ 1.60mm MAX.

5.3 Terminal crimp specification

Terminal crimp specification compliant with Handling Manual 【HDM-0022】

6. Test Methods and Performances

6.1 Mechanical Performances

Table 2. Mechanical Performances

LV214	PSS-0023 No.	Test item
-	6.2	Electrical Performances Test Method
PG0	6.3	Inspection of as- received condition
PG1	6.4	Dimensions
PG2	6.5	Material and surface analysis, contacts
PG3	6.6	Material and surface analysis, housing
PG4	6.7	Contact engagement length
PG5	6.8	Mechanical and thermal relaxation behavior
PG6	6.9	Interaction between contact and housing
PG7	6.10	Handling and functional reliability of the housing
PG8	6.11	Insertion and retention forces of the contact parts in the housing
PG9	6.12	Insertion inclination/misuse safe(scoop-proofing)
PG10	6.13	Contacts : conductor pull-out strength
PG11	6.14	Contacts : Insertion and removal forces, mating cycle frequency
PG12	6.15	Current heating, derating
PG13	6.16	Housing influence on the derating
PG14	6.17	Thermal time constant (current excess temperature at n times rated current)
PG15	6.18	Electrical stress test
PG16	6.19	Friction corrosion
PG17	6.20	Dynamic load
PG18A	6.20	Coastal climate load
PG18C	6.21	Deicing salt load
PG19	6.21	Environmental simulation
PG20	6.22	Climate load of the housing
PG21	6.23	Long-term temperature aging
PG22A	6.24	Chemical resistance
PG28	6.24	Locking noise

6.2 Electrical Performances Test Method

(1) Dry Circuit Resistance [E0.2]

A. Test method •••Apply current at 20mV (open circuit), 10mA (short circuit).

Measure and record the resistance across A to B and A to C and B to D as illustrated in Figure 2, connection circuit and measurement location.

Calculate the resistance with the following formula.

$$R = R(CD) = R(AB) - R(AC) - R(BD) \quad \text{※}R(AC), R(BD) : \text{Cable conductor resistance}$$

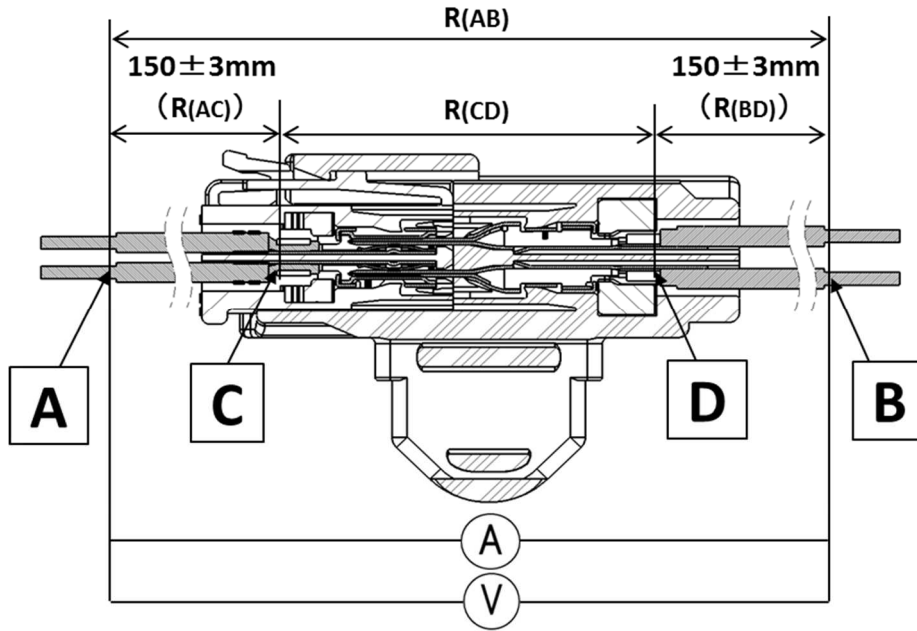

Fig 2. Connection circuit and measurement location

B. Requirement •••Initial: 10mΩ Max. After test: 30mΩ Max.

(2) Continuous contact resistance [E14.0]

A. Test method •••Monitor voltage drop during the test.

B. Requirement •••Record must be maintained.

6.3 Inspection of as-received condition [PG 0]

(1) Visual inspection [E 0.1]

Number of test sample • • • Each part n=5

A. Test method • • • Visual (e.g. magnifier) and tactile verification.

B. Requirement • • • No detrimental deformation.

(2) Dry circuit resistance [E 0.2]

Number of test sample • • • Each part n=5

A. Test method • • • See 6.2(1)

① Contact resistance in contact area.

② Contact resistance in line area will be measured.

B. Requirement • • • See 6.2(1)

(3) Insulation resistance [E 0.3]

Number of test sample • • • Each part n=5

A. Test method • • • Measure insulation resistance between all adjacent contacts.

Test Voltage=500+50V, test time=60±5s

B. Requirement • • • 100MΩ Min.

6.4 Dimensions [PG 1]

Number of test sample • • • Each part n=1

(1) Visual inspection [E 0.1]

A. Test method • • • Visual (e.g. magnifier) and tactile verification.

B. Requirement • • • No detrimental deformation.

(2) Dimensions [E 1.1]

A. Test method • • • Measure dimensions using caliper, micrometer, projector.

B. Requirement • • • Satisfy drawing dimension.

(3) Dimensions of processed components(Crimping part) [E 1.2]

A. Test method • • • Measure dimensions of the crimping part using caliper, micrometer, projector.

B. Requirement • • • Satisfy drawing dimension.

6.5 Material and surface analysis, contacts [PG 2]

Number of test sample • • • Female terminal, Male terminal, n=1

(1) Visual inspection [E 0.1]

- A. Test method • • • Visual (e.g. magnifier) and tactile verification.
- B. Requirement • • • No detrimental deformation.

(2) Material test of contact parts [E 2.1]

- A. Test method • • • Material properties indication for male terminal, female terminal.
Material: material certificate, conductivity, tensile strength, modulus of elasticity
- B. Requirement • • • Record must be maintained. RoHS, ELV directives must be observed.

(3) Markings on the surface [E 2.2]

- A. Test method • • • Check for any dirt or markings on male terminal, female terminal.
- B. Requirement • • • Must satisfy appearance inspection of the inspection standard.

6.6 Material and surface analysis, housings [PG 3]

Number of test sample • • • Male housing, Male retainer, Female housing, Female retainer n=1

(1) Visual inspection [E 0.1]

- A. Test method • • • Visual (e.g. magnifier) and tactile verification.
- B. Requirement • • • No detrimental deformation.

(2) Material test of housings [E 3.1]

- A. Test method • • • Material properties indication for Male housing, Male retainer, Female housing, Female retainer.
 - ① Material: Material certificate
 - ② Measurement of burrs in functional areas
- B. Requirement • • • Record must be maintained. No burrs detrimental to function.

(3) Markings on the surface [E 3.2]

- A. Test method • • • Check for any dirt or markings on assembled parts, Male housing, Male retainer, Female housing, Female retainer.
- B. Requirement • • • Must satisfy appearance inspection of the inspection standard. No burrs on functional area.

6.7 Contact engagement length [PG 4]

Number of test sample ••• Confirmed by the CAD

(1) Contact engagement length [E 4.1]

A. Test method ••• Contact engagement length and required clearance must be calculated based on worst case dimensions.

B. Requirement ••• Contact engagement length : >1.00mm (for all contact points)

Pin clearance : >0mm (worst case dimension)

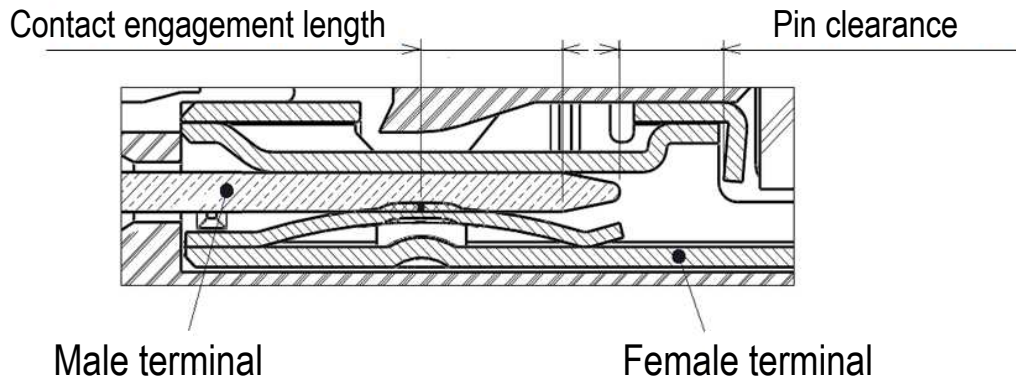

Fig 3. Contact engagement length. Pin clearance

6.8 Mechanical and thermal relaxation behavior [PG 5]

Number of test sample ••• Male connector, Female connector n=5 (Group1 to 6)

(1) Visual inspection [E 0.1]

A. Test method ••• Visual (e.g. magnifier) and tactile verification. (All groups)

B. Requirement ••• No detrimental deformation.

(2) Contact opening dimension [E 5.1]

A. Test method ••• Measure contact opening dimension. (All groups)

B. Requirement ••• Record the measured values.

(3) Insertion and removal before the test (5 times) [B 5.1]

A. Test method ••• Insert and remove the terminal 5 times. (All groups)

(4) Contact opening dimension [E 5.1]

A. Test method ••• Measure contact opening dimension. (All groups)

B. Requirement ••• Record the measured values.

(5) Normal contact force [E 5.2]

- A. Test method • • • Measure normal contact force. (Group 1)
- B. Requirement • • • Record measurement method and measured values.

(6) Insert test sample [B 5.2]

- A. Test method • • • Insert male terminal into female terminal. (Group 2 to 6)

(7) Aging in dry heat, inserted [B 5.3]

- A. Test method • • • Age mated samples in chamber at 105°C.

Remove the sample at each specified timing (1h, 100h, 200h, 500h, and 1000h). (Group 2 to 6)

(8) Visual inspection [E 0.1]

- A. Test method • • • Visual (e.g. magnifier) and tactile verification. (Group 2 to 6)
- B. Requirement • • • No detrimental deformation.

(9) Contact opening dimension [E 5.1]

- A. Test method • • • Measure contact opening dimension. (Group 2 to 6)
- B. Requirement • • • Record the measured values.

(10) Normal contact force [E 5.2]

- A. Test method • • • Measure normal contact force. (Group 2 to 6)
- B. Requirement • • • Record measurement method and measured values.

6.9 Interaction between contact and housing [PG 6]

Number of test sample • • • Male housing, Male retainer, Male terminal, Female housing, Female retainer, Female terminal n=5

(1) Visual inspection [E 0.1]

- A. Test method • • • Visual (e.g. magnifier) and tactile verification.
- B. Requirement • • • No detrimental deformation.

(2) Deflection of contacts in the housing cavity. [E 6.1]

- A. Test method • • • Check drawing dimensions for housing cavity and terminal. (Confirmed by the CAD)
- B. Requirement • • • Can be joined even in the worst case.

(3) Actuation forces for primary lock [E 6.2]

- A. Test method • • • Insert terminal completely into housing, pull out at 10N max.
- B. Requirement • • • Confirm audible click for primary lock.

Confirm that it is locked under tensile strength (10N max.).

(4) Actuation forces for secondary lock [E 6.3]

- A. Test method • • • Insert the retainer with the terminal not in the correct position.
- B. Requirement • • • Insertion is not possible unless terminals are in the correct position.

(5) Visual inspection [E 0.1]

- A. Test method • • • Visual (e.g. magnifier) and tactile verification.
- B. Requirement • • • No detrimental deformation.

(6) Actuation forces for secondary lock [E 6.4]

- A. Test method • • • Fully populate the housing, insert the retainer then remove.
- B. Requirement • • • ① Force when secondary lock is locked: 50N max.
② Force when unlocked: 10N to 50N.

(7) Visual inspection [E 0.1]

- A. Test method • • • Visual (e.g. magnifier) and tactile verification.
- B. Requirement • • • No detrimental deformation.

6.10 Handling and functional reliability of the housing [PG 7]

Number of test sample • • • Male connector, Female housing n=5

(1) Visual inspection [E 0.1]

- A. Test method • • • Visual (e.g. magnifier) and tactile verification.
- B. Requirement • • • No detrimental deformation.

(2) Retention force of the housing latch/lock [E 7.2]

- A. Test method • • • Measure the force required to pull the female housing by a distance of 1mm, and the maximum force.
Female housing is mated without any terminals and locked.
- B. Requirement • • • 60N Min.

6.11 Insertion and retention forces of the contact parts in the housing [PG 8]

Number of test sample • • • Male housing, Male terminal, Female housing, Female terminal n=3(Terminal n=10 Min.)

(1) Visual inspection [E 0.1]

A. Test method • • • Visual (e.g. magnifier) and tactile verification.

B. Requirement • • • No detrimental deformation.

(2) Determination of the contact insertion forces [E 8.1]

A. Test method • • • Determine the peak force required to insert terminal into housing.

B. Requirement • • • 10N Max.

(3) Contact removal force from the housing [E 8.2]

A. Test method • • • Measure the force required to remove the terminal from the housing, by pulling terminal into the opposite direction of insertion.

B. Requirement • • • primary lock : 25N Min., secondary lock : 35N Min.

6.12 Insertion inclination/misuse safe(scoop-proofing) [PG 9]

Number of test sample • • • Confirmed by the CAD

(1) Max. possible insertion inclination [E 9.2]

A. Test method • • • Verify mated state under maximum possible insertion inclination.

(X and Y directions. Z is the insertion direction, confirmed by the CAD)

B. Requirement • • • Must be designed so connector is guided into housing without female terminal settling or male terminal buckling under the worst-case dimensions.

(2) Examination of housing for scoop-proofing [E 9.3]

A. Test method • • • Verify scoop-proofing. (Confirmed by the CAD)

B. Requirement • • • Electrical connection is established only when correctly mated.

No interference between male terminal and female housing.

6.13 Contacts : conductor pull-out strength [PG 10]

Number of test sample • • • Male terminal, Female terminal n=10

(1) Visual inspection [E 0.1]

A. Test method • • • Visual (e.g. magnifier) and tactile verification.

B. Requirement • • • No detrimental deformation.

(2) Conductor pull-out strength [E 10.1]

A. Test method • • • Measure the force required to pull out the conductor from the crimp.

Insulation barrel is not in function.

B. Requirement • • • 50N Min.

6.14 Contacts : Insertion and removal forces, mating cycle frequency [PG 11]

Number of test sample • • • Male connector, Female connector n=5

(1) Visual inspection [E 0.1]

A. Test method • • • Visual (e.g. magnifier) and tactile verification.

B. Requirement • • • No detrimental deformation.

(2) Contact opening dimension [E 5.1]

A. Test method • • • Measure contact opening dimension.

B. Requirement • • • Record the measured values.

(3) Contacts : Insertion and removal forces, mating cycle frequency. [E 11.1]

A. Test method • • • Depending on the plating type, repeat insertion/removal as follows. No addition of lubricant.

Sn:20 times

B. Requirement • • • The insertion force change at the time of contact with the terminal must be up to 25% compared to the initial value.

(4) Contact opening dimension [E 5.1]

A. Test method • • • Measure contact opening dimension.

B. Requirement • • • Record the measured values.

(5) Visual inspection [E 0.1]

A. Test method • • • Visual (e.g. magnifier) and tactile verification.

B. Requirement • • • No detrimental deformation.

6.15 Current heating, derating [PG12]

Number of test sample • • • Male terminal, Female terminal n=3

Cable and length : 200mm

(1) Visual inspection [E 0.1]

A. Test method • • • Visual (e.g. magnifier) and tactile verification.

B. Requirement • • • No detrimental deformation.

(2) Current excess temperature, Derating curve (without housing) [E 12.1, E 12.2]

A. Test method • • • Different current is applied and left for 1 h to stabilize the terminal temperature. (temperature change of terminal must be $\pm 2^{\circ}\text{C}$ min. when measured for 3 times at an interval of 5 minutes)

Measure the ambient temperature at a distance of 50mm min. horizontally from the sample. Record the ambient temperature, surface temperature of the terminal, and current applied.

Create base curve and 80% derating curve from the temperature increase curve.

(3) Visual inspection [E 0.1]

A. Test method • • • Visual (e.g. magnifier) and tactile verification.

B. Requirement • • • No detrimental deformation.

6.16 Housing influence on the derating [PG13]

Number of test sample • • • Male connector, Female connector n=5

Cable and length : 200mm

(1) Visual inspection [E 0.1]

A. Test method • • • Visual (e.g. magnifier) and tactile verification.

B. Requirement • • • No detrimental deformation.

(2) Current excess temperature, Derating curve (with housing) [E 13.1, E 13.2]

A. Test method • • • Different current is applied to DC circuit with all terminal and left for 1 h to stabilize the terminal temperature.

(Temperature change of terminal must be $\pm 2^{\circ}\text{C}$ min. when measured for 3 times at an interval of 5 minutes)

Measure the ambient temperature at a distance of 50mm min. horizontally from the sample. Record the ambient temperature, surface temperature of the terminal, and current applied.

Create base curve and 80% derating curve from the temperature increase curve.

B. Requirement • • • Create temperature increase curve. [E 13.1], Create derating curve. [E 13.2]

(3) Visual inspection [E 0.1]

A. Test method • • • Visual (e.g. magnifier) and tactile verification.

B. Requirement • • • No detrimental deformation.

6.17 Thermal time constant (current excess temperature at n times rated current) [PG 14]

Number of test sample • • • Male terminal, Female terminal n=3

The rated current is the current that can be read from the derating curve at 80°C ambient temperature.

(The derating curve from 7.15(PG12 E12.2))

(1) Visual inspection [E 0.1]

A. Test method • • • Visual (e.g. magnifier) and tactile verification.

B. Requirement • • • No detrimental deformation.

(2) Thermal time constant [E 14.1]

A. Test method • • • Apply current value of 1x, 2x, 3x, 4x, 5x the rated current to single terminal.

(temperature change of terminal must be $\pm 2^{\circ}\text{C}$ min. when measured for 3 times at an interval of 5 minutes) Leave the terminal for 1 hour to stabilize temperature and measure the increase. Temperature increase tolerance: 100°C

B. Requirement • • • Create temperature increase graph.

(3) Visual inspection [E 0.1]

A. Test method • • • Visual (e.g. magnifier) and tactile verification.

B. Requirement • • • No detrimental deformation.

6.18 Electrical stress test [PG 15]

Number of test sample • • • Male connector, Female connector n=5

(1) Visual inspection [E 0.1]

A. Test method • • • Visual (e.g. magnifier) and tactile verification.

B. Requirement • • • No detrimental deformation.

(2) Insertion and removal before the test (2 times) [B 15.1]

A. Test method • • • Insert and remove the connector 2 times.

(3) Contact opening dimension [E 5.1]

A. Test method • • • Measure contact opening dimension.

B. Requirement • • • Record the measured values.

(4) Dry circuit resistance [E 0.2]

A. Test method • • • See 6.2(1)

B. Requirement • • • See 6.2(1)

(5) Derating [E 12.2]

- A. Test method... See 6.16(2)
- B. Requirement... See 6.16(2)

(6) Continuous contact resistance during (7) with test current [E 14.0]

- A. Test method... See 6.2(2)
 Continuous contact resistance during (7) with test current
 Frequency of measurement: every 5 minutes
- B. Requirement... See 6.2(2)

(7) Temperature cycle endurance test/current cycle endurance test [B 15.2]

- A. Test method... Apply current, so the temperature increase is 45°C. $T_0=80^\circ\text{C}$.
 1 cycle (6h) as shown in Fig. 4. Repeat 60 cycles.

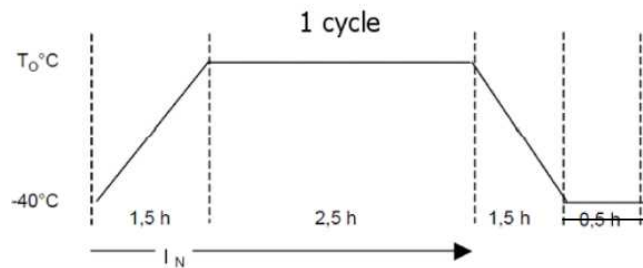

Fig 4. Temperature cycle

(8) Humid heat, cycle [B 15.3]

- A. Test method... Temperature: 25~55°C. Relative humidity: 95%RH.
 1 cycle (24h) as shown in Fig. 5. Repeat 21 cycles.



図 5 / Fig 5. 高温高湿サイクル / Humid heat cycle

(9) Continuous contact resistance during (10) with test current [E 14.0]

A. Test method • • • See 6.2(2)

Continuous contact resistance during (10) with test current

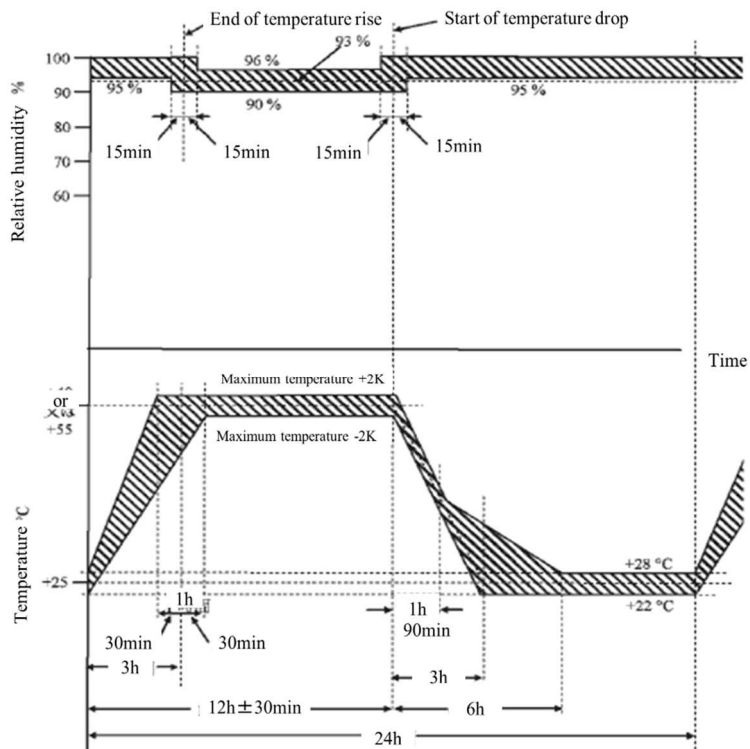
Frequency of measurement: every 5 minutes

B. Requirement • • • See 6.2(2)

(10) Temperature cycle endurance test/current cycle endurance test [B 15.2]

A. Test method • • • Apply current, so the temperature increase is 45°C. $T_0=80^\circ\text{C}$.

1 cycle (6h) as shown in Fig. 4. Repeat 60 cycles.

(11) Dry circuit resistance [E 0.2]

A. Test method • • • See 6.2(1)

B. Requirement • • • See 6.2(1)

(12) Derating [E 12.2]

A. Test method • • • See 6.16(4)

B. Requirement • • • See 6.16(4)

(13) Contact opening dimension [E 5.1]

A. Test method • • • Measure contact opening dimension

B. Requirement • • • Record the measured values.

(14) Visual inspection [E 0.1]

A. Test method • • • Visual (e.g. magnifier) and tactile verification.

B. Requirement • • • No detrimental deformation.

6.19 Friction corrosion [PG 16]

Number of test sample • • • Male terminal, Female terminal n=5

(1) Visual inspection [E 0.1]

A. Test method • • • Visual (e.g. magnifier) and tactile verification.

B. Requirement • • • No detrimental deformation.

(2) Contact resistance, continuous monitoring during (3), recording, and storing [E 16.0]

A. Test method • • • See 6.2(2)

Continuous contact resistance during (3) with test current , Frequency: 4Hz

B. Requirement • • • See 6.2(2)

(3) Friction load [B 16.1]

- A. Test method • • • Insert male terminal into female terminal. Distance of fretting motion: 50µm,
Cycle time : 1Hz、 No. of cycles: 10000 cycles min. Monitor dry circuit resistance during fretting motion MAX.100mV、 10mA
- B. Requirement • • • Create a graph of resistance vs no. of cycles.
Record cycles at dry circuit resistance 300mΩ.

6.20 Dynamic load [PG 17]

Number of test sample • • • Male connector, Female connector n=2(Terminal n=10 Min.)

(1) Visual inspection [E 0.1]

- A. Test method • • • Visual (e.g. magnifier) and tactile verification.
- B. Requirement • • • No detrimental deformation.

(2) Dry circuit resistance [E 0.2]

- A. Test method • • • See 6.2(1)
- B. Requirement • • • See 6.2(1)

(3) Continuous contact resistance during (4) with test current [E 14.0]

- A. Test method • • • See 6.2(2)
Continuous contact resistance during (4) with test current (100 mA)
Frequency of measurement: every 1 minute
- B. Requirement • • • See 6.2(2)

(4) Dynamic load, broad-band random vibration [B 17.2]

- A. Test method • • • Vibration: see Table 4, Sweep speed:1 oct./min

Table 4. Vibration and shock (Body, non-sealed)

TC (temp. cycle)	Random vibration with TC		Sine wave with TC	No. of shocks
	8 h per axis RMS value of acceleration 19.7m/s ²		No sine wave	A=30 G T=6 ms Sinusoidal half-wave No. of shocks : 6000
0 min / 20 °C	Hz	(m/s ²) ² /Hz		
60 min / - 40 °C	10	10		
150 min / - 40 °C	55	3.25		
300 min / 105 °C	180	0.125		
420 min / 105 °C	300	0.125		
480 min / 20 °C	360	0.07		
	1000	0.07		

(5) Visual inspection [E 0.1]

A. Test method • • • Visual (e.g. magnifier) and tactile verification.

B. Requirement • • • No detrimental deformation.

(6) Continuous contact resistance during (7) with test current [E 14.0]

A. Test method • • • See 6.2(2)

Continuous contact resistance during (7) with test current (100 mA)

Frequency of measurement: every 1 minute

B. Requirement • • • See 6.2(2)

(7) Endurance shock test [B 17.3]

A. Test method • • • Vibration: see Table 4, Sweep speed: 1 oct./min

(8) Visual inspection [E 0.1]

A. Test method • • • Visual (e.g. magnifier) and tactile verification.

B. Requirement • • • No detrimental deformation.

(9) Dry circuit resistance [E 0.2]

A. Test method • • • See 6.2(1)

B. Requirement • • • See 6.2(1)

(10) Resonance frequency of the contact assembly [B 17.4]

A. Test method • • • Affix vibration transducer to the housing to determine resonance frequency, based on the conditions below: Dynamic load, sinusoidal, $a = 10 \text{ m/s}^2$, $f = 5 \text{ Hz} - 2000 \text{ Hz} - 5 \text{ Hz}$, Sweep speed = 1 oct./min.

B. Requirement • • • Create a graph of vibration response of the housing.

6.21 Coastal climate load [PG 18A]

Number of test sample • • • Male connector, Female connector $n=2$ (Terminal $n=10$ Min.)

(1) Visual inspection [E 0.1]

A. Test method • • • Visual (e.g. magnifier) and tactile verification.

B. Requirement • • • No detrimental deformation.

(2) Insertion and removal before the test (2 times) [B 15.1]

A. Test method • • • Insert and remove the connector 2 times.

(3) Dry circuit resistance [E 0.2]

- A. Test method . . . See 6.2(1)
- B. Requirement . . . See 6.2(1)

(4) Salt spray, cyclic [B 18.2]

- A. Test method . . . (a) Salt spray [Salt water concentration: $5\pm 1\text{wt}\%$, Temperature: $15\sim 35^\circ\text{C}$]
(b) Humid heat [Temperature: $40\pm 2^\circ\text{C}$, Relative humidity: $90\sim 95\%$]
1 cycle(24h):[(a):2h→(b):22h], Repeat 4 cycle, leave for 3days at
atmosphere[Temperature: $15\sim 35^\circ\text{C}$, Relative humidity: $45\sim 55\%$].

(5) Dry circuit resistance [E 0.2]

- A. Test method . . . See 6.2(1)
- B. Requirement . . . See 6.2(1)

(6) Visual inspection [E 0.1]

- A. Test method . . . Visual (e.g. magnifier) and tactile verification.
- B. Requirement . . . No detrimental deformation.

6.22 Deicing salt load [PG 18C]

Number of test sample . . . Male connector, Female connector $n=2$ (Terminal $n=10$ Min.)

(1) Visual inspection [E 0.1]

- A. Test method . . . Visual (e.g. magnifier) and tactile verification.
- B. Requirement . . . No detrimental deformation.

(2) Insertion and removal before the test (2 times) [B 15.1]

- A. Test method . . . Insert and remove the connector 2 times.

(3) Dry circuit resistance [E 0.2]

- A. Test method . . . See 6.2(1)
- B. Requirement . . . See 6.2(1)

(4) Salt spray, cyclic [B 18.2]

- Test method . . . (a) Salt spray [Salt water concentration: $5\pm 1\text{wt}\%$, Salt mixture (Nordic country salt): 3% salt solution,
of which 95% is NaCl, 2,5% is MgCl₂, and 2,5% is CaCl₂, Temperature: $15\sim 35^\circ\text{C}$]
(b) Humid heat [Temperature: $40\pm 2^\circ\text{C}$, Relative humidity: $90\sim 95\%$] 1 cycle(24h):[(a):2h→(b):22h],
Repeat 4 cycle, leave for 3days at atmosphere[Temperature: $15\sim 35^\circ\text{C}$, Relative humidity: $45\sim 55\%$].

- (5) Dry circuit resistance [E 0.2]
 - A. Test method . . . See 6.2(1)
 - B. Requirement . . . See 6.2(1)

- (6) Visual inspection [E 0.1]
 - A. Test method . . . Visual (e.g. magnifier) and tactile verification.
 - B. Requirement . . . No detrimental deformation.

6.23 Environmental simulation [PG19]

Number of test sample . . . Male connector, Female connector n=5(Group1 to 3)

Table 5. 3 Description of the 3 groups

	Group 1	Group 2	Group 3
No. of contacts	10min.	10min.	10min.
No. of insertion	1	1	Sn : 10
Inserted/Not inserted	Not inserted	Inserted	Inserted
Measurement Method	6.2(1) [E 0.2]	6.2(2) [E 14.0]	6.2(2) [E 14.0]

- (1) Visual inspection [E 0.1]
 - A. Test method . . . Visual (e.g. magnifier) and tactile verification. (All groups)
 - B. Requirement . . . No detrimental deformation.

- (2) Dry circuit resistance [E 0.2]
 - A. Test method . . . See 6.2(1). (All groups)
 - B. Requirement . . . See 6.2(1)

- (3) Inserting and removing [B 19.0]
 - A. Test method . . . Insert/remove connectors for each group according to Table 5.

- (4) Dry circuit resistance [E 0.2]
 - A. Test method . . . See 6.2(1). (All groups)
 - B. Requirement . . . See 6.2(1)

- (5) Continuous contact resistance during (6) with test current [E 14.0]
 - A. Test method . . . See 6.2(2)
 - Continuous contact resistance during (6) with test current (100 mA)
 - Frequency of measurement: every 1 minute (Groups 2 and 3)
 - B. Requirement . . . See 6.2(2)

(6) Temperature shock [B 19.1]

A. Test method . . . — 40°C ⇔ 125°C. 1 cycle = 15 mins. Repeat 144 cycles.

Acclimatization period: 10 sec. max. (All groups)

(7) Continuous contact resistance during (8) with test current [E 14.0]

A. Test method . . . See 6.2(2)

Continuous contact resistance during (8) with test current (100 mA)

Frequency of measurement: every 5 minutes (Groups 2 and 3)

B. Requirement . . . See 6.2 (2)

(8) Temperature cycle [B 19.2]

Test method . . . — 40°C ⇔ 125°C. 1 cycle = 10 h (with 3 h. time for temperature cycle: 2 h max.)

Repeat 20 cycles. (All groups)

(9) Continuous contact resistance during (10) with test current [E 14.0]

A. Test method . . . See 6.2 (2)

Continuous contact resistance during (10) with test current (100 mA)

Frequency of measurement: every 5 minutes. (Groups 2 and 3)

B. Requirement . . . See 6.2 (2)

(10) Aging in dry heat [B 19.3]

A. Test method . . . Age for 120 h in chamber at 125°C. (All groups)

(11) Visual inspection [E 0.1]

A. Test method . . . Visual (e.g. magnifier) and tactile verification. (All groups)

B. Requirement . . . No detrimental deformation.

(12) Industrial climate (multi-component climate)[B 19.4]

A. Test method . . . Age for 21 days in the chamber. Temperature 25°C. Relative humidity: 75%.

Flow rate: 1m³/h. SO₂: 0.2ppm, H₂S: 0.01ppm, NO₂: 0.2ppm, Cl₂: 0.01ppm

(13) Continuous contact resistance during (14) with test current [E 14.0]

A. Test method . . . See 6.2 (2)

Continuous contact resistance during (14) with test current (100 mA)

Frequency of measurement: every 10 minutes (Groups 2 and 3)

B. Requirement . . . See 6.2(2)

(14) Humid heat, cyclic [B 19.5]

- A. Test method • • • Temperature: 25~55°C. Relative humidity: 95%RH.
1 cycle (24h) as shown in Fig. 5. Repeat 10 cycles. (All groups)

(15) Visual inspection [E 0.1]

- A. Test method • • • Visual (e.g. magnifier) and tactile verification.
B. Requirement • • • No detrimental deformation.

(16) Continuous contact resistance during (17) with test current [E 14.0]

- A. Test method • • • See 6.2(2)
Continuous contact resistance during (17) with test current (100 mA)
Frequency of measurement: every 10 minutes (Groups 2 and 3)
- B. Requirement • • • See 6.2(2)

(17) Dynamic load, Broad-band random vibration [B 19.6]

- A. Test method • • • RMS value of acceleration: 13.9m/s². 6 h per axis according to Table 6. (Groups 2 and 3)

Table 6. Broad-band random vibration

Hz	(m/s ²) ² /Hz
0	5
55	1,625
180	0,0625
300	0,0625
360	0,035
1 000	0,035

(18) Continuous contact resistance during (19) with test current [E 14.0]

- A. Test method • • • See 6.2(2)
Continuous contact resistance during (19) with test current (100 mA)
Frequency of measurement: every 10 minutes (Groups 2 and 3)
- B. Requirement • • • See 6.2(2)

(19) Mech. Shocks (single shocks) [B 19.7]

- A. Test method • • • Acceleration: 30G. Individual shock duration: 6ms. Sinusoidal half-wave. 50 shocks. (All groups)

(21) Dry circuit resistance [E 0.2]

- A. Test method • • • See 6.2(1). (All groups)
B. Requirement • • • See 6.2(1)

(22) Visual inspection [E 0.1]

- A. Test method • • • Visual (e.g. magnifier) and tactile verification.
- B. Requirement • • • No detrimental deformation.

6.24 Climate load of the housing [PG 20]

Number of test sample • • • Male connector, Female connector n=5

(1) Visual inspection [E 0.1]

- A. Test method • • • Visual (e.g. magnifier) and tactile verification.
- B. Requirement • • • No detrimental deformation.

(2) Insulation resistance [E 0.3]

- A. Test method • • • Measure insulation resistance between all contacts.
Test voltage: 500±50V. Test duration: 60±5s
- B. Requirement • • • 100MΩ Min.

(3) Aging in dry heat [B 20.1]

- A. Test method • • • Age for 120 h in the chamber at 105°C.

(4) Humid heat, constant [B 20.2]

- A. Test method • • • Age for 10 days in the chamber at 40°C, RH 95%.

(5) Insulation resistance [E 0.3]

- A. Test method • • • Measure insulation resistance between all contacts.
Test voltage: 500±50V. Test duration: 60±5s
Measurement must be taken 30 to 60 mins after the completion of the test (4).
- B. Requirement • • • 100MΩ Min.

(6) Visual inspection [E 0.1]

- A. Test method • • • Visual (e.g. magnifier) and tactile verification.
- B. Requirement • • • No detrimental deformation.

(7) Low-temperature aging [B 20.3]

- A. Test method • • • Age for 48 h in the chamber at -40°C.

(8) Removal and insertion at -20°C [B 20.4]

- A. Test method • • • Insert and remove once at -20°C.
- B. Requirement • • • Must be able to insert and remove at -20°C.

(9) Visual inspection [E 0.1]

- A. Test method . . . Visual (e.g. magnifier) and tactile verification.
- B. Requirement . . . No detrimental deformation.

(10) Aging in dry heat [B 20.5]

- A. Test method . . . Age for 48 h in the chamber at 80°C.

(11) Visual inspection [E 0.1]

- A. Test method . . . Visual (e.g. magnifier) and tactile verification.
- B. Requirement . . . No detrimental deformation.

6.25 Long-term temperature aging [PG 21]

- Number of test sample . . . Male connector, Female housing n=5(group 1)
Male connector, Female connector n=5(group 2)

(1) Visual inspection [E 0.1]

- A. Test method . . . Visual (e.g. magnifier) and tactile verification. (All groups)
- B. Requirement . . . No detrimental deformation.

(2) Dry circuit resistance [E 0.2]

- A. Test method . . . See 6.2(1) (Group 2)
- B. Requirement . . . See 6.2(1)

(3) Long-term aging in dry heat [B 21.1]

- A. Test method . . . Age for 1000 h in the chamber at 125°C. (All groups)
Leave for 48 h at room temperature.

(4) Dry circuit resistance [E 0.2]

- A. Test method . . . See 6.2(1) (Group 2)
- B. Requirement . . . See 6.2(1)

(5) Functional test with both groups [E 21.1]

- A. Test method . . . Insert and remove 5 times.

(6) Contact removal force from the housing [E 8.2]

- Test method . . . Measure the force required to remove the terminal from the housing,
by pulling terminal into the opposite direction of insertion. (Group 2)
- B. Requirement . . . secondary lock : 60N Min.

(7) Visual inspection [E 0.1]

- A. Test method • • • Visual (e.g. magnifier) and tactile verification. (Group 1)
- B. Requirement • • • No detrimental deformation.

6.26 Chemical resistance [PG 22A]

Number of test sample • • • Male connector, Female connector n=5

(1) Visual inspection [E 0.1]

- A. Test method • • • Visual (e.g. magnifier) and tactile verification.
- B. Requirement • • • No detrimental deformation.

(2) Insulation resistance [E 0.3]

- A. Test method • • • Measure insulation resistance between all contacts.
Test voltage: 500±50V. Test duration: 60±5s
- B. Requirement • • • 100MΩ Min.

(3) Resistance to agents (general Requirements)

- Test method • • • Export the connector to commercially available Interior cleaner, Penetration oil,
Undiluted washer fluid antifreeze, Isopropanol, Grease then age for 48h in the chamber at 125°C.

(4) Insulation resistance [E 0.3]

- A. Test method • • • Measure insulation resistance between all contacts.
Test voltage: 500±50V. Test duration: 60±5s
- B. Requirement • • • 100MΩ Min.

(5) Visual inspection [E 0.1]

- A. Test method • • • Visual (e.g. magnifier) and tactile verification.
- B. Requirement • • • No detrimental deformation.

7.27 Locking noise [PG 28]

Number of test sample • • • Male connector, Female connector n=5

(1) Visual inspection [E 0.1]

A. Test method • • • Visual (e.g. magnifier) and tactile verification.

B. Requirement • • • No detrimental deformation.

(2) Aging [B 28.1]

A. Test method • • • Leave for 24 h at room temperature.

(3) Locking noise [E 28.1]

A. Test method • • • Measure the locking noise [dB] when female connector is inserted into male connector.

Distance to microphone: 600 ± 50 mm. Distance from the floor: 1 m

B. Requirement • • • Must satisfy 70dB(A) min.

Signal-to-noise ratio between the locking noise and ambient noise must be at least 7dB(A).

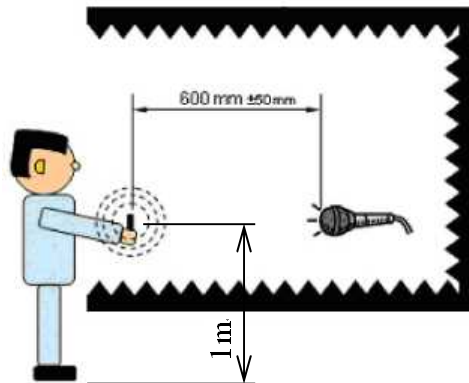

Fig 6. Locking noise

(4) Visual inspection [E 0.1]

A. Test method • • • Visual (e.g. magnifier) and tactile verification.

B. Requirement • • • No detrimental deformation.