

CABLINE®-VS

Part No. Plug: 20453-##*T-### Receptacle: 20455-##*E-###

Product Specification

Qualification Test Report No. TR-08047,13084,16002

12	S19680	October 31, 2019	Y. Sasa	T. Masunaga	H. Ikari
11	S18674	October 22, 2018	Y. Miyazaki	T. Masunaga	H. Ikari
10	S18247	July 2, 2018	A. Koyanagi	T. Masunaga	H. Ikari
9	S15239	Sept. 29 2015	H. Ikari	-	Y. Shimada
Rev.	ECN	Date	Prepared by	Checked by	Approved by

CABLIN-VS Product Specification

1. 適応範囲／Scope

本規格は、コンタクトピッチ 0.5mm の基板対ワイヤーコネクタである CABLINE-VS コネクタの性能と試験条件について規定する。
This Product Specification defines the test conditions and the performances of the CABLINE-VS Connector, a wire-to-board connector of 0.5mm contact pitch.

2. 製品名称及び製品型番／Product Name and Parts No.

2.1 製品名称／Product Name

CABLIN-VS

2.2 製品型番／Parts No.

2.2.1 組み合わせ 1

Plug: 20453-0**T-###

Receptacle: 20455-***E-#2#

2.2.2 組み合わせ 2

Plug: 20453-2**T-###

Receptacle: 20455-***E-#6#

2.2.3 組み合わせ 3

Plug: 20453-3**T-###

Receptacle: 20455-***E-#9#

3. 定格／Rating

3.1 適応ケーブル／Applicable Cable

AWG# [44,42,40,38,36,34,32]

3.2 使用条件／Operating Conditions

電流／Amperage: 0.1A AC/DC [AWG#44] (Per contact/Up to 50 contacts)
0.24A AC/DC [AWG#42] (Per contact/Up to 50 contacts)
0.3A AC/DC [AWG#40] (Per contact/Up to 50 contacts)
0.5A AC/DC [AWG#38] (Per contact/Up to 14 contacts)
0.8A AC/DC [AWG#36] (Per contact/Up to 10 contacts)
1.0A AC/DC [AWG#34] (Per contact/Up to 6 contacts)
1.0A AC/DC [AWG#32] (Per contact/Up to 6 contacts)

電圧／Voltage: 100V AC (Per contact)

使用温度／Operating temperature: 233~358K(-40℃~85℃)

(通電による温度上昇含む／Containing temperature rise by current)

使用湿度／Operating humidity: 85% max

3.3 保管条件／Storage Conditions

保管温度／Storage temperature: 248~333K(-25℃~60℃)

保管湿度／Storage humidity: 85% max. (結露無きこと／Non-condensing)

保管期間／Storage period: 納入後 1 年以内 (弊社梱包状態)／
Within 1 year after delivery (Our packing state)

4. 試験及び性能／Test and Performance

試験条件／Test Condition

特に指定のない限り、測定と試験は、MIL-STD-202G に基づき以下の条件で行う。

This initial test is equal to it's at shipping condition and unless otherwise specified, all tests and measurements shall be performed under the following conditions in accordance with MIL-STD-202 G.

温度／Temperature... 288K~308K (15℃~35℃)

気圧／Pressure... 866hPa~1066hPa (650mmHg~800mmHg)

相対湿度／Relative humidity... 45~75%R.H.

4.1.電氣的性能 / Electrical Performance

1. 接触抵抗 Contact resistance

Reference standard: MIL-STD-202G, Method 307

試験条件: テスト基板にリセプタクルコネクタを半田付けし、プラグコネクタを嵌合させ、開回路電圧 20mV DC 以下、短絡電流 10mA DC 以下で 4 端子法に芯線及びシールド線の図 1 に示す区間の接触抵抗を測定する。

Test conditions: Solder the receptacle connector to the test board and mate the plug connector together, then measure the contact resistance as shown in Fig.1 by the four terminal methods. Apply the low level condition of 20mV MAX. DC for the open circuit voltage and 10mA MAX. DC for the closed circuit current.

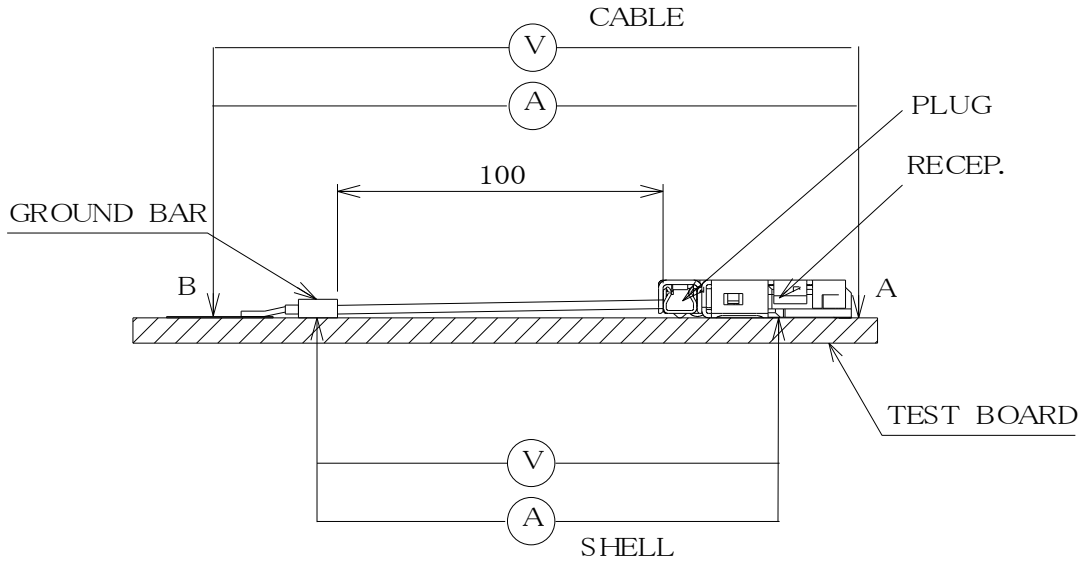

Fig.1

合格基準: **コンタクト**
 初期: 140 mΩMAX.(AWG#32) 180 mΩMAX.(AWG#34) 275 mΩMAX.(AWG#36)
 360 mΩMAX.(AWG#38) 600 mΩMAX.(AWG#40) 700 mΩMAX.(AWG#42)
 1080 mΩMAX.(AWG#44)

試験後: ΔR 40mΩ MAX

初期値は、以下に示すケーブル 100 mm の導体抵抗を含む。

60 mΩMAX.(AWG#32) 100 mΩMAX.(AWG#34) 195 mΩMAX.(AWG#36)
 280 mΩMAX.(AWG#38) 520 mΩMAX.(AWG#40) 620 mΩMAX.(AWG#42)
 1000 mΩMAX.(AWG#44)

グラウンドコンタクト

初期: 50 mΩ MAX. 試験後: ΔR40 mΩ MAX.

Pass criteria:

Contact

Initial: 140 mΩMAX.(AWG#32) 180 mΩMAX.(AWG#34) 275 mΩMAX.(AWG#36)
 360 mΩMAX.(AWG#38) 600 mΩMAX.(AWG#40) 700 mΩMAX.(AWG#42)
 1080 mΩMAX.(AWG#44)

After testing: ΔR40 mΩ MAX.

Initial contains the following conductor resistance of a cable 100 mm.

60 mΩMAX.(AWG#32) 100 mΩMAX.(AWG#34) 195 mΩMAX.(AWG#36)
 280 mΩMAX.(AWG#38) 520 mΩMAX.(AWG#40) 620 mΩMAX.(AWG#42)
 1000 mΩMAX.(AWG#44)

Ground contact

Initial: 50 mΩ MAX. After testing: ΔR 40 mΩ MAX.

4.1.電氣的性能／Electrical Performance**2. 絶縁抵抗 Insulation resistance**

Reference standard: MIL-STD-202 G, Method 302

試験条件: リセプタクル及びプラグコネクタを嵌合させた状態で、中心導体と外部導体の間に DC250V を印加し、測定する。

Test conditions: Mate the plug and receptacle connector together, and then apply DC 250 V between the inner contact and the ground contact.

合格基準: 初期: 1000 MΩ MIN. 試験後: 500 MΩ MIN.

Pass criteria: Initial: 1000 MΩ MIN. After testing: 500 MΩ MIN.

3. 耐電圧 Dielectric withstanding voltage

Reference standard: MIL-STD-202 G, Method 301

試験条件: リセプタクル及びプラグコネクタを嵌合させ、隣接する端子間に AC250V (実効値) を一分間印加する。

Test conditions: Mate the receptacle and plug connector together, then apply AC 250V(rms) between the neighboring contacts for a minute.

合格基準: 沿面放電、空中放電、絶縁破壊等の異常無きこと。

Pass criteria: No creeping discharge, flashover, no insulator breakdown shall occur.

4. 温度上昇 Temperature rising

Reference standard: -

試験条件: リセプタクル及びプラグコネクタを互いに嵌合させ、各コネクタに定格電流を通電、周囲温度上昇を測定する。

Test conditions: Mate the plug and receptacle connector together and then apply rating current per contact.

合格基準: 温度上昇 ΔT30 °C MAX.

Pass criteria: Over ambient ΔT30 °C MAX.

CABLINE-VS Product Specification

4.2.機械的性能／Mechanical Performance

1. 挿抜力 Mating force and Un-mating force											
Reference standard: -											
試験条件:	テスト基板にリセプタクルを半田付けする。その後、試料を挿抜試験機に取り付け、嵌合軸に平行に毎分 25±3mm の速度で、初期及び 30 回目の挿入抜去力を測定する。										
Test conditions:	Solder the receptacle connector to the test board, then place the board and plug on push-on/pull-off machine, measure of initial and mating/unmating 30 cycles at a speed 25±3mm/min. along the mating axis.										
合格基準:	<table border="0"> <tr> <td>挿入力</td> <td>抜去力</td> </tr> <tr> <td>20 P: 9.45 N MAX.</td> <td>20 P: 2.0 N MIN.</td> </tr> <tr> <td>30 P: 12.15 N MAX.</td> <td>30 P: 3.0 N MIN.</td> </tr> <tr> <td>40 P: 16.2 N MAX.</td> <td>40 P: 4.0 N MIN.</td> </tr> <tr> <td>50 P: 20.25 N MAX.</td> <td>50 P: 5.0 N MIN.</td> </tr> </table>	挿入力	抜去力	20 P: 9.45 N MAX.	20 P: 2.0 N MIN.	30 P: 12.15 N MAX.	30 P: 3.0 N MIN.	40 P: 16.2 N MAX.	40 P: 4.0 N MIN.	50 P: 20.25 N MAX.	50 P: 5.0 N MIN.
挿入力	抜去力										
20 P: 9.45 N MAX.	20 P: 2.0 N MIN.										
30 P: 12.15 N MAX.	30 P: 3.0 N MIN.										
40 P: 16.2 N MAX.	40 P: 4.0 N MIN.										
50 P: 20.25 N MAX.	50 P: 5.0 N MIN.										
Pass criteria:	<table border="0"> <tr> <td>Mating force</td> <td>Unmating force</td> </tr> <tr> <td>20 P: 9.45 N MAX.</td> <td>20 P: 2.0 N MIN.</td> </tr> <tr> <td>30 P: 12.15 N MAX.</td> <td>30 P: 3.0 N MIN.</td> </tr> <tr> <td>40 P: 16.2 N MAX.</td> <td>40 P: 4.0 N MIN.</td> </tr> <tr> <td>50 P: 20.25 N MAX.</td> <td>50 P: 5.0 N MIN.</td> </tr> </table>	Mating force	Unmating force	20 P: 9.45 N MAX.	20 P: 2.0 N MIN.	30 P: 12.15 N MAX.	30 P: 3.0 N MIN.	40 P: 16.2 N MAX.	40 P: 4.0 N MIN.	50 P: 20.25 N MAX.	50 P: 5.0 N MIN.
Mating force	Unmating force										
20 P: 9.45 N MAX.	20 P: 2.0 N MIN.										
30 P: 12.15 N MAX.	30 P: 3.0 N MIN.										
40 P: 16.2 N MAX.	40 P: 4.0 N MIN.										
50 P: 20.25 N MAX.	50 P: 5.0 N MIN.										

2. 耐久性 Durability	
Reference standard: -	
試験条件:	テスト基板にリセプタクルを半田付けする。その後、試料を挿抜試験機に取り付け、嵌合軸に平行に毎分 25±3mm の速度で、30 回挿入抜去を行う。
Test conditions:	Solder the receptacle connector to the test board, then place the board and plug on the push-on/pull-off machine, and repeat mating and unmating 330cycles at a speed 25±3mm/min. along the mating axis.
合格基準:	接触抵抗: 4.1.1 を満足する事。
Pass criteria:	Contact resistance: Shall meet 4.1.1

3. 端子保持力 Contact retention force	
Reference standard: -	
試験条件:	コネクタを挿抜試験機に取り付け、毎分 25±3mm の速度で端子の軸に沿って、端子に圧入と逆方向の荷重を加え、端子がコネクタより抜ける時の荷重を測定する。
Test conditions:	Place the connector on the push-on/pull-off machine, then apply force on the contact head and push the contact along the direction opposite to the contact insertion at a speed of 25±3mm/min. Measure the force when the contact dislodges the connector.
合格基準:	<p>プラグ端子保持力: 0.6N MIN. リセプタクル端子保持力: 0.2N MIN.</p>
Pass criteria:	<p>Plug contact retention force: 0.6N MIN. Receptacle contact retention force: 0.2N MIN.</p>

CABLIN-VS Product Specification

4.2.機械的性能／Mechanical Performance

4. ケーブル保持力 Cable retention force	
Reference standard:	-
試験条件:	プラグコネクタを挿抜試験機に取り付け、毎分 25±3mm の速度でケーブル引き出し方向に荷重を加え、瞬断時の荷重を測定する。
Test conditions:	Place the plug connector on the push-on/pull-off machine and then apply force on the cable along the direction at a speed 25±3mm/min. Measure the force when the cable dislodges the plug connector.
合格基準:	20 P: 9.80 N MIN. 30 P: 14.70 N MIN. 40 P: 19.60 N MIN. 50 P: 24.50 N MIN.
Pass criteria:	

5. 耐振動性 Vibration	
Reference standard:	MIL-STD-202 G, Method 201 A
試験条件:	テスト基板にリセプタクルコネクタを半田付けし、プラグコネクタと嵌合させ振動試験機に取り付け、以下の振動を加える。試験中 100mA DC の電流を流して電氣的瞬断を確認する。 周波数: 10Hz→55Hz→10Hz/約 1 分 方向: 3 つの互いに直角な方向 全振幅: 1.52mm 掃引時間: 各方向に 2 時間、計 6 時間
Test conditions:	Solder the receptacle connector to the test board, then mate plug connector, and place them on the vibrator. Then apply the following vibration. During the testing, run 100mA DC to check electrical discontinuity. Frequency: 10Hz→55Hz→10Hz/approx. 1min. Directions: 3 mutually perpendicular direction. Total Amplitude: 1.52mm Sweep duration: 2 hours for each direction, a total of 6 hours.
合格基準:	接触抵抗: 4.1.1 を満足する事。 瞬断: 試験中、1μs を超える電氣的瞬断の無き事。 外観: 異常無き事。
Pass criteria:	Contact resistance: Shall meet 4.1.1. Electrical discontinuity: No electrical discontinuity greater than 1μs shall occur. Appearance: No abnormality

6.耐衝撃性 Shock	
Reference standard:	MIL-STD-202 G, Method 213 B, Condition A.
試験条件:	テスト基板にリセプタクルコネクタを半田付けし、プラグコネクタと嵌合させ衝撃試験機に取り付け、以下の衝撃を加える。試験中 100mA DC の電流を流して電氣的瞬断を確認する。 最大加速度: 50G 標準持続時間: 11msec. 波形: 半波正弦波 方向: 直交する 6 方向 回数: 各 3 回
Test conditions:	Solder the receptacle connector to the test board, then mate plug connector, and place them on the shock machine. Then apply the following shock. MAX.G: 50G Duration: 11msec Wave Form: Half Sinusoidal Directions: 6 mutually perpendicular direction Cycle: 3 cycles about each direction
合格基準:	接触抵抗: 4.1.1 を満足する事。 瞬断: 試験中、1μs を超える電氣的瞬断の無き事。 外観: 異常無き事。
Pass criteria:	Contact resistance: Shall meet 4.1.1. Electrical discontinuity: No electrical discontinuity greater than 1μs shall occur. Appearance: No abnormality

CABLIN-VS Product Specification

4.3.耐環境性能 / Environmental Performance

1. 熱衝撃 Thermal shock

Reference standard: MIL-STD-202 G, Method 107 G, Condition A.

試験条件: テスト基板にリセプタクルコネクタを半田付けし、プラグコネクタと嵌合させ、以下の環境条件に暴露する。
 温度: 218K(-55℃),30分→358K(85℃),30分
 移動時間: 5分 MAX.
 回数: 5サイクル

Test conditions: Solder the receptacle connector to the test board, then mate plug connector, and expose them to the following environment.
 Temperature: 218K(-55℃),30min.→358K(85℃),30min.
 Transition time: 5min. MAX.
 No. of cycles: 5 cycles

合格基準: 接触抵抗: 4.1.1.を満足する事。

Pass criteria: Contact resistance: Shall meet 4.1.1.

2. 高温寿命 High temperature life

Reference standard: MIL-STD-202 G, Method 108 A, Condition B.

試験条件: テスト基板にリセプタクルコネクタを半田付けし、プラグコネクタと嵌合させ、以下の環境条件に暴露する。
 温度: 358±2K (85±2℃)
 期間: 250時間

Test conditions: Solder the receptacle connector to the test board, then mate plug connector, and expose them to the following environment.
 Temperature: 358±2K (85±2℃)
 Duration: 250 hours

合格基準: 接触抵抗: 4.1.1.を満足する事。

端子保持力: 4.2.3.を満足する事。

Pass criteria: Contact resistance: Shall meet 4.1.1.

Contact retention force: Shall meet 4.2.3.

CABLIN-VS Product Specification

4.3.耐環境性能/Environmental Performance

3. 湿度(定常状態) Humidity(Steady state)

Reference standard: MIL-STD-202 G, Method 103 B, Condition A.

試験条件: テスト基板にリセプタクルコネクタを半田付けし、プラグコネクタと嵌合させ、以下の環境条件に暴露する。
 温度: 313±2K (40±2℃)
 湿度: 90~95%RH
 期間: 240 時間

Test conditions: Solder the receptacle connector to the test board, then mate plug connector, and expose them to the following environment.
 Temperature: 313±2K (40±2℃)
 Humidity: 90~95%RH
 Duration: 240 hours

合格基準: 接触抵抗: 4.1.1.を満足する事。
 絶縁抵抗: 4.1.2.を満足する事。
 耐電圧: 4.1.3.を満足する事。

Pass criteria: Contact resistance: Shall meet 4.1.1.
 Insulation resistance: Shall meet 4.1.2.
 Dielectric withstanding voltage: Shall meet 4.1.3.

4. 湿度(サイクリング) Humidity(Cycling)

Reference standard: MIL-STD-202 G, Method 106 G.

試験条件: テスト基板にリセプタクルコネクタを半田付けし、プラグコネクタと嵌合させ、以下の環境条件に暴露する。
 温度: 298[263]~338K (25[-10]~65℃)
 湿度: 90~98%RH
 期間: 10 サイクル (240 時間)

Test conditions: Solder the receptacle connector to the test board, then mate plug connector, and expose them to the following environment.
 Temperature: 298[263]~338K (25[-10]~65℃)
 Humidity: 90~98%RH
 Duration: 10cycles (240hours)

合格基準: 接触抵抗: 4.1.1.を満足する事。
 絶縁抵抗: 4.1.2.を満足する事。
 耐電圧: 4.1.3.を満足する事。

Pass criteria: Contact resistance: Shall meet 4.1.1.
 Insulation resistance: Shall meet 4.1.2.
 Dielectric withstanding voltage: Shall meet 4.1.3.

CABLINE-VS Product Specification

4.3.耐環境性能 / Environmental Performance

5. 塩水噴霧 Salt water spray

Reference standard: MIL-STD-202 G, Method 101 E, Condition B

試験条件: テスト基板にリセプタクルコネクタを半田付けし、プラグコネクタと嵌合させ、以下の環境条件に暴露する。
 温度: $308 \pm 2\text{K}$ ($35 \pm 2^\circ\text{C}$)
 塩水濃度: $5 \pm 1\%$ [重量比]
 期間: 48 時間

Test conditions: Solder the receptacle connector to the test board, then mate plug connector, and expose them to the following environment.
 Temperature: $308 \pm 2\text{K}$ ($35 \pm 2^\circ\text{C}$)
 Salt water density: $5 \pm 1\%$ [by weight]
 Duration: 48 hours

合格基準: 接触抵抗: 4.1.1.を満足する事。
 外観: 異常無き事。

Pass criteria: Contact resistance: Shall meet 4.1.1.
 Appearance: No abnormality

6. 硫化水素ガス H₂S gas

Reference standard: -

試験条件: テスト基板にリセプタクルコネクタを半田付けし、プラグコネクタと嵌合させ、以下の環境条件に暴露する。
 温度: $313 \pm 2\text{K}$ ($40 \pm 2^\circ\text{C}$)
 相対湿度: $80 \pm 5\%$ RH
 ガス: H₂S $3 \pm 1\text{ppm}$
 期間: 48 時間

Test conditions: Solder the receptacle connector to the test board, then mate plug connector, and expose them to the following environment.
 Temperature: $313 \pm 2\text{K}$ ($40 \pm 2^\circ\text{C}$)
 Relative humidity: $80 \pm 5\%$ RH
 Gas: H₂S $3 \pm 1\text{ppm}$
 Duration: 48 hours

合格基準: 接触抵抗: 4.1.1.を満足する事。
 性能上有害な異常の無い事。

Pass criteria: Contact resistance: Shall meet 4.1.1.
 Appearance: No abnormality adversely affecting the performance shall occur.

4.4.その他/Others

1. 半田付け性 Solder ability

Reference standard: -

試験条件: 端子の半田付け部を $518 \pm 5K$ ($245 \pm 5^\circ C$) の半田槽内に 5 ± 0.5 秒間浸す。フラックスは、RMA 型または R 型を使用し、5~10 秒間浸漬するものとする。

Test conditions: Dip the solder tine of the contact in the solder bath at $518 \pm 5K$ ($245 \pm 5^\circ C$) for 5 ± 0.5 seconds after immersing the tine in the flux of RMA or R type for 5 to 10 seconds.

合格基準: 浸した面線の 95% 以上に半田がむらなく付着すること。
Pass criteria: More than 95% of the dipped surface shall be evenly wet.

2. 半田耐熱性 (リフロー) Soldering heat resistance (Reflow)

Reference standard: -

試験条件: リフロー温度プロファイルは図 2 を参照。リフロー回数は 2 回以内。

Test conditions: Reflow temperature as shown in Fig.2.
The number of times of Reflow is within 2.

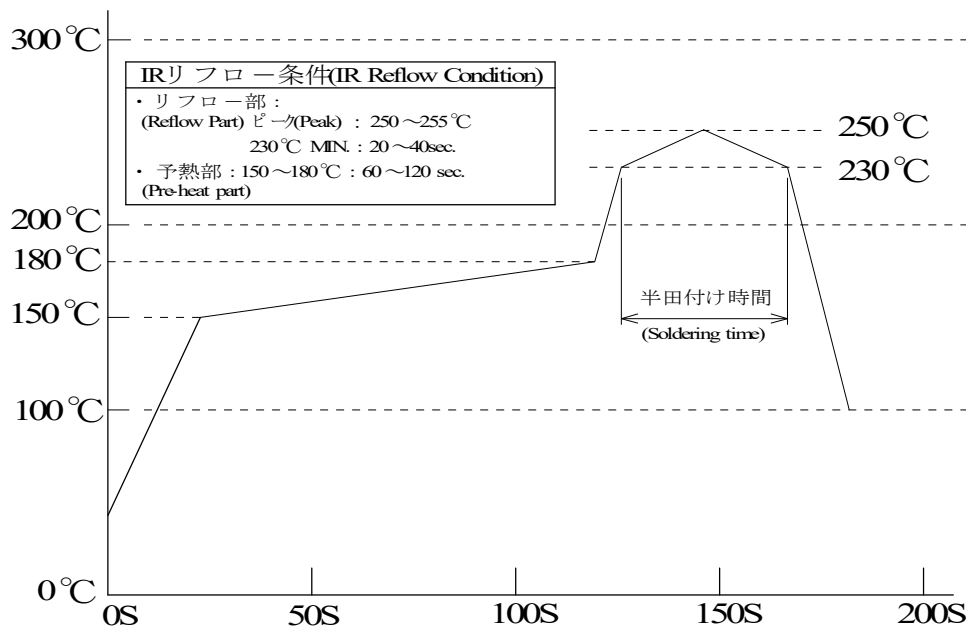

Fig.2

合格基準: 機能を損なう変形及び欠陥の無き事。
Pass criteria: No abnormality adversely affecting the performance shall not occur.

3. 半田耐熱性 (手半田) Soldering heat resistance (Soldering iron)

Reference standard: -

試験条件: 半田こて先温度: $613 \sim 633K$ ($350^\circ C \pm 10$)
こて先当て時間: 5 ± 1 秒
加熱回数: 3 回

Test conditions: Operating temperature: $613 \sim 633K$ ($350^\circ C \pm 10$)
Application time of soldering iron: 5 ± 1 sec.
The number of times of Application: 3 times

合格基準: 機能を損なう変形及び欠陥の無き事。
Pass criteria: No abnormality adversely affecting the performance shall not occur.

4.5 試験順序と試料数 / Test Sequence and Specimen Quantity

Table 1 試験順序と試料数 / Test Sequence and Sample Quantity

試験項目 Test Item	グループ / Group											
	A	B	C	D	E	F	G	H	J	K	L	M
接触抵抗 Contact Resistance	2,6		1,3,5	1,3	1,3	1,5	1,5,7	1,3	1,3			
絶縁抵抗 Insulation Resistance						2,6	2,8					
耐電圧 D. W. Voltage						3,7	3,9					
温度上昇 Temperature rising												1
挿入力 Mating Force	1,5											
抜去力 Un-mating Force	3,7											
耐久性 Durability	4						4					
端子保持力 Contact Retention Force		1,3										
ケーブル保持力 Cable Retention Force	8											
耐振動性 Vibration			2									
耐衝撃性 Shock			4									
熱衝撃 Thermal Shock				2								
高温寿命 High Temperature Life		2			2							
湿度 (定常状態) Humidity (Steady State)						4						
湿度 (サイクリング) Humidity (Cycling)							6					
塩水噴霧 Salt Water Spray								2				
硫化水素ガス H2S Gas									2			
半田付け性 Solder ability										1		
半田耐熱性 Soldering Heat Resistance											1	
試料数 Specimen Quantity.	5 pcs.	20 pos.	5 pcs.	5 pcs.	5 pcs.	5 pcs.	5 pcs.	5 pcs.	5 pcs.	10 pcs.	10 pcs.	5 pcs.

※グループ表中の番号は、試験順序を示す。 / Numbers indicate sequence in which tests are performed.

5. 推奨メタルマスク Recommended Metal Mask

推奨メタルマスク厚 Recommended Metal Mask Thickness t = 0.12mm

推奨メタルマスク開口率 Recommended Metal Mask Opening Rate 100%