

CABLINE®-UY Connector

Part No. Plug: 20857-0**T-01-# Receptacle: 20854-0**E-02-#

Product Specification

Qualification Test Report No. TR-19084

7	S26232	June 24, 2026	R. Minohara	T. Tanigawa	T. Masunaga
6	S25252	June 6, 2025	R. Minohara	T. Tanigawa	H. Ikari
5	S24085	February 26, 2024	R. Hatano	T. Tanigawa	H. Ikari
4	S23376	October 20, 2023	W. Lau	Y. Shimizu	M. Takemoto
Rev.	ECN	Date	Prepared by	Checked by	Approved by

1. Scope

This Product Specification defines the test conditions and the performances of the CABLINE-UY Connector , a wire-to-board connector of 0.35mm contact pitch.

2. Product Name and Parts No.

2.1 Product Name

CABLINE-UY Connector

2.2 Parts No.

Plug cable assembly: 20857-0**T-01-#

Receptacle: 20854-0**E-02-#

3. Rating

3.1 Applicable Cable

Micro-coaxial cable . . . AWG# [42, 40]

Discrete wire . . . AWG# [36]

3.2 Operating Conditions

Amperage : 0.35A AC/DC [AWG#42] (Per Contact Pin/Up to 10 Contacts)

0.38A AC/DC [AWG#40] (Per Contact Pin/Up to 10 Contacts)

0.50A AC/DC [AWG#36] (Per Contact Pin/Up to 10 Contacts)

※Testing by a real machine is recommended because temperature rise may be affected by actual situation.

Voltage: AC 60Vr.m.s (per contact pin)

Operating temperature: 233~358K(-40°C~+85°C)

(Containing temperature rise by current)

Operating humidity: 85% max

3.3 Storage Conditions

Storage temperature: 248~333K(-25°C~60°C)

Storage humidity: 85% max. (Non-condensing)

4. Test and Performance

Test Condition

This initial test is equal to it's at shipping condition and unless otherwise specified,

all tests and measurements shall be performed under the following conditions in accordance with MIL-STD-202.

Temperature... 288K~308K (15°C~35°C)

Pressure... 866hPa~1066hPa (650mmHg~800mmHg)

Relative humidity... 45~75%R.H.

4.1. Electrical Performance

1. Contact resistance

Reference standard: MIL-STD-202G, Method 307

Test conditions: Solder the receptacle connector to the test board and mate the plug connector together, then measure the contact resistance as shown in Fig.1 by the four terminal methods. Apply the low level condition of 20mV MAX. DC for the open circuit voltage and 10mA MAX. DC for the closed circuit current.

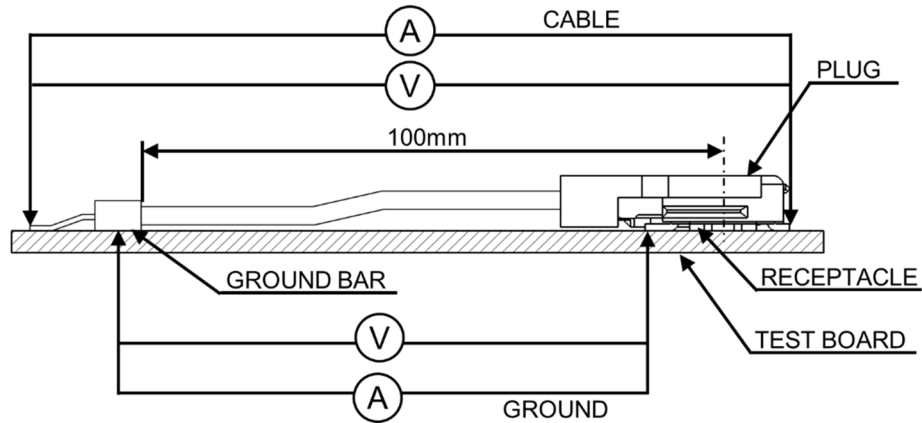

Fig.1

Pass criteria:

Contact
 Initial: 275 mΩ MAX. (AWG#36)
 600 mΩ MAX. (AWG#40)
 700 mΩ MAX. (AWG#42)
 After testing: ΔR 40 mΩ MAX.
 Initial contains the following conductor resistance of a cable 100 mm.
 195 mΩ (AWG#36)
 520 mΩ (AWG#40)
 620 mΩ (AWG#42)
 Ground shell
 Initial: 60 mΩ MAX. After testing: ΔR 40 mΩ MAX.

2. Insulation resistance

Reference standard: MIL-STD-202 G, Method 302

Test conditions: Mate the plug and receptacle connector together, and then apply DC 100 V between the inner contact and the SHELL A.

Pass criteria: Initial: 500 MΩ MIN. After testing: 100 MΩ MIN.

4.1. Electrical Performance

3. Dielectric withstanding voltage	
Reference standard:	MIL-STD-202 G, Method 301
Test conditions:	Mate the receptacle and plug connector together, then apply AC 200V(rms) between the neighboring contacts for a minute.
Pass criteria:	No abnormalities such as creeping discharge, flashover, insulator breakdown occur.

4. Temperature rising	
Reference standard:	-
Test conditions:	Mate the plug and receptacle connector together and then apply rating current per contact pin.
Pass criteria:	Over ambient $\Delta T=30$ °C MAX.

4.2. Mechanical Performance

1. Mating force and Unmating force	
Reference standard:	-
Test conditions:	Solder the receptacle connector to the test board, then place the board and plug on push-on/pull-off machine, measure of initial and mating/unmating 30 cycles at a speed 25 ± 3 mm/min. along the mating axis.
Pass criteria:	<p>Mating force</p> <p>5 P Initial: 30 N MAX. 30cycles: 30 N MAX.</p> <p>10 P Initial: 30 N MAX. 30cycles: 30 N MAX.</p> <p>12 P Initial: 30 N MAX. 30cycles: 30 N MAX.</p> <p>Unmating force</p> <p>5 P Initial: 5 N MIN. 30cycles: 3 N MIN.</p> <p>10 P Initial: 5 N MIN. 30cycles: 3 N MIN.</p> <p>12 P Initial: 5 N MIN. 30cycles: 3 N MIN.</p>

2. Durability	
Reference standard:	-
Test conditions:	Solder the receptacle connector to the test board, then place the board and plug on the push-on/pull-off machine, and repeat mating and unmating 30cycles at a speed 25 ± 3 mm/min. along the mating axis.
Pass criteria:	Contact resistance: Shall meet 4.1.1

3. Cable retention force	
Reference standard:	-
Test conditions:	Place the plug connector on the push-on/pull-off machine and then apply force on the cable along the direction at a speed 25 ± 3 mm/min. Measure the force when the cable dislodges the plug connector.
Pass criteria:	5P: 2.45 N MIN. 10P: 4.90 N MIN. 12P: 5.88 N MIN.

4. Vibration	
Reference standard:	MIL-STD-202 G, Method 201
Test conditions:	<p>Solder the receptacle connector to the test board, then mate plug connector, and place them on the vibrator. Then apply the following vibration. During the testing, run 100mA DC to check electrical discontinuity.</p> <p>Frequency: 10Hz→55Hz→10Hz/approx. 1min.</p> <p>Directions: 3 mutually perpendicular direction.</p> <p>Total Amplitude: 1.52mm</p> <p>Sweep duration: 2 hours for each direction, a total of 6 hours.</p>
Pass criteria:	<p>Contact resistance: Shall meet 4.1.1.</p> <p>Electrical discontinuity: No electrical discontinuity greater than 1μs shall occur.</p> <p>Appearance: No abnormality adversely affecting the performance shall occur.</p>

4.3. Environmental Performance

4. Humidity(Cycling)

Reference standard: MIL-STD-202 G, Method 106.

Test conditions: Solder the receptacle connector to the test board, then mate plug connector, and expose them to the following environment.

Temperature: 298[263]~338K (25[-10]~65°C)

Humidity: 90~98%RH

Duration: 10cycles (240hours)

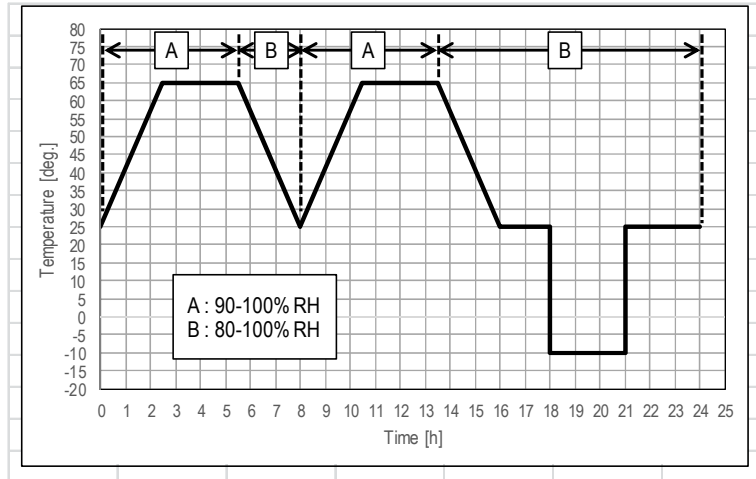

Pass criteria: Contact resistance: Shall meet 4.1.1.
Insulation resistance: Shall meet 4.1.2.
Dielectric withstanding voltage: Shall meet 4.1.3.
Appearance: No abnormality adversely affecting the performance shall occur.

5. Salt water spray

Reference standard: -

Test conditions: Solder the receptacle connector to the test board, then mate plug connector, and expose them to the following environment.

Temperature: 308±2K (35±2°C)

Salt water density: 5±1% [by weight]

Duration: 48 hours

Pass criteria: Contact resistance: Shall meet 4.1.1.
Appearance: No abnormality adversely affecting the performance shall occur.

6. H₂S gas

Reference standard: -

Test conditions: Solder the receptacle connector to the test board, then mate plug connector, and expose them to the following environment.

Temperature: 313±2K (40±2°C)

Relative humidity: 80±5%RH

Gas: H₂S 3±1ppm

Duration: 48 hours

Pass criteria: Contact resistance: Shall meet 4.1.1.
Appearance: No abnormality adversely affecting the performance shall occur.

4.4. Others

1. Solder ability

Reference standard: -

Test conditions: Dip the solder tine of the contact in the solder bath at $518 \pm 5K$ ($245 \pm 5^\circ C$) for 5 ± 0.5 seconds after immersing the tine in the flux of RMA or R type for 5 to 10 seconds.

Pass criteria: More than 95% of the dipped surface shall be evenly wet.

2. Soldering heat resistance

Reference standard: -

Test conditions: Reflow temperature as shown in Fig.2.
The number of times of Reflow is within 2. Nitrogen reflow cannot correspond.

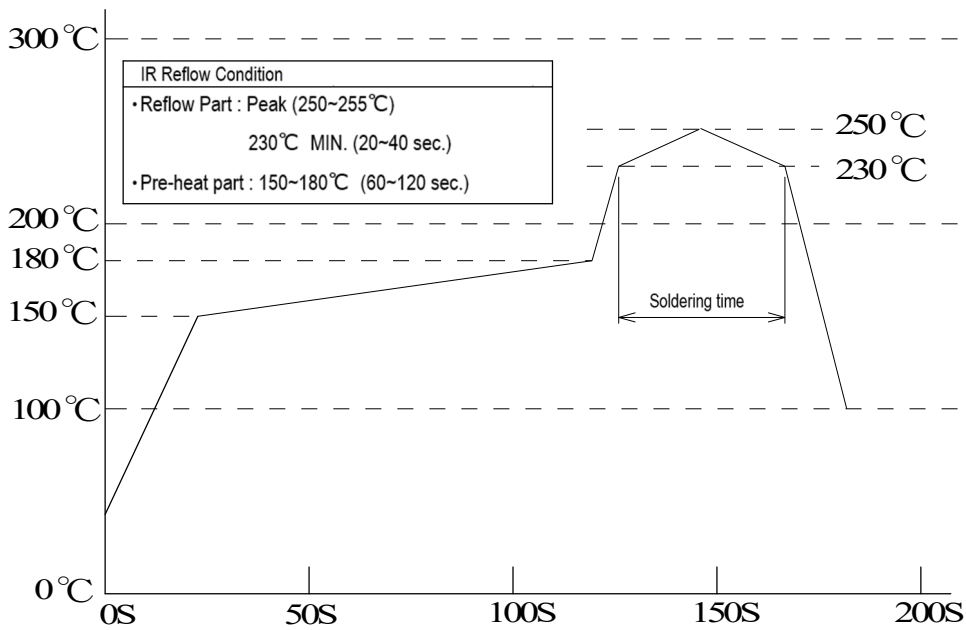

Fig.2

Pass criteria: No deformation nor defects adversely affecting the performance occur.

4.5 Test Sequence and Specimen Quantity

Table 1 Test Sequence and Sample Quantity

Test Item	Group											
	A	B	C	D	E	F	G	H	J	K	L	
Contact Resistance	2,6	1,3,5	1,5	1,3	1,3	1,5	1,3	1,3				
Insulation Resistance			2,6		2,6	2,6						
D. W. Voltage			3,7		3,7	3,7						
Temperature rising											1	
Mating Force	1,5											
Un-mating Force	3,7											
Durability	4											
Cable Retention Force	8											
Vibration		2										
Shock		4										
Thermal Shock			4									
High Temperature Life				2								
Humidity (Steady State)					4							
Humidity (Cycling)						4						
Salt Water Spray							2					
H2S Gas								2				
Solder ability									1			
Soldering Heat Resistance										1		
Specimen Quantity.	5 pcs.	5 pcs.	5 pcs.	5 pcs.	5 pcs.	5 pcs.	5 pcs.	5 pcs.	5 pcs.	10 pcs.	10 pcs.	5 Pcs.

※Numbers indicate sequence in which tests are performed.

5. Recommended Metal Mask

Recommended thickness of METAL MASK : $t=0.08$

Refer to drawing for the recommended metal mask thickness and opening dimension.

6. Precautions for Handling Cable Connectors

Refer to instruction manual: HIM-18037 for the handling of CABLINE-UY.