

CABLINE[®]-UX II Connector

Part No. Plug: 20531 Receptacle: 20533

Product Specification

Qualification Test Report No. TR-10051

8	S22098	March 8, 2022	E.Tanaka	A.Koyanagi	H.Ikari
7	S22064	February 10, 2022	A.Koyanagi	T.Tanigawa	H.Ikari
6	S19430	July 8, 2019	A.Koyanagi	T.Kurachi	H.Ikari
5	S17537	September 21, 2017	R.Hoshino	S.Kawamura	M.Takemoto
Rev.	ECN	Date	Prepared by	Checked by	Approved by

1. Scope

This product specification defines the test conditions and the performances of the CABLINE-UX II Connector, a wire-to-board connector of 0.25 mm contact pitch.

2. Product Name and Parts No.

2.1 Product Name

CABLINE-UX II

2.2 Parts No.

Plug: CABLINE-UX II PLUG CABLE ASS'Y (Part No. 20531-0**T-*2)
• CABLINE-UX II PLUG HOUSING ASS'Y (Part No. 20532-0**T-*2)
• CABLINE-UX II PLUG METAL COVER (Part No. 2799-0**1)
Receptacle: CABLINE-UX II RECEPTACLE ASS'Y (Part No.20533-0**E-**)

3. Rating

3.1 Applicable Cable

AWG#39, 44, 46

3.2 Operating Conditions

Amperage:

Phosphor Bronze (RECEPTACLE: 20533-0**E, PLUG: 20531-0**T-02)
0.50 AAC/DC [AWG#39] (per contact pin / up to 6 contacts)
0.15 AAC/DC [AWG#44] (per contact pin)
0.10 AAC/DC [AWG#46] (per contact pin)
Corson Alloy (RECEPTACLE: 20533-0**E-01, PLUG: 20531-0**T-12)
0.50 AAC/DC [AWG#39] (per contact pin / up to 8 contacts)
0.19 AAC/DC [AWG#44] (per contact pin)
0.14 AAC/DC [AWG#46] (per contact pin)

Voltage: 50V AC (per contact pin)

Operating temperature: 233 to 358K(-40°C to 85°C) (Containing temperature rise by current)

Operating humidity: 75% max

3.3 Storage Conditions

Storage temperature: 273 to 313K(0°C to 40°C)

Storage humidity: 75% max. (Non-condensing)

4. Test and Performance

Test Condition

Unless otherwise specified, all tests and measurements shall be performed under the following conditions in accordance with MIL-STD-202.

Temperature: 288K to 308K(15°C to 35°C)

Pressure: 866hPa to 1066hPa(650mmHg to 800mmHg)

Relative humidity: 45 to 75% R.H.

4.1. Electrical Performance

1. Contact resistance	
Reference standard:	MIL-STD-202-307
Test conditions:	Solder the receptacle connector to the test board and mate the plug connector together, then apply 20mV MAX. DC open circuit voltage and 10mA MAX. DC closed circuit current. Measure the contact resistance of signal and GROUND at the section shown in Fig.1 by the four terminal methods.
<p>Fig.1</p>	
Pass criteria:	<p>Signal Contact Initial: 450 mΩMAX.(AWG#39), 1,080 mΩMAX.(AWG#44), 1,880 mΩMAX.(AWG#46) After testing: ΔR40 mΩ MAX. Initial contains the following conductor resistance of a cable 100 mm. 370 mΩMAX.(AWG#39), 1,000 mΩ(AWG#44), 1,800 mΩ(AWG#46)</p> <p>Ground contact Initial: 100 mΩ MAX. After testing: ΔR 40 mΩ MAX.</p>
2. Insulation resistance	
Reference standard:	MIL-STD-202-302
Test conditions:	Mate the plug and receptacle connector together, and then apply DC 100 V between the inner contact and the ground contact.
Pass criteria:	Initial: 100 MΩ MIN. After testing: 100 MΩ MIN.
3. Dielectric withstanding voltage	
Reference standard:	MIL-STD-202-301
Test conditions:	Mate the receptacle and plug connector together, then apply AC 100V(rms) between the neighboring contacts for a minute.
Pass criteria:	No abnormalities such as creeping discharge, flashover, insulator breakdown occur.
4. Temperature rising	
Reference standard:	-
Test conditions:	Mate the plug and receptacle connector together, and apply rating current per contact pin. Measure delta T over ambient.
Pass criteria:	Over ambient Δ T30 °C MAX.

4.2. Mechanical Performance

1. Mating force and Un-mating force		
Reference standard:	-	
Test conditions:	Solder the receptacle connector to the test board, then place the board and plug on push-on/pull-off machine. Repeat mating/unmating 20 cycles at a speed 25 ± 3 mm/min. along the mating axis. Measure the mating and unmating force at the initial and after 20cycles.	
Pass criteria:	Mating force	Un-mating force
	30 P: 26.4 N MAX.	30 P: 1.5 N MIN.
	34 P: 27.6 N MAX.	34 P: 1.9 N MIN.
	40 P: 29.4 N MAX.	40 P: 2.5 N MIN.
	50 P: 32.4 N MAX.	50 P: 3.5 N MIN.

2. Durability	
Reference standard:	-
Test conditions:	Solder the receptacle connector to the test board, then place the board and plug on the push-on/pull-off machine, and repeat mating and unmating 20cycles at a speed 25 ± 3 mm/min. along the mating axis.
Pass criteria:	Contact resistance: Shall meet 4.1.1

3. Contact retention force	
Reference standard:	-
Test conditions:	Place the connector on the push-on/pull-off machine, then apply force to the contact from opposite direction of the contact insertion at a speed of 25 ± 3 mm/min. Measure the force when the contact dislodges from the connector.
Pass criteria:	Plug contact retention force: 0.5N MIN. Receptacle contact retention force: 0.2N MIN.

4. Cable retention force	
Reference standard:	-
Test conditions:	Place the plug connector on the push-on/pull-off machine and pull the cable along the cable axis at a speed 25 ± 3 mm/min. Measure the force when the discontinuity occurs.
Pass criteria:	30P: 15.0 N MIN. 34P: 17.0 N MIN. 40P: 20.0 N MIN. 50P: 25.0 N MIN.

5. Vibration	
Reference standard:	MIL-STD-202-201
Test conditions:	Solder the receptacle connector to the test board, then mate plug connector, and place them on the vibrator. Then apply the following vibration. During the testing, run 100mA DC to check electrical discontinuity. Frequency: 10Hz→55Hz→10Hz/approx. 1min. Directions: 3 mutually perpendicular directions. Total Amplitude: 1.52mm Sweep duration: 2 hours for each direction, a total of 6 hours.
Pass criteria:	Contact resistance: Shall meet 4.1.1. Electrical discontinuity: No electrical discontinuity greater than 1μs shall occur. Appearance: No abnormality adversely affecting the performance shall occur.

6. Shock	
Reference standard:	MIL-STD-202-213, Test condition A.
Test conditions:	Solder the receptacle connector to the test board, then mate plug connector, and place them on the shock machine. Then apply the following shock. MAX.G: 50G Duration: 11msec Wave Form: Half Sinusoidal Directions: 6 mutually perpendicular direction Cycle: 3 cycles each direction
Pass criteria:	Contact resistance: Shall meet 4.1.1. Electrical discontinuity: No electrical discontinuity greater than 1 μ s shall occur. Appearance: No abnormality adversely affecting the performance shall occur.

4.3. Environmental Performance

1. Thermal shock	
Reference standard:	MIL-STD-202-107, Test condition A.
Test conditions:	Solder the receptacle connector to the test board, then mate plug connector, and expose them to the following environment. Temperature: 218K(-55°C),30min.→358K(85°C),30min. Transition time: 5min. MAX. Cycle: 5 cycles
Pass criteria:	Contact resistance: Shall meet 4.1.1. Insulation resistance: Shall meet 4.1.2. Dielectric withstanding voltage: Shall meet 4.1.3. Appearance: No abnormality adversely affecting the performance shall occur.

2. High temperature life	
Reference standard:	MIL-STD-202-108, Test condition A.
Test conditions:	Solder the receptacle connector to the test board, then mate plug connector, and expose them to the following environment. Temperature: 358 \pm 2K (85 \pm 2°C) Duration: 96 hours
Pass criteria:	Contact resistance: Shall meet 4.1.1. Contact retention force: Shall meet 4.2.3. Appearance: No abnormality adversely affecting the performance shall occur.

3. Humidity (Steady state)	
Reference standard:	MIL-STD-202-103, Test condition B.
Test conditions:	Solder the receptacle connector to the test board, then mate plug connector, and expose them to the following environment. Temperature: 313 \pm 2K (40 \pm 2°C) Humidity: 90~95%RH Duration: 96 hours
Pass criteria:	Contact resistance: Shall meet 4.1.1. Insulation resistance: Shall meet 4.1.2. Dielectric withstanding voltage: Shall meet 4.1.3. Appearance: No abnormality adversely affecting the performance shall occur.

4. Humidity (Cycling)

Reference standard: MIL-STD-202-106.

Test conditions: Solder the receptacle connector to the test board, then mate plug connector, and expose them to the following environment.
 Temperature: 298[263]~338K (25[-10]~65°C)
 Humidity: 90[80]~100%RH
 Duration: 10cycles (240hours)

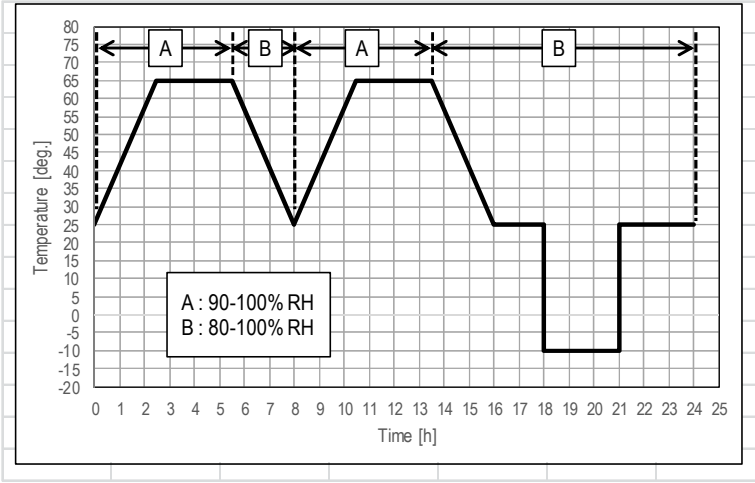

Pass criteria: Contact resistance: Shall meet 4.1.1.
 Insulation resistance: Shall meet 4.1.2.
 Dielectric withstanding voltage: Shall meet 4.1.3.
 Appearance: No abnormality adversely affecting the performance shall occur.

5. Saltwater spray

Reference standard: MIL-STD-202-101, Test condition B.

Test conditions: Solder the receptacle connector to the test board, then mate plug connector, and expose them to the following environment.
 Temperature: 308±2K (35±2°C)
 Saltwater density: 5±1% [by weight]
 Duration: 48 hours

Pass criteria: Contact resistance: Shall meet 4.1.1.
 Appearance: No abnormality adversely affecting the performance shall occur.

6. H₂S gas

Reference standard: -

Test conditions: Solder the receptacle connector to the test board, then mate plug connector, and expose them to the following environment.
 Temperature: 313±2K (40±2°C)
 Relative humidity: 80±5%RH
 Gas: H₂S 3±1ppm
 Duration: 48 hours

Pass criteria: Contact resistance: Shall meet 4.1.1.
 Appearance: No abnormality adversely affecting the performance shall occur.

4.4. Others

1. Solderability

Reference standard:	-
Test conditions:	Immerse the contact soldering part to flux of RMA or R type for 5 to 10 seconds, then dip the part into the solder bath of 518±5K (245±5°C) for 5±0.5seconds.
Pass criteria:	More than 95% of the dipped surface shall be evenly wet.

2. Resistance to soldering heat

Reference standard:	-
Test conditions:	Reflow temperature: See Fig.2. Cycle: 2

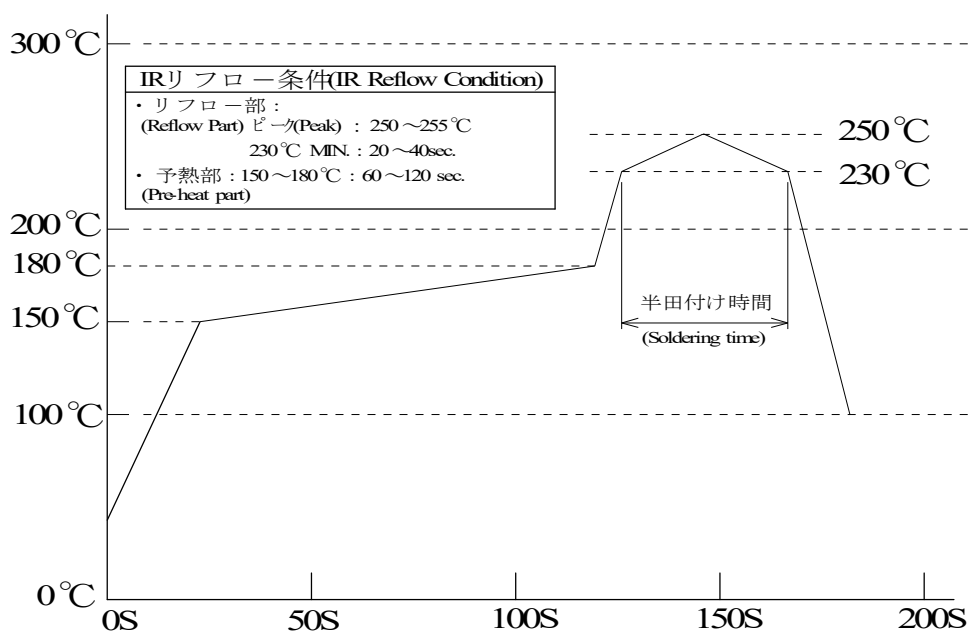

Fig.2

Pass criteria:	No deformation nor defect adversely affecting the performance occur.
----------------	--

4.5 Test Sequence and Specimen Quantity

Table.1 Test Sequence and Sample Quantity

Test Item	Group											
	A	B	C	D	E	F	G	H	J	K	L	M
Contact resistance	2,6		1,3,5	1,5	1,3	1,5	1,5,7	1,3	1,3			
Insulation resistance				2,6		2,6	2,8					
Dielectric withstanding voltage				3,7		3,7	3,9					
Temperature rising												1
Mating force	1,5											
Unmating force	3,7											
Durability	4						4					
Contact retention force		1,3										
Cable retention force	8											
Vibration			2									
Shock			4									
Thermal shock				4								
High temperature life		2			2							
Humidity (Steady State)						4						
Humidity (Cycling)							6					
Saltwater spray								2				
H ₂ S gas									2			
Solder ability										1		
Soldering heat resistance											1	
Specimen quantity.	5 pcs.	20 pos.	5 pcs.	5 pcs.	5 pcs.	5 pcs.	5 pcs.	5 pcs.	5 pcs.	10 pcs.	10 pcs.	5 pcs.

※Numbers indicate test sequences.

5. Recommended Metal Mask

Refer to drawing for the recommended metal mask thickness and opening dimension.

6. Precautions for Handling Cable Connectors

- Do not pull up the cable to withdraw the plug connector as shown in Fig. 3.
- “Withdrawal JIG” must be lifted vertically from PCB surface.
- Do not hold the plug connector during withdrawal of the plug connector.
- In case you have to withdraw the plug connector without JIG, please use your nail as JIG and withdraw the connector in accordance with the method using “Withdrawal JIG”.

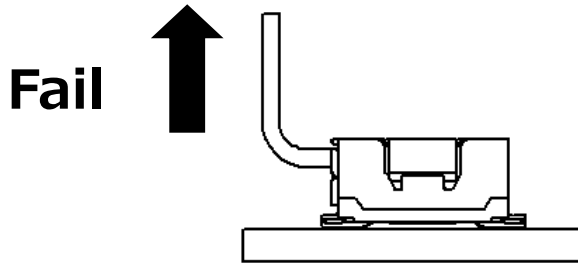

Fig. 3

- Handle the cable connector carefully in cable harnessing work so that pulling force is NOT applied to specific cables.
- Be careful so that pulling force and/or repeated bending force is NOT applied to the cable attachment part of a cable connector.

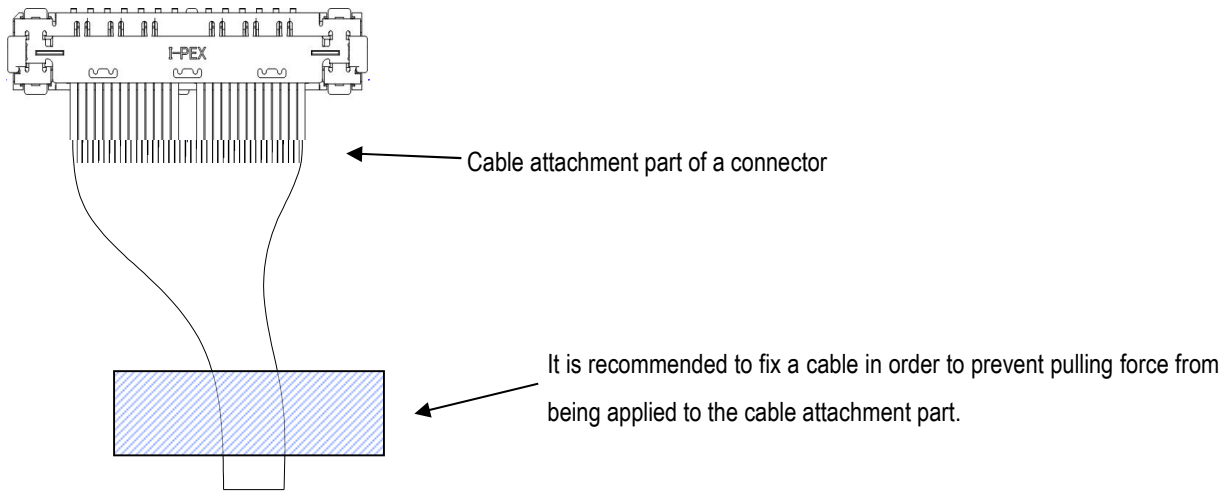

Fig. 4

- In the case of figure 5, it has possibility to damage to the housing and come off from receptacle connector. Especially when operator give continuous force to the direction (black arrow), the tendency become higher. So please take care of handling of harness.

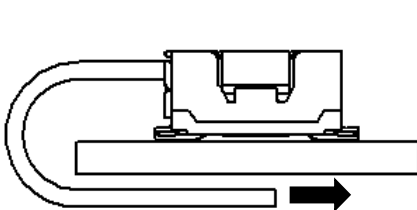

Fig. 5-1

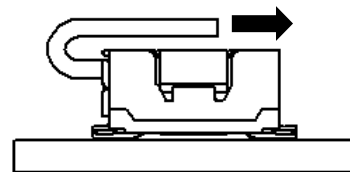

Fig. 5-2

- You may put a stopper above the mated cable connector to prevent it from coming out. Use recommended that the load to be applied to a stopper must be connector whose top surface under the following condition.

Table 2 Press load

Pos.	Load (N)	Upper area (mm ²)
30P	3.0 N MAX.	23.2 mm ²
34P	3.4 N MAX.	25.2 mm ²
40P	4.0 N MAX.	28.2 mm ²
50P	5.0 N MAX.	33.2 mm ²

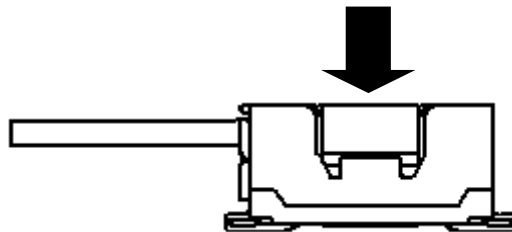

Fig. 6 Press load for mated connector