

CABLIN[®]-UA II Connector

Part No. Plug: 20496-***-** Receptacle: 20498-***E-**

Product Specification

Qualification Test Report No. TR-09032

14	S19429	July 8, 2019	S.Yamaguchi	T.Kurachi	H.Ikari
13	S18094	January 29, 2018	R.Hoshino	K.Tanaka	M.Takemoto
12	S17544	July 27, 2017	R.Hoshino	K.Tanaka	M.Takemoto
11	S17201	March 16, 2017	R.Hoshino	H.Tagomori	M.Takemoto
Rev.	ECN	Date	Prepared by	Checked by	Approved by

CABLINE®-UA II Connector Product Specification

1. 適応範囲／Scope

本規格は、コンタクトピッチ 0.3 mm の基板対ワイヤーコネクタである CABLINE-UA II コネクタの性能と試験条件について規定する。

This Product Specification defines the test conditions and the performances of the CABLINE-UA II Connector, a wire-to-board connector of 0.3 mm contact pitch.

2. 製品名称及び製品型番／Product Name and Parts No.

2.1 製品名称／Product Name

CABLINE-UA II

2.2 製品型番／Parts No.

- (1) CABLINE-UA II PLUG CABLE ASS'Y: 20496-***-**
 - ・CABLINE-UA II PLUG HOUSING ASS'Y: 20497-***T-**
 - ・CABLINE-UA II PLUG METAL COVER: 2679-0**-*0
- (2) CABLINE-UA II RECEPTACLE ASS'Y: 20498-***E-**

3. 定格／Rating

3.1 適応ケーブル／Applicable Cable

Micro Coax …AWG#[46、44、42]

Discrete …AWG#[39]

3.2 使用条件／Operating Conditions

電流／Amperage: 0.15 A AC/DC [AWG#46] (per contact)
0.19 A AC/DC [AWG#44] (per contact)
0.20 A AC/DC [AWG#42] (per contact)
0.50 A AC/DC [AWG#39] (per contact/Up to 10 Contacts)

電圧／Voltage: 50V AC (per a contact)

使用温度／Operating temperature: 233~358 K (-40 °C~85 °C)

(通電による温度上昇含む／Containing temperature rise by current)

使用湿度／Operating humidity: 85% Max.

3.3 保管条件／Storage Conditions

保管温度／Storage temperature: 273~313 K (0 °C~40 °C)

保管湿度／Storage humidity: 10~75%RH (結露無き事／Non-condensing)

4. 試験及び性能／Test and Performance

試験条件／Test Condition

本試験の初期とは、出荷時の状態の事である。

特に指定のない限り、測定と試験は、MIL-STD-202 Fに基づき以下の条件で行う。

This initial test is equal to its shipping condition and unless otherwise specified, all tests and measurements shall be performed under the following conditions in accordance with MIL-STD-202 F.

温度／Temperature… 288 K~308 K (15 °C~35 °C)

気圧／Pressure… 866 hPa~1,066 hPa (650 mmHg~800 mmHg)

相対湿度／Relative humidity… 45~75%RH

4.1.電氣的性能 / Electrical Performance

1. 接触抵抗 Contact resistance

Reference standard: MIL-STD-202, Method 307

試験条件: テスト基板にレセプタクルコネクタを半田付けし、プラグコネクタを嵌合させ、開回路電圧 20 mV DC 以下、短絡電流 10 mA DC 以下で 4 端子法にて芯線及びシールド線の図 1 に示す区間の接触抵抗を測定する。

Test conditions: Solder the receptacle connector to the test board and mate the plug connector together, then measure the contact resistance as shown in Fig.1 by the four terminal methods. Apply the low level condition of 20 mV Max. DC for the open circuit voltage and 10 mA Max. DC for the closed circuit current.

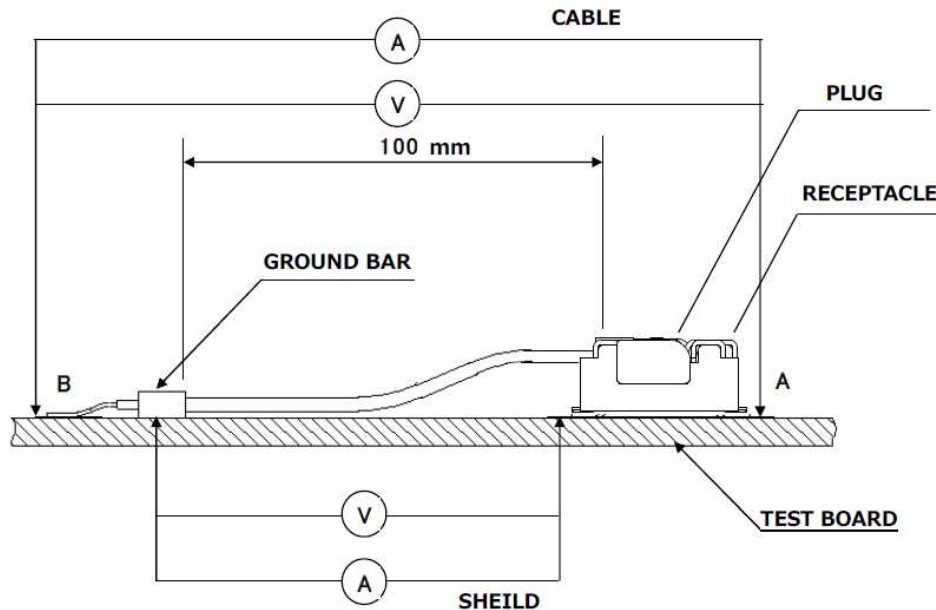

Fig.1

<p>合格基準: コンタクト</p> <p>初期: 450 mΩMAX.(AWG#39) 700 mΩMAX.(AWG#42) 1,080 mΩMAX.(AWG#44) 1,880 mΩMAX.(AWG#46)</p> <p>試験後: ΔR 40mΩ MAX グランドシールド 初期: 50 mΩ MAX. 試験後: ΔR40mΩ MAX.</p> <p>Pass criteria: Contact</p> <p>Initial: 450 mΩMAX.(AWG#39) 700 mΩMAX.(AWG#42) 1,080 mΩMAX.(AWG#44) 1,880 mΩMAX.(AWG#46)</p> <p>After testing: ΔR 40mΩ MAX. Ground Shell Initial: 50 mΩ MAX. After testing: ΔR40mΩ MAX.</p>	<p>初期値は、以下に示すケーブル 100mm の導体抵抗を含む。</p> <p>370 mΩMAX.(AWG#39) 620 mΩMAX. (AWG#42) 1,000 mΩMAX. (AWG#44) 1,800 mΩMAX. (AWG#46)</p> <p>Initial contains the following conductor resistance of a cable 100mm.</p> <p>370 mΩMAX.(AWG#39) 620 mΩMAX. (AWG#42) 1,000 mΩMAX. (AWG#44) 1,800 mΩMAX. (AWG#46)</p>
---	--

4.1.電氣的性能／Electrical Performance

2. 絶縁抵抗 Insulation resistance	
Reference standard:	MIL-STD-202, Method 302
試験条件:	リセプタクル及びプラグコネクタを嵌合させた状態で、中心導体と外部導体の間に DC 250 V を印加し、測定する。
Test conditions:	Mate the plug and receptacle connector together, and then apply DC 250 V between the inner contact and the ground contact.
合格基準:	初期: 100 MΩ MIN. 試験後: 100 MΩ MIN.
Pass criteria:	Initial: 100 MΩ MIN. After testing: 100 MΩ MIN.

3. 耐電圧 Dielectric withstanding voltage	
Reference standard:	MIL-STD-202, Method 301
試験条件:	リセプタクル及びプラグコネクタを嵌合させ、隣接する端子間に AC 100 V (実効値) を一分間印加する。
Test conditions:	Mate the receptacle and plug connector together, then apply AC 100 V (rms) between the neighboring contacts for a minute.
合格基準:	沿面放電、空中放電、絶縁破壊等の異常無き事。
Pass criteria:	No creeping discharge, flashover, insulator breakdown occur.

4. 温度上昇 Temperature rising	
Reference standard:	-
試験条件:	リセプタクル及びプラグコネクタを互いに嵌合させ、各コネクタに定格電流を通電、周囲温度上昇を測定する。
Test conditions:	Mate the plug and receptacle connector together and then apply rating current per contact.
合格基準:	温度上昇 ΔT30 °C MAX.
Pass criteria:	Over ambient ΔT30 °C MAX.

4.2.機械的性能／Mechanical Performance

1. 挿抜力 Mating force and Un-mating force	
Reference standard:	-
試験条件:	テスト基板にリセプタクルを半田付けする。その後、試料を挿抜試験機に取り付け、嵌合軸に平行に毎分 25±3 mm の速度で、初期及び 20 回目の挿入抜去力を測定する。
Test conditions:	Solder the receptacle connector to the test board. Place the test board and plug on push-on/pull-off machine. Measure the mating and un-mating force of initial and after mating/un-mating 20 cycles at a speed 25±3 mm/min. along the mating axis.
合格基準:	挿入力 26 P 28.0 N MAX. 32 P 34.5 N MAX. 40 P 40.0 N MAX. 50 P 50.0 N MAX. 抜去力 26 P 3.0 N MIN. 32 P 3.0 N MIN. 40 P 3.0 N MIN. 50 P 3.0 N MIN.
Pass criteria:	Mating force 26 P Initial: 28.0 N MAX. 32 P Initial: 34.5 N MAX. 40 P Initial: 40.0 N MAX. 50 P Initial: 50.0 N MAX. Un-mating force 26 P Initial: 3.0 N MIN. 32 P Initial: 3.0 N MIN. 40 P Initial: 3.0 N MIN. 50 P Initial: 3.0 N MIN.

2. 耐久性 Durability	
Reference standard:	-
試験条件:	テスト基板にリセプタクルを半田付けする。その後、試料を挿抜試験機に取り付け、嵌合軸に平行に毎分 25±3 mm の速度で、20 回挿入抜去を行う。
Test conditions:	Solder the receptacle connector to the test board. Place the test board and plug on push-on/pull-off machine. Repeat mating and un-mating 20 cycles at a speed 25±3 mm/min. along the mating axis.
合格基準:	接触抵抗: 4.1.1 を満足する事。
Pass criteria:	Contact resistance: Shall meet 4.1.1

3. 端子保持力 Contact retention force	
Reference standard:	-
試験条件:	コネクタを挿抜試験機に取り付け、毎分 25±3 mm の速度で端子の軸に沿って、端子に圧入と逆方向の荷重を加え、端子がコネクタより抜ける時の荷重を測定する。
Test conditions:	Place the connector on the push-on/pull-off machine. Then apply force on the contact head and push the contact along the opposite direction of the contact insertion at a speed of 25±3 mm/min. Measure the force when the contact dislodges the connector.
合格基準:	プラグ端子保持力: 0.5 N MIN. リセプタクル端子保持力: 0.2 N MIN.
Pass criteria:	Plug contact retention force: 0.5 N MIN. Receptacle contact retention force: 0.2 N MIN.

4.3.耐環境性能/Environmental Performance

1. 熱衝撃 Thermal shock	
Reference standard:	MIL-STD-202, Method 107, Condition A.
試験条件:	テスト基板にリセプタクルコネクタを半田付けし、プラグコネクタと嵌合させ、以下の環境条件に暴露する。 温度: 218K (-55 °C), 30分→358 K(85 °C), 30分 移動時間: 5分 Max. 回数: 5サイクル
Test conditions:	Solder the receptacle connector to the test board. Then mate the plug connector, and expose them to the following environment. Temperature: 218 K (-55 °C), 30 minutes→358 K (85 °C), 30 minutes Transition time: 5 minutes Max. No. of cycles: 5 cycles
合格基準:	接触抵抗: 4.1.1.を満足する事。 絶縁抵抗: 4.1.2.を満足する事。 耐電圧: 4.1.3.を満足する事。 外観: 異常無き事。
Pass criteria:	Contact resistance: Shall meet 4.1.1. Insulation resistance: Shall meet 4.1.2. Dielectric withstanding voltage: Shall meet 4.1.3. Appearance: No abnormality.

2. 高温寿命 High temperature life	
Reference standard:	MIL-STD-202, Method 108, Condition B.
試験条件:	テスト基板にリセプタクルコネクタを半田付けし、プラグコネクタと嵌合させ、以下の環境条件に暴露する。 温度: 358±2 K (85±2 °C) 期間: 250時間
Test conditions:	Solder the receptacle connector to the test board. Then mate the plug connector, and expose them to the following environment. Temperature: 358±2 K (85±2 °C) Duration: 250 hours
合格基準:	接触抵抗: 4.1.1.を満足する事。 端子保持力: 4.2.3.を満足する事。 外観: 異常無き事。
Pass criteria:	Contact resistance: Shall meet 4.1.1. Contact retention force: Shall meet 4.2.3. Appearance: No abnormality.

4.3.耐環境性能/Environmental Performance

3. 湿度(定常状態) Humidity(Steady state)	
Reference standard:	MIL-STD-202, Method 103, Condition A.
試験条件:	テスト基板にリセプタクルコネクタを半田付けし、プラグコネクタと嵌合させ、以下の環境条件に暴露する。 温度: 313±2 K (40±2 °C) 湿度: 90~95%RH 期間: 240 時間
Test conditions:	Solder the receptacle connector to the test board. Then mate plug connector, and expose them to the following environment. Temperature: 313±2 K (40±2 °C) Humidity: 90~95%RH Duration: 240 hours
合格基準:	接触抵抗: 4.1.1.を満足する事。 絶縁抵抗: 4.1.2.を満足する事。 耐電圧: 4.1.3.を満足する事。 外観: 異常無き事。
Pass criteria:	Contact resistance: Shall meet 4.1.1. Insulation resistance: Shall meet 4.1.2. Dielectric withstanding voltage: Shall meet 4.1.3. Appearance: No abnormality.

4. 湿度(サイクリング) Humidity(Cycling)	
Reference standard:	MIL-STD-202, Method 106.
試験条件:	テスト基板にリセプタクルコネクタを半田付けし、プラグコネクタと嵌合させ、以下の環境条件に暴露する。 温度: 298[263]~338 K (25[-10]~65 °C) 湿度: 90~98%RH 期間: 10 サイクル (240 時間)
Test conditions:	Solder the receptacle connector to the test board. Then mate plug connector, and expose them to the following environment. Temperature: 298 [263]~338 K (25 [-10] to 65 °C) Humidity: 90~98%RH Duration: 10 cycles (240 hours)
合格基準:	接触抵抗: 4.1.1.を満足する事。 絶縁抵抗: 4.1.2.を満足する事。 耐電圧: 4.1.3.を満足する事。 外観: 異常無き事。
Pass criteria:	Contact resistance: Shall meet 4.1.1. Insulation resistance: Shall meet 4.1.2. Dielectric withstanding voltage: Shall meet 4.1.3. Appearance: No abnormality.

4.3.耐環境性能 / Environmental Performance

5. 塩水噴霧 Salt water spray	
Reference standard:	MIL-STD-202, Method 101, Condition B.
試験条件:	テスト基板にリセプタクルコネクタを半田付けし、プラグコネクタと嵌合させ、以下の環境条件に暴露する。 温度: 308±2 K (35±2 °C) 塩水濃度: 5±1% [重量比] 期間: 48 時間
Test conditions:	Solder the receptacle connector to the test board. Then mate plug connector, and expose them to the following environment. Temperature: 308±2 K (35±2 °C) Salt water density: 5±1% [by weight] Duration: 48 hours
合格基準:	接触抵抗: 4.1.1.を満足する事。 外観: 異常無き事。
Pass criteria:	Contact resistance: Shall meet 4.1.1. Appearance: No abnormality.

6. 硫化水素ガス H ₂ S gas	
Reference standard:	-
試験条件:	テスト基板にリセプタクルコネクタを半田付けし、プラグコネクタと嵌合させ、以下の環境条件に暴露する。 温度: 313±2 K (40±2 °C) 相対湿度: 80±5%RH ガス: H ₂ S 3±1 ppm 期間: 48 時間
Test conditions:	Solder the receptacle connector to the test board. Then mate plug connector, and expose them to the following environment. Temperature: 313±2 K (40±2 °C) Relative humidity: 80±5%RH Gas: H ₂ S 3±1 ppm Duration: 48 hours
合格基準:	接触抵抗: 4.1.1.を満足する事。 外観: 性能上有害な異常無き事。
Pass criteria:	Contact resistance: Shall meet 4.1.1. Appearance: Abnormality, affecting the performance adversely shall not occur.

4.4.その他/Others

1. 半田付け性 Solder ability	
Reference standard:	MIL-STD-202, Method 208.
試験条件:	端子の半田付け部を 518±5 K (245±5℃) の半田槽内に 5±0.5 秒間浸す。フラックスは、RMA 型
Test conditions:	または R 型を使用し、5～10 秒間浸漬するものとする。 Dip the solder tine of the contact in the solder bath at 518±5K (245±5 °C) for 5±0.5 seconds after immersing the tine in the flux of RMA or R type for 5 to 10 seconds.
合格基準:	浸した面線の 95%以上に半田がむらなく付着する事。
Pass criteria:	More than 95% of the dipped surface shall be wet evenly.

2. 半田耐熱性 Soldering heat resistance	
Reference standard:	-
試験条件:	リフロー温度プロファイルは図 2 を参照。リフロー回数は 2 回以内。 ※N2 リフロー実装を行う場合は、事前に実装によるリフロー条件の確認をお願いします。
Test conditions:	Reflow temperature as shown in Fig.2. The number of times of Reflow is within 2. *Reflow conditions must be pretested before N2 reflow soldering.
Fig.2	
合格基準:	機能を損なう変形及び欠陥の無き事。
Pass criteria:	Abnormality, affecting the performance adversely shall not occur.

4.5 試験順序と試料数/Test Sequence and Specimen Quantity

Table 1 試験順序と試料数/Test Sequence and Sample Quantity

試験項目 Test Item	グループ/Group											
	A	B	C	D	E	F	G	H	I	J	K	L
接触抵抗 Contact Resistance	2,6		1,3,5	1,5	1,3	1,5	1,5,7	1,3	1,3			
絶縁抵抗 Insulation Resistance				2,6		2,6	2,8					
耐電圧 D. W. Voltage				3,7		3,7	3,9					
温度上昇 Temperature rising												1
挿入力 Mating Force	1,5											
抜去力 Un-mating Force	3,7											
耐久性 Durability	4						4 (10cycles)					
端子保持力 Contact Retention Force		1										
ケーブル保持力 Cable Retention Force	8											
耐振動性 Vibration			2									
耐衝撃性 Shock			4									
熱衝撃 Thermal Shock				4								
高温寿命 High Temperature Life					2							
湿度 (定常状態) Humidity (Steady State)						4						
湿度 (サイクリング) Humidity (Cycling)							6					
塩水噴霧 Salt Water Spray								2				
硫化水素ガス H2S Gas									2			
半田付け性 Solder ability										1		
半田耐熱性 Soldering Heat Resistance											1	
試料数 Specimen Quantity.	5 pcs.	20 pos.	5 pcs.	5 pcs.	5 pcs.	5 pcs.	5 pcs.	5 pcs.	5 pcs.	10 pcs.	10 pcs.	5 pcs.

※グループ表中の番号は、試験順序を示す。/Numbers indicate sequence in which tests are performed.

5. 推奨メタルマスク Recommended Metal Mask

推奨マスク厚 / Recommended Thickness of Metal Mask : $t=0.12$

Part No.	Pos.	A	B	C
20498-*26E-**	26	10.8	8.1	3.6
20498-*32E-**	32	12.6	9.9	4.5
20498-*40E-**	40	15.0	12.3	5.7
20498-*50E-**	50	18.0	15.3	7.2

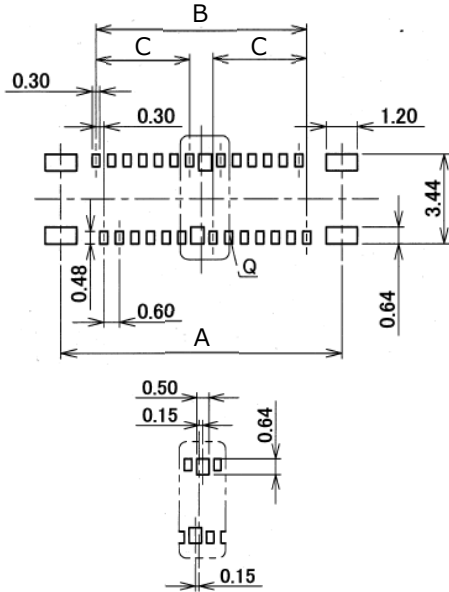

DETAIL Q (26P, 50P)

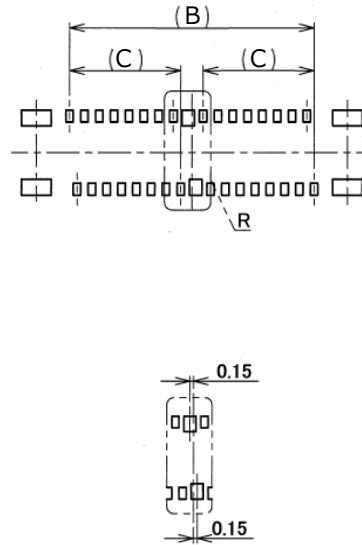

DETAIL R (32P, 40P)

Recommended Metal Mask

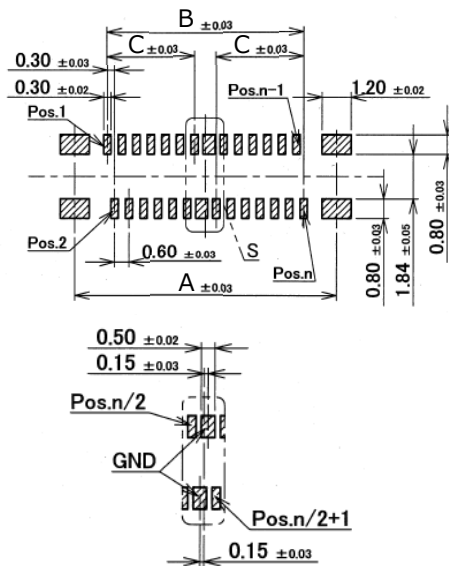

DETAIL S (26P, 50P)

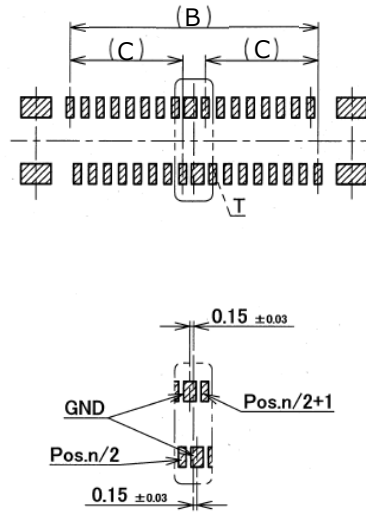

DETAIL T (32P, 40P)

Recommended Footprint Pattern (Mount Side)

CABLIN[®]-UA II Connector Product Specification

6. コネクタ取り扱いの注意 Precautions for Handling Cable Connectors

- ・図 3 のようにケーブルを引っ張り上げ、コネクタの抜去を行わないでください。
- ・治具は必ず基板と垂直に引き上げてください。
- ・プラグコネクタを抑えながらの抜去は禁止。
- ・治具を使用せず手（爪）で抜去しなければならない場合は、治具と同様の方法にて抜去してください。

- ・Do not pull up the cable to withdraw the plug connector as shown in Fig. 3.
- ・“Withdrawal JIG” must be lifted vertically from PCB surface.
- ・Do not hold the plug connector during withdrawal of the plug connector.
- ・In case you have to withdraw the plug connector without JIG, please use your nail as JIG and withdraw the connector in accordance with the method using “Withdrawal JIG”.

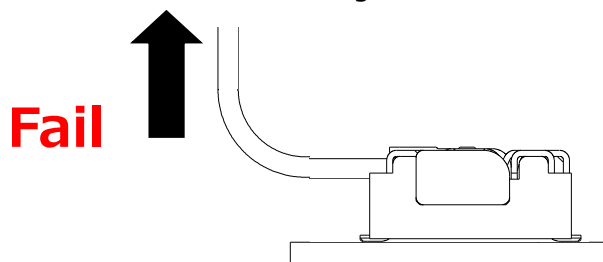

Fig.3

- ・ケーブルコネクタの取り回しの際には特定のケーブルに引っ張り力が集中しないように配慮ください。
- ・コネクタのケーブル取り付け部に引っ張り力及び繰り返し変位が加わらないように配慮ください。
- ・Handle the cable connector carefully in cable harnessing work so that pulling force is NOT applied to specific cables.
- ・Pulling force and/or repeated bending force is NOT applied to the cable attachment part of a cable connector.

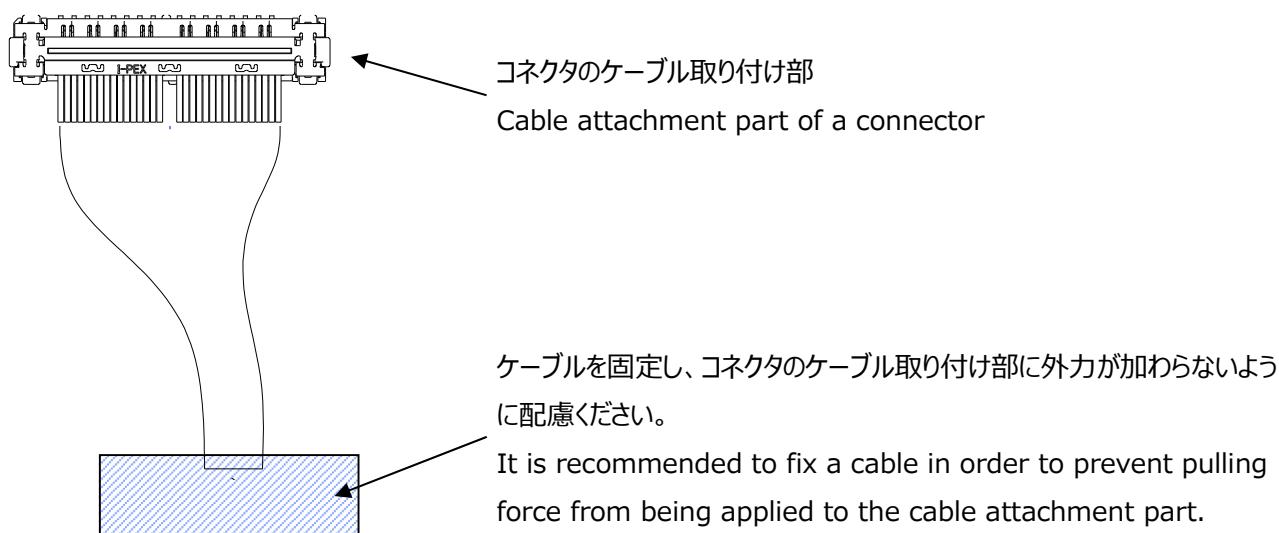

Fig. 4

- ・図 5 のように、矢印方向に常に力が加わるようなケーブルの引き直しを行うと、嵌合外れやコネクタの破損等の恐れがありますので、

ご注意願います。

- In the case of fig. 5, there is possibility to damage the housing and come off from receptacle connector. Especially when the operators apply force of the direction (black arrow) continuous, the tendency becomes higher. So please take care of handling of harness.

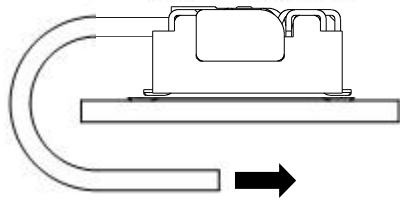

Fig. 5-1

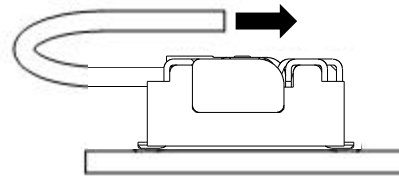

Fig. 5-2

- 嵌合状態のコネクタ抜け止め荷重（筐体で押さえる荷重）につきましては、下記条件でコネクタ上面全体を押えるようにしてください。
- You may put a stopper above the mated cable connector to prevent coming out. Use recommended loads to apply on the connector, and the stopper must apply on the top surface of connectors as shown as Fig.6.

Table 2 Press Load

極数: pos.	荷重: load (N)	上面の面積: Upper area (mm ²)
26P	2.6 N MAX.	30.72
32P	3.2 N MAX.	35.04
40P	4.0 N MAX.	40.80
50P	5.0 N MAX.	48.00

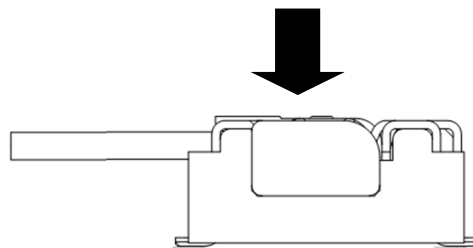

Fig. 6 実装状態での筐体押さえ荷重 (Press Load for Mated Connector)