

# CABLINE<sup>®</sup>-SS Connector

Part No. Plug: 20380-\*\*\*T-\*\*, Receptacle: 20374-\*\*\*E-\*\*-\*

## Product Specification

Qualification Test Report No. TR-04037

19	S22391	September 5, 2022	K. Hara	T. Tanigawa	H. Ikari
18	S22097	March 8, 2022	E. Tanaka	K. Hara	H. Ikari
17	S21627	November 24, 2021	R. Hatano	T. Tanigawa	H. Ikari
16	S19375	June 11, 2019	K. Hara	T. Masunaga	H. Ikari
Rev.	ECN	Date	Prepared by	Checked by	Approved by

## 1. Scope

This Product Specification defines the test conditions and the performances of the CABLINE-SS Connector, a wire-to-board connector of 0.4 mm contact pitch.

## 2. Product Name and Parts No.

### 2.1 Product Name

CABLINE-SS

### 2.2 Parts No.

- (1) CABLINE-SS PLUG FOR CABLE ASS'Y (Part No. 20380-\*\*\*T-\*\*)
  - CABLINE-SS PLUG HOUSING ASS'Y (Part No. 20373-\*\*\*T-0\*~\*)
  - CABLINE-SS METAL COVER (Part No. 2182-0\*\*~0\*\*)
- (2) CABLINE-SS RECEPTACLE ASS'Y (Part No. 20374-\*\*\*E-\*\*~\*)

## 3. Rating

### 3.1 Applicable Cable

AWG#42, #40, #36, #34

### 3.2 Operating Conditions

Amperage: 0.24A AC/DC [AWG#42] (apply to all pins)  
0.25A AC/DC [AWG#40] (apply to all pins)  
0.30A AC/DC [AWG#40] (maximum 32pins. / for POWER)  
0.35A AC/DC [AWG#36] (apply to all pins)  
0.40A AC/DC [AWG#36] (maximum 37pins. / for POWER)  
0.35A AC/DC [AWG#34] (apply to all pins)  
1.00A AC/DC [AWG#34] (maximum 2 pins. / for POWER)  
※AWG#36: Micro-Coax cable and Discrete cable  
※AWG#34: Discrete cable only  
※Contact us before applying amperage other than the above.

Voltage: 100V AC (per contact pin)

Operating temperature: 233~358K(-40°C~85°C)  
(Containing temperature rise by current)

Operating humidity: 85% max (Non-condensing)

### 3.3 Storage Conditions

Storage temperature: 248~333K(-25°C~60°C)

Storage humidity: 85% max. (Non-condensing)

Storage period:

Before opening ... 1 year after product is delivered.  
After opening, use it as soon as possible.

## 4. Test and Performance

### Test Condition

This initial test is equal to it's at shipping condition and unless otherwise specified, all tests and measurements shall be performed under the following conditions in accordance with MIL-STD-202.

Temperature... 288 K~308 K (15 °C~35 °C)

Pressure... 866 hPa~1066 hPa (650 mmHg~800 mmHg)

Relative humidity... 45~75 %R.H.

## 4.1. Electrical Performance

### 1. Contact resistance

Reference standard: MIL-STD-202, Method 307

Test conditions: Solder the receptacle connector to the test board and mate the plug connector together, then measure the contact resistance as shown in Fig.1 by the four terminal methods. Apply the low level condition of 20 mV MAX. DC for the open circuit voltage and 10 mA MAX. DC for the closed circuit current.

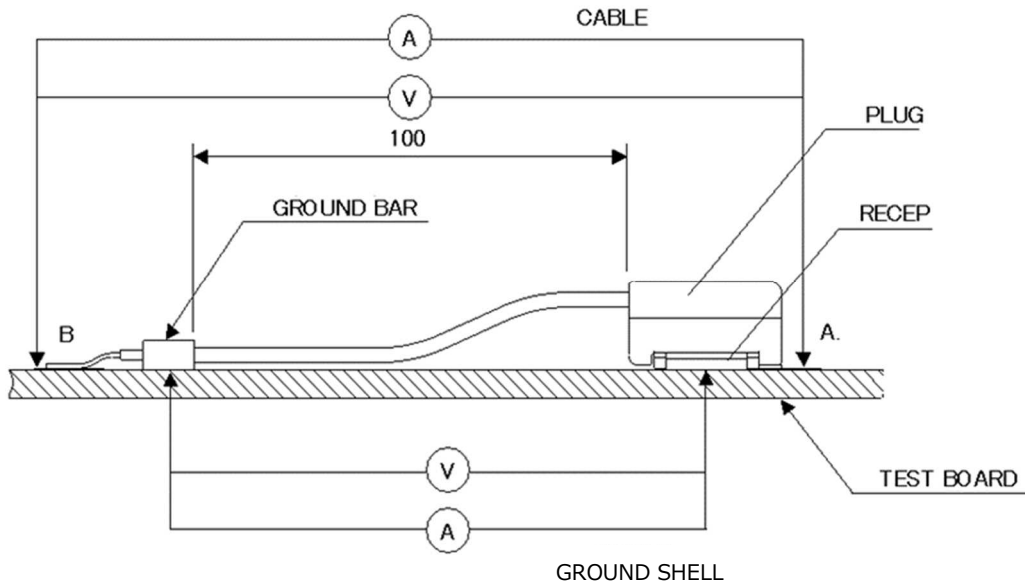

Fig.1

### Pass criteria:

#### Contact

Initial: 180 mΩ MAX. (AWG#34) 275 mΩ MAX. (AWG#36)

Initial: 600 mΩ MAX. (AWG#40) 700 mΩ MAX. (AWG#42)

After testing:  $\Delta$ R 40 mΩ MAX.

Initial contains the following conductor resistance of a cable 100 mm.

100 mΩ (AWG#34) 195 mΩ (AWG#36)

520 mΩ (AWG#40) 620 mΩ (AWG#42)

#### Ground Shell

Initial: 50 mΩ MAX. After testing:  $\Delta$ R 40 mΩ MAX.

## 4.1. Electrical Performance

2. Insulation resistance	
Reference standard:	MIL-STD-202, Method 302
Test conditions:	Mate the plug and receptacle connector together, then apply DC 250 V between the neighboring contacts.
Pass criteria:	Initial: 1,000 MΩ MIN. After testing: 500 MΩ MIN.

3. Dielectric withstanding voltage	
Reference standard:	MIL-STD-202, Method 301
Test conditions:	Mate the receptacle and plug connector together, then apply AC 250V(rms)between the neighboring contacts for a minute.
Pass criteria:	No creeping discharge, flashover, no insulator breakdown shall occur.

4. Temperature rising	
Reference standard:	-
Test conditions:	Mate the plug and receptacle connector together and then apply rating current per contact.
Pass criteria:	Over ambient $\Delta T30$ °C MAX.

## 4.2. Mechanical Performance

1. Mating force and Un-mating force				
Reference standard: -				
Test conditions: Solder the receptacle connector to the test board, then place the board and plug on push-on/pull-off machine, measure of initial and mating/unmating 30 cycles at a speed $25 \pm 3$ mm/min. along the mating axis.				
Pass criteria:	Mating force		Un-mating force	
		Initial and 30 cycles		Initial      30 cycles
	10 P	29.0 N MAX.	10 P	4.00 N MIN.      2.87 N MIN.
	14 P	29.8 N MAX.	14 P	4.40 N MIN.      3.23 N MIN.
	20 P	31.0 N MAX.	20 P	5.00 N MIN.      3.76 N MIN.
	30 P	33.0 N MAX.	30 P	6.00 N MIN.      4.65 N MIN.
	32 P	33.4 N MAX.	32 P	6.20 N MIN.      4.84 N MIN.
	35 P	34.0 N MAX.	35 P	6.50 N MIN.      5.07 N MIN.
	40 P	35.0 N MAX.	40 P	7.00 N MIN.      5.50 N MIN.
	50 P	38.0 N MAX.	50 P	8.00 N MIN.      6.41 N MIN.
	Au Type Mating force		Un-mating force	
		Initial      30 cycles		Initial      30 cycles
	35 P	40.8 N MAX.      34.0 N MAX.	35 P	5.26 N MIN.      3.07 N MIN.
	40 P	42.0 N MAX.      35.0 N MAX.	40 P	6.00 N MIN.      3.50 N MIN.

## 4.2. Mechanical Performance

2. Durability	
Reference standard:	-
Test conditions:	Solder the receptacle connector to the test board, then place the board and plug on the push-on/pull-off machine, and repeat mating and un-mating 30 cycles at a speed 25±3 mm/min. along the mating axis.
Pass criteria:	Contact resistance: Shall meet 4.1.1

3. Contact retention force	
Reference standard:	-
Test conditions:	Place the connector on the push-on/pull-off machine, then apply force on the contact head and push the contact along the direction opposite to the contact insertion at a speed of 25 ± 3 mm/min. Measure the force when the contact dislodges the connector.
Pass criteria:	Plug contact retention force: 0.6N MIN. Receptacle contact retention force: 0.2N MIN.

4. Cable retention force	
Reference standard:	-
Test conditions:	Place the plug connector on the push-on/pull-off machine and then apply force on the cable along the direction at a speed 25 ± 3 mm/min. Measure the force when the cable dislodges the plug connector.
Pass criteria:	10P: 4.90 N MIN. 14P: 6.86 N MIN. 20P: 9.80 N MIN. 30P: 14.70 N MIN. 32P: 15.68 N MIN. 35P: 17.15 N MIN. 40P: 19.60 N MIN. 50P: 24.50 N MIN.

5. Vibration	
Reference standard:	MIL-STD-202, Method 201
Test conditions:	Solder the receptacle connector to the test board, then mate plug connector, and place them on the vibrator. Then apply the following vibration. During the testing, run 100 mA DC to check electrical discontinuity. Frequency : 10 Hz→55 Hz→10 Hz/approx. 1 min. Directions : 3 mutually perpendicular directions. Total Amplitude: 1.52 mm Sweep duration: 2 hours for each direction, a total of 6 hours.
Pass criteria:	Contact resistance: Shall meet 4.1.1. Electrical discontinuity: No electrical discontinuity greater than 1µs shall occur. Appearance: No abnormality adversely affecting the performance shall occur.

6. Shock	
Reference standard:	MIL-STD-202, Method 213, Condition A.
Test conditions:	Solder the receptacle connector to the test board, then mate plug connector, and place them on the shock machine. Then apply the following shock. MAX.G: 50 G Directions: 6 mutually perpendicular direction Duration: 11 msec Cycle: 3 cycles about each direction Wave Form: Half Sinusoidal
Pass criteria:	Contact resistance: Shall meet 4.1.1. Electrical discontinuity: No electrical discontinuity greater than 1µs shall occur. Appearance: No abnormality adversely affecting the performance shall occur.

## 4.3. Environmental Performance

1. Thermal shock	
Reference standard:	MIL-STD-202, Method 107, Condition A.
Test conditions:	Solder the receptacle connector to the test board, then mate plug connector, and expose them to the following environment. Temperature: 218 K(-55 °C), 30 min.→358K(85 °C), 30 min. Transition time: 5 min. MAX. No. of cycles: 5 cycles
Pass criteria:	Contact resistance: Shall meet 4.1.1.

2. High temperature life	
Reference standard:	MIL-STD-202, Method 108, Condition B.
Test conditions:	Solder the receptacle connector to the test board, then mate plug connector, and expose them to the following environment. Temperature: 358 ± 2 K (85 ± 2 °C) Duration: 250 hours
Pass criteria:	Contact resistance: Shall meet 4.1.1. Contact retention force: Shall meet 4.2.3.

3. Humidity(Steady state)	
Reference standard:	MIL-STD-202, Method 103, Condition A.
Test conditions:	Solder the receptacle connector to the test board, then mate plug connector, and expose them to the following environment. Temperature: 313 ± 2 K (40 ± 2 °C) Humidity: 90~95 %RH Duration: 240 hours
Pass criteria:	Contact resistance: Shall meet 4.1.1. Insulation resistance: Shall meet 4.1.2. Dielectric withstanding voltage: Shall meet 4.1.3.

4. Humidity(Cycling)	
Reference standard:	MIL-STD-202, Method 106.
Test conditions:	Solder the receptacle connector to the test board, then mate plug connector, and expose them to the following environment. Temperature: 298 [263]~338 K (25 [-10]~65 °C) Humidity: 90~98 %RH Duration: 10 cycles (240hours)
Pass criteria:	Contact resistance: Shall meet 4.1.1. Insulation resistance: Shall meet 4.1.2. Dielectric withstanding voltage: Shall meet 4.1.3.

5. Salt water spray	
Reference standard:	MIL-STD-202, Method 101, Condition B.
Test conditions:	Solder the receptacle connector to the test board, then mate plug connector, and expose them to the following environment. Temperature: 308 ± 2 K (35 ± 2 °C) Salt water density: 5 ± 1 % [by weight] Duration: 48 hours
Pass criteria:	Contact resistance: Shall meet 4.1.1.

## 4.3. Environmental Performance

6. H <sub>2</sub> S gas	
Reference standard:	-
Test conditions:	Solder the receptacle connector to the test board, then mate plug connector, and expose them to the following environment. Temperature: $313 \pm 2$ K ( $40 \pm 2$ °C) Relative humidity: $80 \pm 5$ %RH Gas: H <sub>2</sub> S 3 ppm Duration: 96 hours
Pass criteria:	Contact resistance: Shall meet 4.1.1. Appearance: No abnormality adversely affecting the performance shall occur.

7. Cold Temperature Life	
Reference standard:	-
Test conditions:	Solder the receptacle connector to the test board, then mate plug connector, and expose them to the following environment in accordance. Temperature : $233 \pm 2$ K ( $-40 \pm 2$ °C) Duration : 250 hours
Pass criteria:	Contact resistance: Shall meet 4.1.1.

## 4.4. Others

1. Solder ability	
Reference standard:	MIL-STD-202, Method 208.
Test conditions:	Dip the solder tine of the contact in the solder bath at $518 \pm 5 \text{ K}$ ( $245 \pm 5 \text{ }^\circ\text{C}$ ) for $5 \pm 0.5$ seconds after immersing the tine in the flux of RMA or R type for 5 to 10 seconds.
Pass criteria:	More than 95 % of the dipped surface shall be evenly wet.

## 2. Soldering heat resistance

Reference standard: -

Test conditions: (Reflow) Reflow temperature as shown in Fig.2.  
The number of times of Reflow is within 1. However, when it executes the 2 times of reflow or the N2 reflow, we recommend the Ni barrier type.

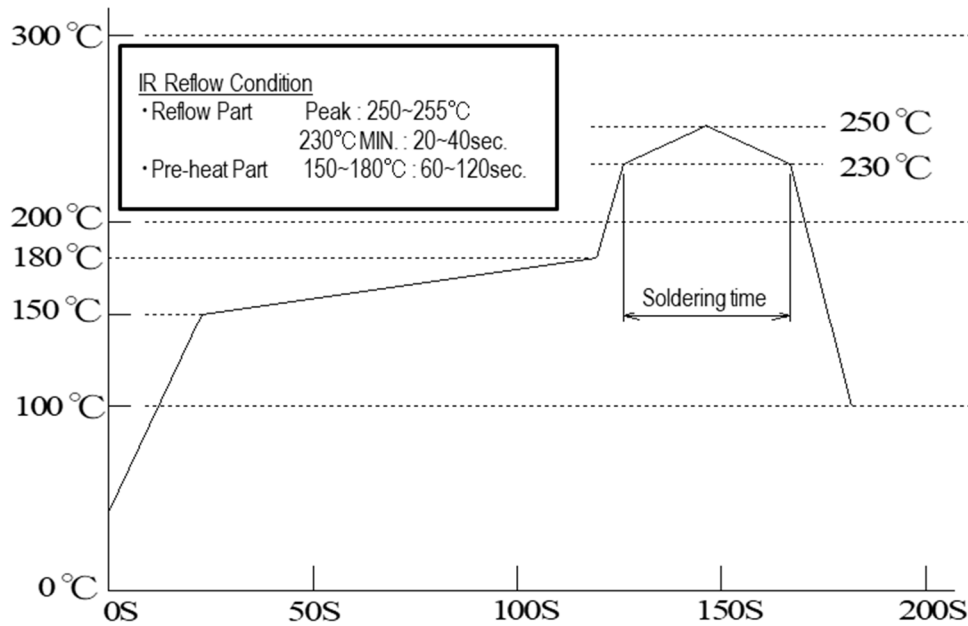

Fig.2

Pass criteria: No abnormality adversely affecting the performance shall not occur.

Test conditions: (Soldering iron) Operating temperature : 613~633K ( $350^\circ\text{C} \pm 10$ )  
Application time of soldering iron :  $5 \pm 1$ sec.  
The number of times of application : 3times

Pass criteria: No abnormality adversely affecting the performance shall not occur.



## 4.5 Test Sequence and Specimen Quantity

**Table 1 Test Sequence and Sample Quantity**

Test Item	Group												
	A	B	C	D	E	F	G	H	J	K	L	M	N
C/T Resistance	2,6		1,3,5	1,3	1,3	1,5	1,5,7	1,3	1,3	1,3		.	
Insulation Resistance						2,6	2,8						
D. W. Voltage						3,7	3,9						
Temperature rising													1
Mating Force	1,5												
Un-mating Force	3,7												
Durability	4						4 (10cycles)						
Contact Retention Force		1,3											
Cable Retention Force	8												
Vibration			2										
Shock			4										
Thermal Shock				2									
High Temp. Life		2			2								
Humidity (Steady State)						4							
Humidity (Cycling)							6						
Salt Water Spray								2					
H2S Gas									2				
Cold Temperature Life										2			
Solder ability											1		
Soldering Heat Resistance												1	
Sample QTY.	5 pcs.	20 pcs.	5 pcs.	5 pcs.	5 pcs.	5 pcs.	5 pcs.	5 pcs.	5 pcs.	5 pcs.	10 pcs.	10 pcs.	5 pcs.

※Numbers indicate sequence in which tests are performed.

## 5. Recommended Metal Mask

Refer to drawing for the recommended metal mask thickness and opening dimension.

## 6. Precautions for Handling Cable Connectors

Refer to instruction manual:HIM-04001 for the handling of CABLINE-SS.