

ISH[®] CONNECTOR HYBRID FEMALE SUB ASS'Y

Packing Standard

| | | | | | |
|------|--------|-------------------|-------------|------------|-------------|
| 8 | RS0887 | February 21, 2022 | K.Tsusu | T.Takeda | J.Tateishi |
| 7 | RS0884 | December 23, 2021 | K.Tsusu | T.Takeda | J.Tateishi |
| 6 | RS0860 | September 8, 2021 | K.Tsusu | T.Takeda | J.Tateishi |
| 5 | RS0742 | November 9, 2020 | S.Tono | J.Tateishi | E.Kawabe |
| Rev. | ECN | Date | Prepared by | Checked by | Approved by |

1. Product name(s) and part number(s)

| Poles | Part number | Key coding | Lock type | Insertion auxiliary part |
|-------|----------------|------------|-----------|--------------------------|
| 20P | V0072-020B-111 | A | Inertia | Option (Rear cover) |
| | V0072-020B-112 | B | Inertia | Option (Rear cover) |
| 28P | V0072-028B-112 | - | Normal | Built-in |

2. Packing material and quantity

| Poles | Part number | Packing bag | Packing carton | Pieces per packing bag [pcs] | Quantity per packing carton [pcs] |
|-------|----------------|----------------------------|------------------------------|------------------------------|-----------------------------------|
| | | Outer dimension (W×D) [mm] | Outer dimension (W×D×H) [mm] | | |
| | | 20P | V0072-020B-11* | | |
| 28P | V0072-028B-112 | 260 x 380 | 406×406×214 | 150 | 150 × 8 bags = 1,200 |

3. Label

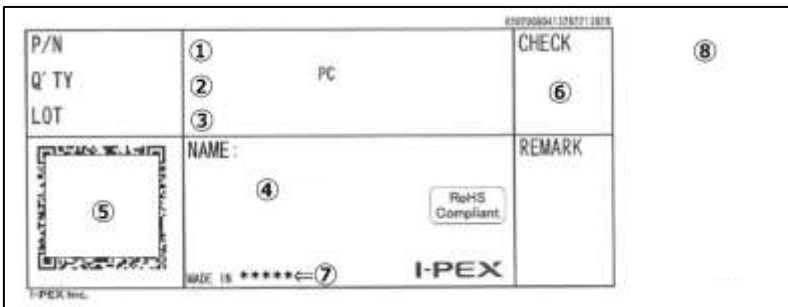

- ① Part number
- ② Quantity
- ③ Ten digits product lot number

| Y | Y | M | M | D | D | # | # | # | # |
|------|---|-------|---|-----|---|--------|---|---|---|
| Year | | Month | | Day | | Note 1 | | | |

Note 1: Code for plant usage.

- ④ Product name (abbr.)
- ⑤ QR code
- ⑥ Check stamp
- ⑦ Country of origin
- ⑧ Recycle mark and compliance mark

4. 梱包形態

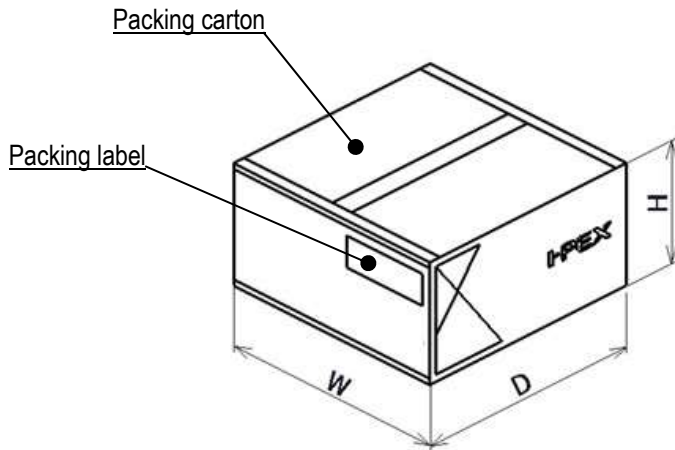

Fig 1. Packing carton

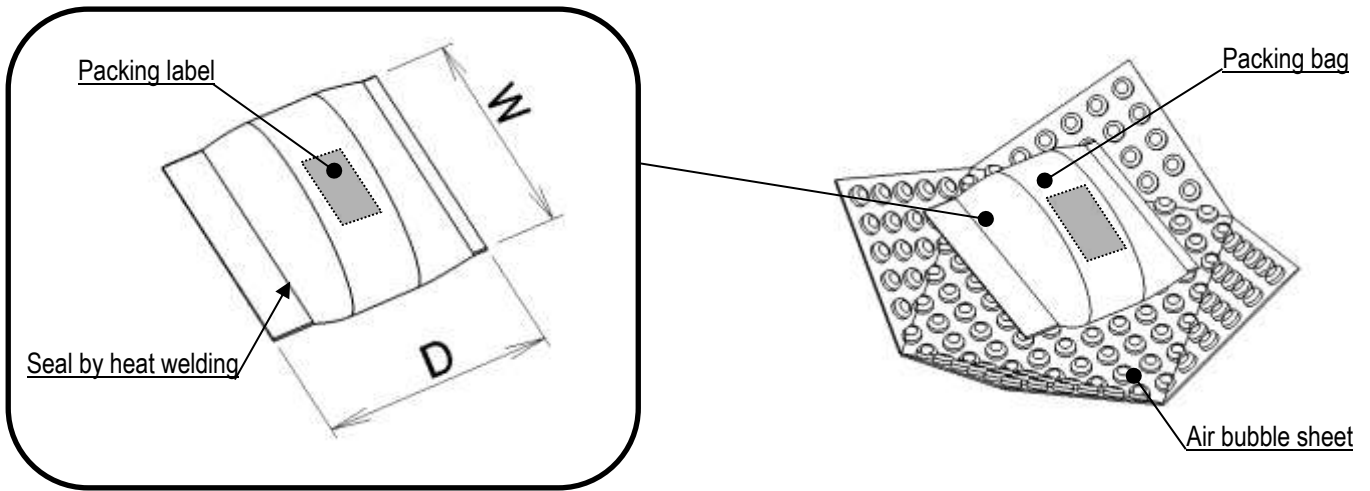

Fig 2. Packing bag

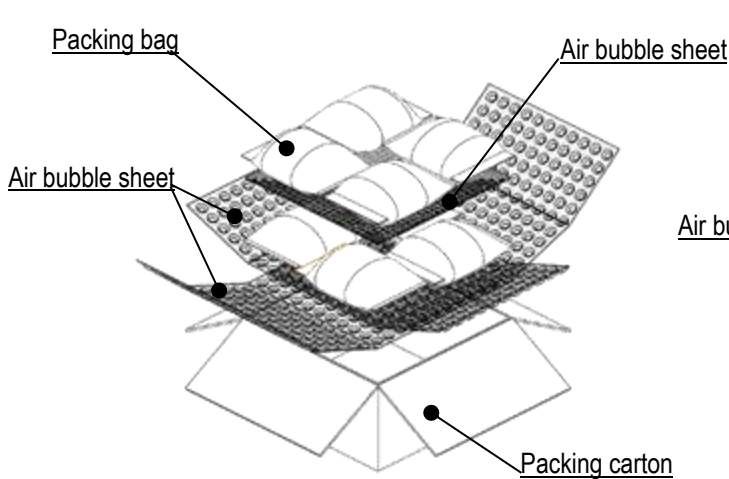

Fig 3. Packing style (20P)

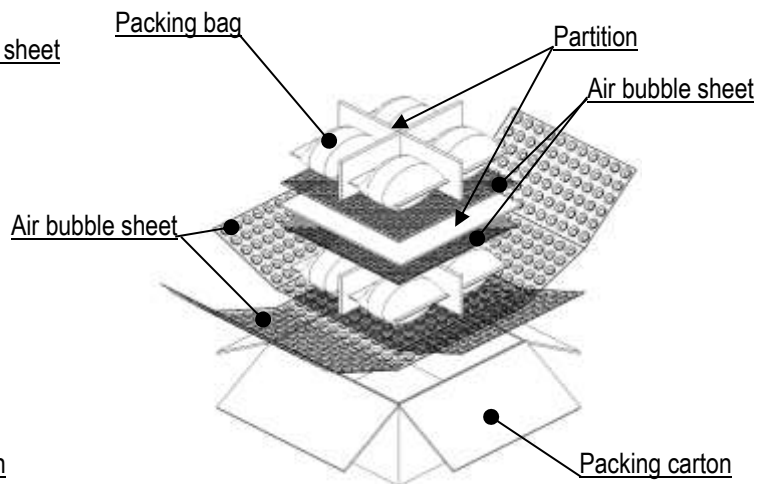

Fig 4. Packing style (28P)