

梱包規格 (Packing Standard)



1. 製品名称 (NAME) : CABLINE-CBL CONN. PLUG SHELL A

製品番号 (ITEM) : 2618-0***#

2. 梱包材料 (PACKING MATERIAL)

芯数 (POS.)	リール径 (DIAMETER)	リール幅 (REEL WIDTH)	リール P/N (REEL P/N)	外装カートン (PACKING CARTON) P/N 950000-001
30P	φ 380	44.0	950229-001	406×406×214 OUTER
40P		49.0	950229-002	

芯数 (POS.)	リール本数 (REEL QTY.)	入数[リール 1 本当たり] (QTY.[1 REEL])	外装カートン入数 (QTY. IN PACKING CARTON)
30P	3 本(REELS)	6000	6000×3=18000
40P			

CUSTOMER COPY

For ALL

					Prepared by : N.Hamauchi Apr./10/'08	Product name : CABLINE-CBL CONN. PLUG SHELL A
2	S12032	Y.W	Jan./25/'12	E.K	Reviewed by :	
1	S08113	N.H	May/20/'08	E.K	Approved by : E.Kawabe Apr./17/'08	No. 3 0 0 - 6 5 5 (C)
0	S08063	N.H	Apr./10/'08			
Rev.	ECN	BY	DATE	APP.		

I-PEX Confidential III C



Form Rev. 3

梱包規格 (Packing Standard)



4. 現品票 (LABEL)

- 4-1 現品票は、各 REEL、P CARTON へ貼付する。
- 4-2 現品票(ラベル)の記入事項は、別規定(PCS-1004)に従う。
- 4-3 現品票は、PART NO. 950005-001(UL マーク無し)を使用する。
- 4-1 Put a label on each reels and P CARTON.
- 4-2 Items of label are shown as below.
- 4-3 Use a label of Part number 950005-001 without UL mark.

20090909011300-00001		
P/N	①	CHECK
QTY	②	⑥
LOT	③	REMARK
	NAME: ④ RoHS Compliant  MADE IN JAPAN	 原包装品 WPP 層間紙 WPP
DAI - ICHI SEIKO CO., LTD		

- ①・・・ Part number : Ex. 2618-0**#
- ④・・・ Item : Ex. CABLINE-CBL CONN. PLUG SHELL A
- ②・・・ QTY.
- ⑤・・・ QR code
- ③・・・ Products lot No.
- ⑥・・・ Check stamp

It is constituted from six figures.(See below.)

 NN NN NN
 A B C

- A: Last two figures of the Christian era (two figures)
- B: Month (two figures)
- C: Day (two figures)

Example: 080117

It means that the Product was manufactured on Jan./17/2008.

CUSTOMER COPY

Product name :
 CABLINE-CBL CONN. PLUG
 SHELL A

No.
 3 0 0 - 6 5 5 (C)

梱包規格 (Packing Standard)



5. 梱包形態 (PACKING STYLE)

5-1 リールへの梱包 (PACKING OF REEL)

- (1) シェルのリールへの巻き方向は、図1に従う事。
- (2) 巻き数は、6000個/リールの事。

- (1) Coiling of shell to reel follow as shown Fig.1.
- (2) Coiling QTY. is 6000 in reel.

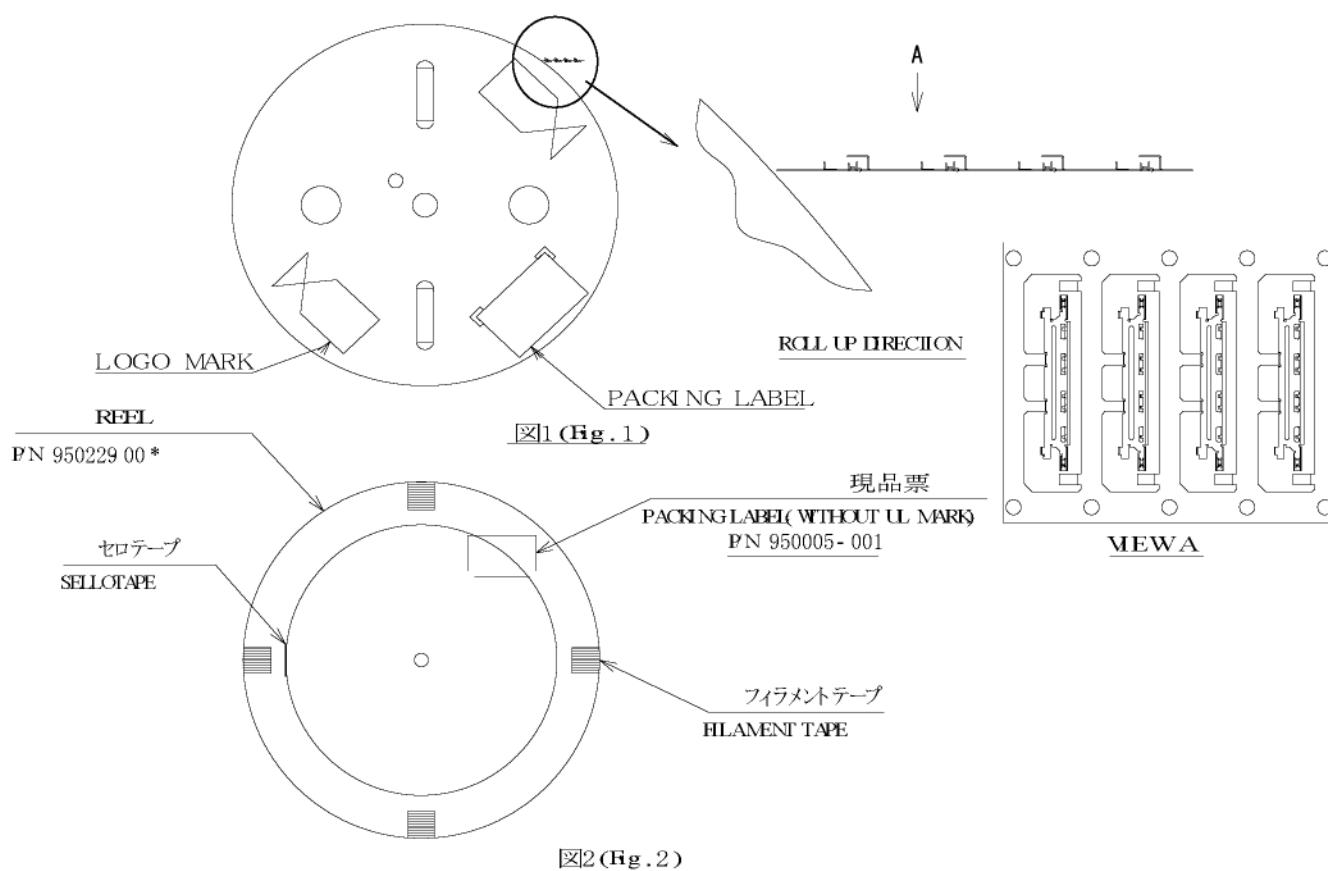

CUSTOMER COPY

Product name :
CABLNE-CBL CONN. PLUG
SHELL A

No.
3 0 0 - 6 5 5 (C)

梱包規格 (Packing Standard)



5-2 外装カートンへの梱包 (Packing of P CARTON)

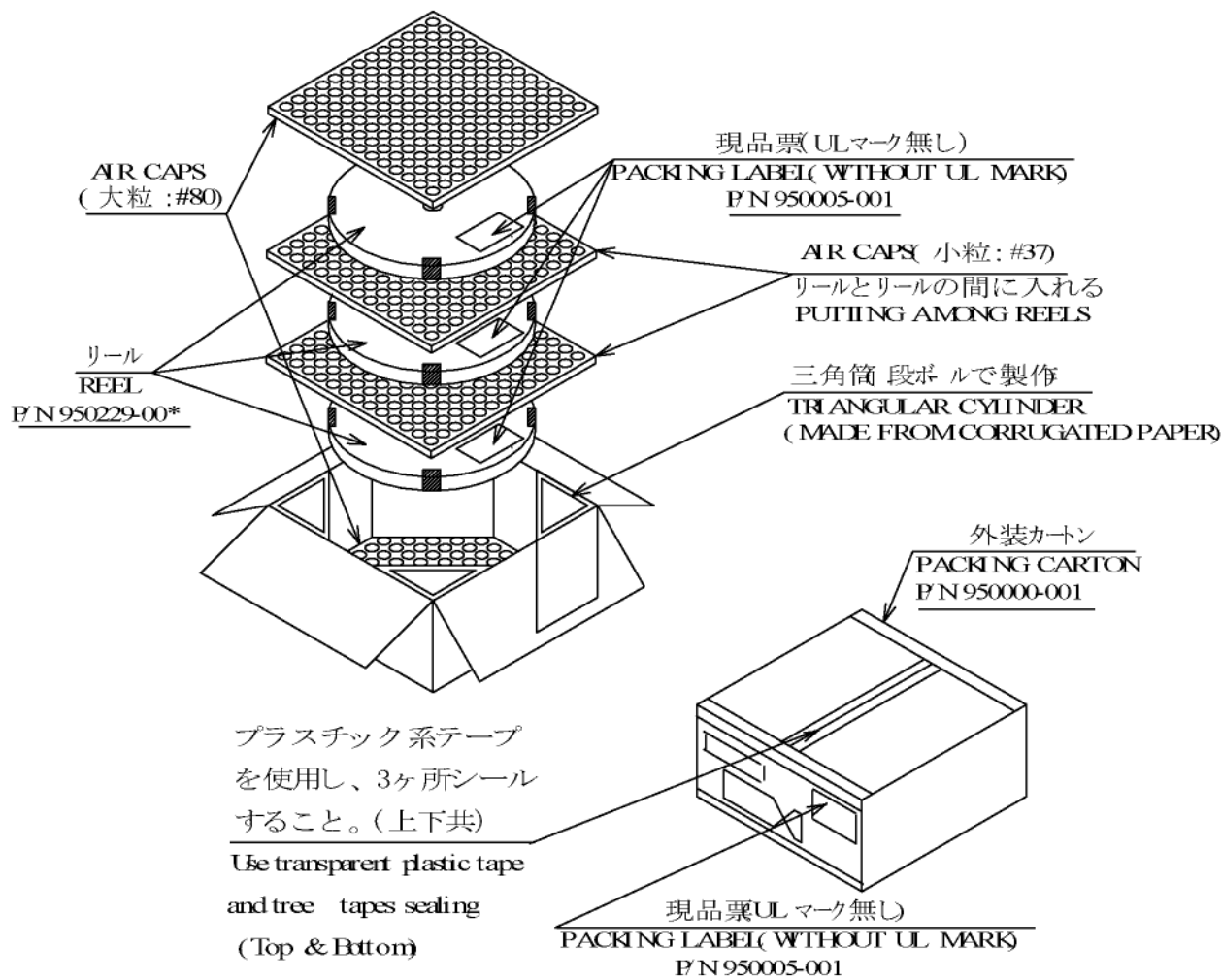

図 3(Fig.3)

CUSTOMER COPY	
Product name : CABLIN-CBL CONN. PLUG SHELL A	
No. 3 0 0 - 6 5 5 (C)	