

# CABLINE® -CA IIP PLUS 60P HARNESS

Part No. 82065-\*\*\*B-0\*

## Packing Standard

Rev.	ECN	Date	Prepared by	Checked by	Approved by
0	S24429	October 22, 2024	R.Takei	-	H.Ikari

## 1. Product Name(s) and Part Number(s)

Product Name	Part Number
CABLINE-CA IIP PLUS 60P HARNESS	82065 - *** B - **

## 2. Packing Material and Part Number

Part Number	Small Bag	Shipping Carton	Packing Carton
	Outer Dimension	Outer Dimension	Outer Dimension
	W×D×H	W×D×H	W×D×H
82065-600B-01	60 × 350 × 0.05		
82065-600B-02	120 × 350 × 0.05		
82065-600B-03	60 × 350 × 0.05		
82065-600B-04	120 × 350 × 0.05		
82065-400B-01	60 × 350 × 0.05		
82065-400B-02	120 × 350 × 0.05	385 × 175 × 90	406 × 406 × 214
82065-400B-03	60 × 350 × 0.05		
82065-400B-04	120 × 350 × 0.05		
82065-100B-01	60 × 350 × 0.05		
82065-100B-02	120 × 350 × 0.05		
82065-100B-03	60 × 350 × 0.05		
82065-100B-04	120 × 350 × 0.05		

### 3. Packing Quantity

Part Number	Pieces per Small Bag	Pieces per Shipping Carton	Quantity Per Packing Carton ( 4 shipping carton )
82065-600B-01	1	100 max.	100 × 4 = 400 max.
82065-600B-02		80 max.	80 × 4 = 320 max.
82065-600B-03		100 max.	100 × 4 = 400 max.
82065-600B-04		80 max.	80 × 4 = 320 max.
82065-400B-01		125 max.	125 × 4 = 500 max.
82065-400B-02		100 max.	100 × 4 = 400 max.
82065-400B-03		125 max.	125 × 4 = 500 max.
82065-400B-04		100 max.	100 × 4 = 400 max.
82065-100B-01		125 max.	125 × 4 = 500 max.
82065-100B-02		100 max.	100 × 4 = 400 max.
82065-100B-03		125 max.	125 × 4 = 500 max.
82065-100B-04		100 max.	100 × 4 = 400 max.

### 4. Label

4.1 Put a label on the designated place of S CARTON and P CARTON.

P/N	①	CHECK
QTY	②	⑥
LOT	③	
 ⑤	NAME: ④	REMARK
	MADE IN ***** ←⑦	⑧

⑨

- ① Part Number
- ② Quantity
- ③ Ten Digits Product Lot Number

Y	Y	M	M	D	D	#	#	#	#
Year		Month		Day		Four Digit Code for I-PEX usage			

- ④ Product Name
- ⑤ QR Code
- ⑥ Check Stamp
- ⑦ Country of Origin
- ⑧ Logo Mark
- ⑨ Manufacture Name

5. Packing style

Part Number	Small Bag	One shipping carton & One packing carton
82065-600B-01	Fig.1	
82065-600B-02	Fig.2	
82065-600B-03	Fig.1	
82065-600B-04	Fig.2	
82065-400B-01	Fig.1	
82065-400B-02	Fig.2	Fig. 3, 4, 5, 6, 7, 8
82065-400B-03	Fig.1	
82065-400B-04	Fig.2	
82065-100B-01	Fig.1	
82065-100B-02	Fig.2	
82065-100B-03	Fig.1	
82065-100B-04	Fig.2	

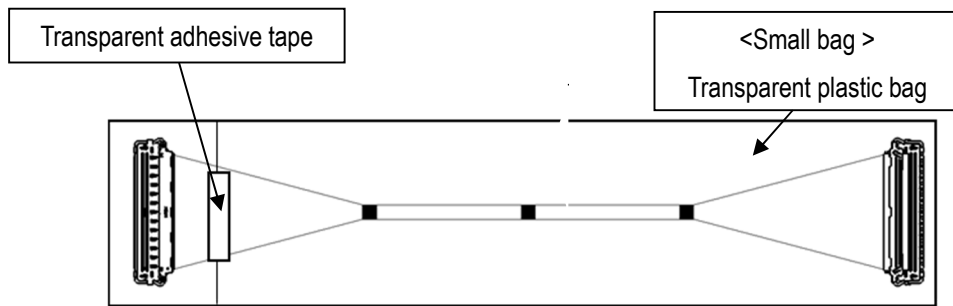

Fig.1 Small bag

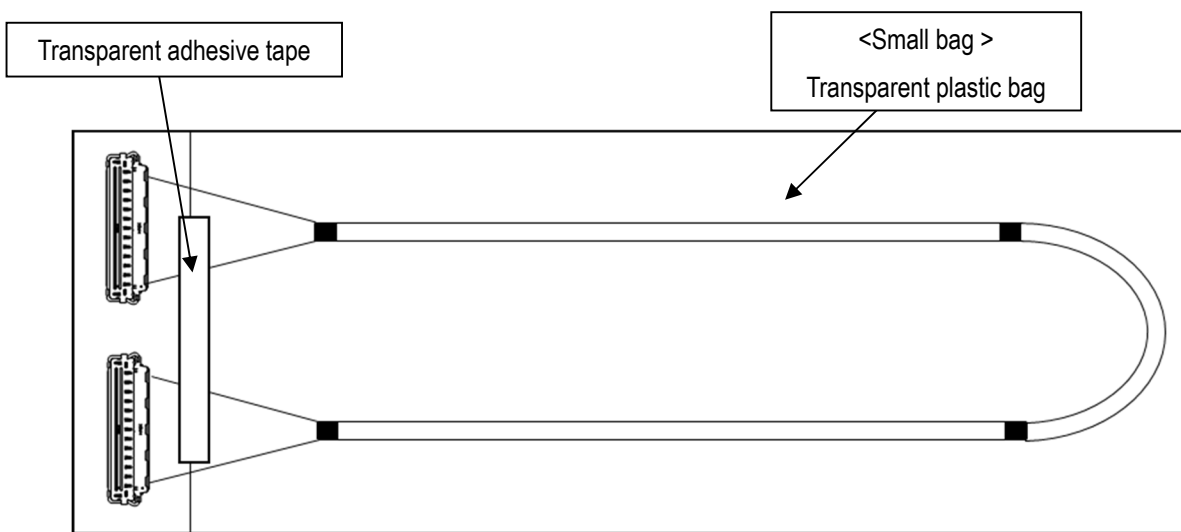

Fig.2 Small bag

## 6. Packing method

### 6-1. Packing method to put products into the shipping carton

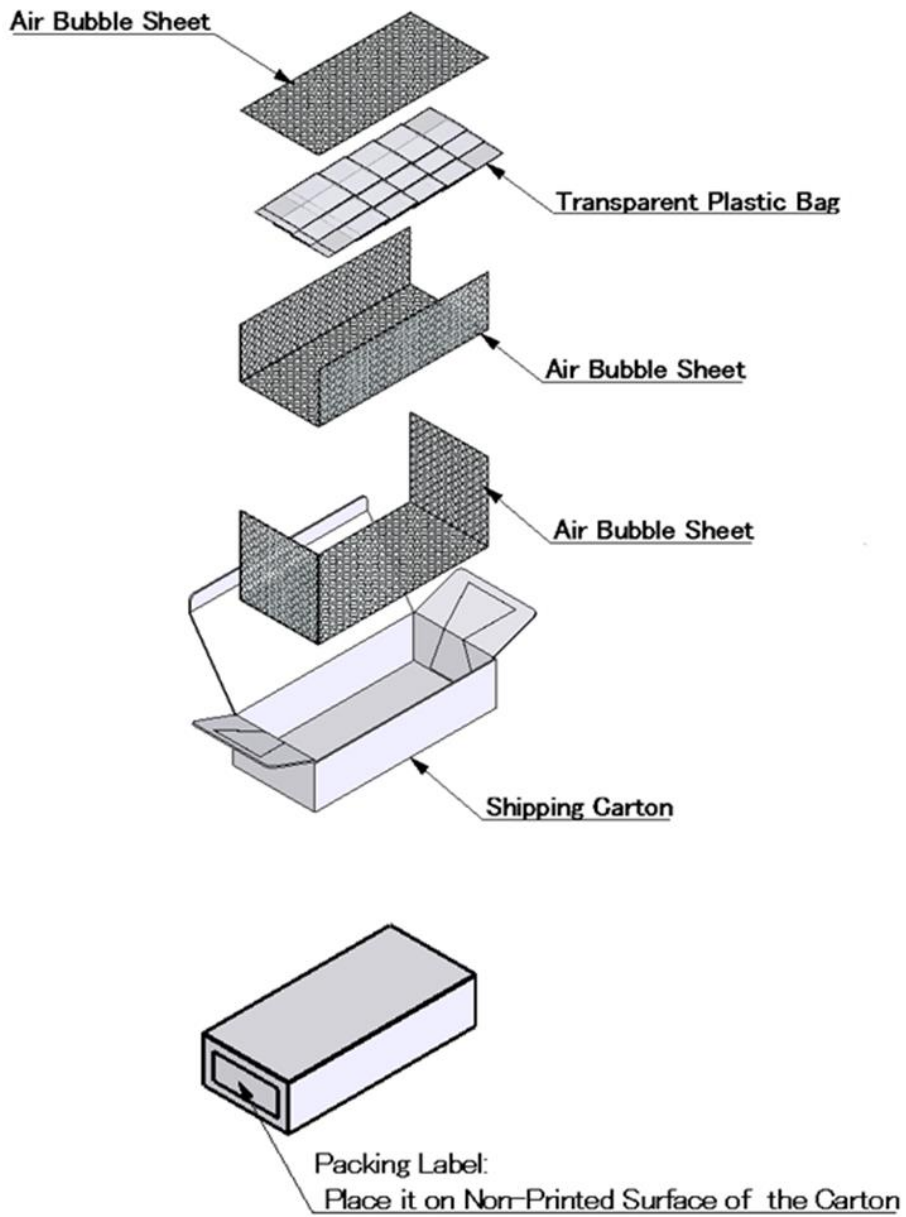

Fig.3

## 6-2. Packing method to pack Shipping carton into Packing carton

① At one shipping carton  
(Quantity : A [ pcs. ])

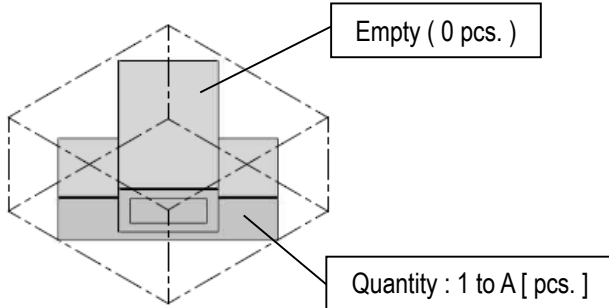

Fig.4

② At two shipping carton  
(Quantity : B [ pcs. ])

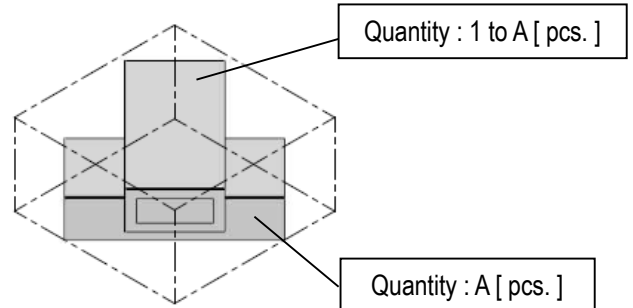

Fig.5

③ At three shipping carton  
(Quantity : C [ pcs. ])

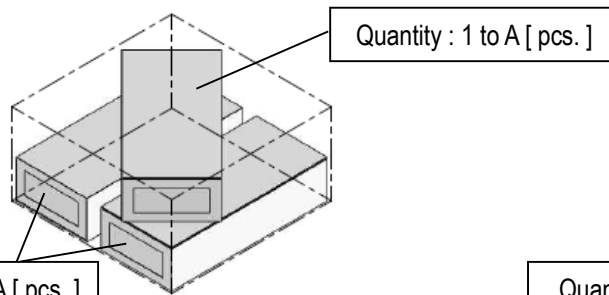

Fig.6

④ At four shipping carton  
(Quantity : D [ pcs. ])

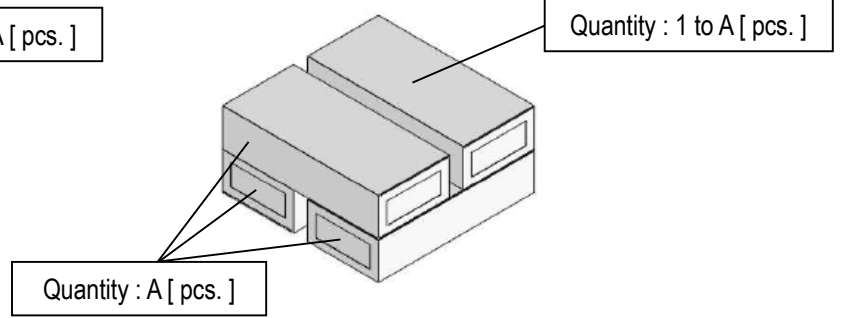

Fig.7

Part Number	①Quantity of A [ pcs. ]	②Quantity of B [ pcs. ]	③Quantity of C [ pcs. ]	④Quantity of D [ pcs. ]
82065-600B-01	100 max.	101 to 200 max.	201 to 300 max.	301 to 400 max.
82065-600B-02	80 max.	81 to 160 max.	161 to 240 max.	241 to 320 max.
82065-600B-03	100 max.	101 to 200 max.	201 to 300 max.	301 to 400 max.
82065-600B-04	80 max.	81 to 160 max.	161 to 240 max.	241 to 320 max.
82065-400B-01	125 max.	126 to 250 max.	251 to 375 max.	376 to 500 max.
82065-400B-02	100 max.	101 to 200 max.	201 to 300 max.	301 to 400 max.
82065-400B-03	125 max.	126 to 250 max.	251 to 375 max.	376 to 500 max.
82065-400B-04	100 max.	101 to 200 max.	201 to 300 max.	301 to 400 max.
82065-100B-01	125 max.	126 to 250 max.	251 to 375 max.	376 to 500 max.
82065-100B-02	100 max.	101 to 200 max.	201 to 300 max.	301 to 400 max.
82065-100B-03	125 max.	126 to 250 max.	251 to 375 max.	376 to 500 max.
82065-100B-04	100 max.	101 to 200 max.	201 to 300 max.	301 to 400 max.

## 6-3. Packing method of packing carton

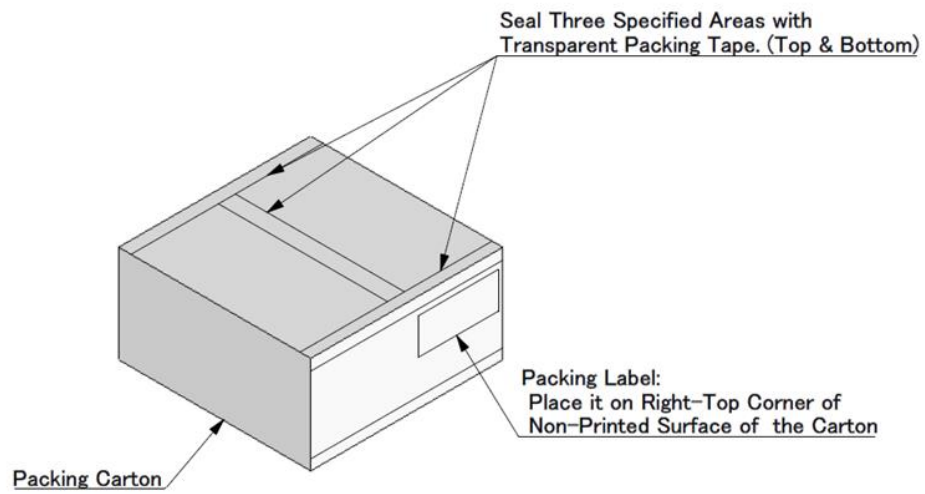

Fig.8