

MHF® 7S SMA ADAPTER

Part No. Plug:91255-0001 Receptacle:91256-0001

Instruction Manual

Rev.	ECN	Date	Prepared by	Checked by	Approved by
0	S22511	November 28, 2022	Y. Imaji	K. Yufu	Y. Hashimoto

1. Purpose

This document contains instruction manual on inspection adapters for MHF 7S Connector, MHF 7S PLUG / RECEPTACLE SMA ADAPTER for safe operation and cautions on test procedures. Refer to instruction manual on MHF 7S before usage.

○ Inspection Adapter

Product name: MHF 7S PLUG SMA ADAPTER

Part number: 91255-0001 (for MHF 7S PLUG)

Product name: MHF 7S RECEPTACLE SMA ADAPTER

Part number: 91256-0001 (for MHF 7S RECEPTACLE)

○ Connector

Product name: MHF 7S PLUG

Part number: 20980-001R-13

Product name: MHF 7S RECEPTACLE

Part number: 20981-001E-02

【SMA adapter parts names】

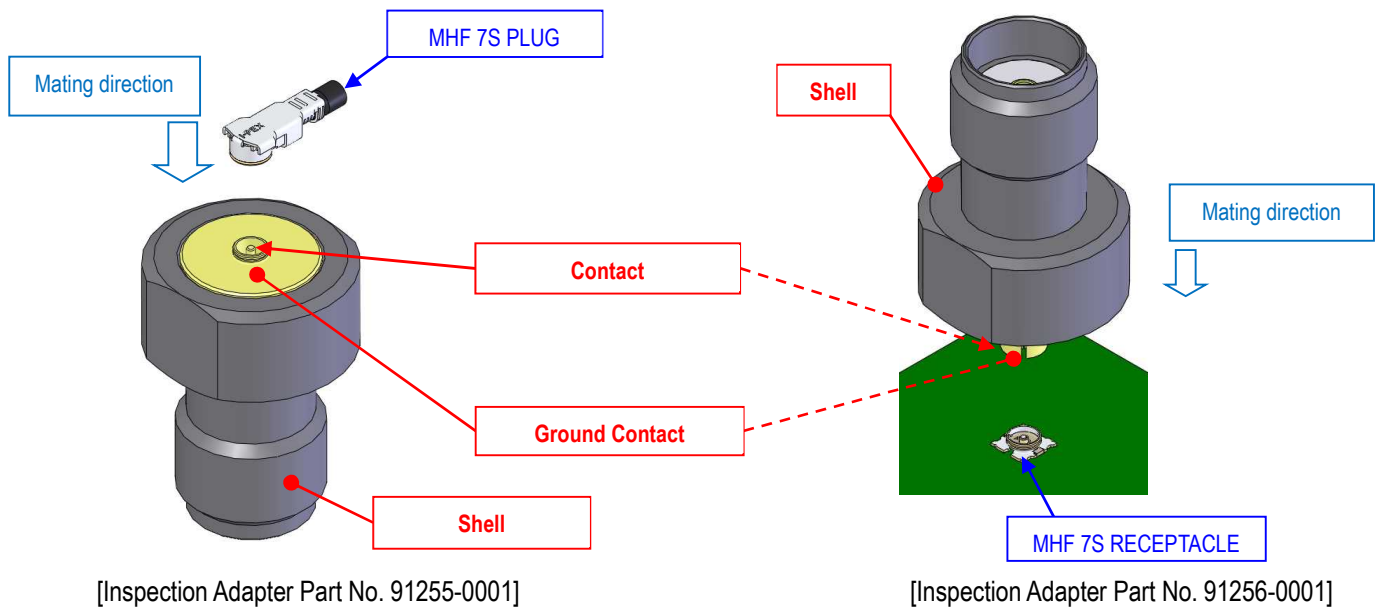

Fig. 1

2. Inspection Adapter Dimensions

Peripheral components of MHF 7S Connector shall not interference to the inspection adapter when mating with MHF 7S Connector.

[Dimension of inspection adapter unit: mm]

MHF 7 PLUG SMA ADAPTER
Part No. 91255-0001

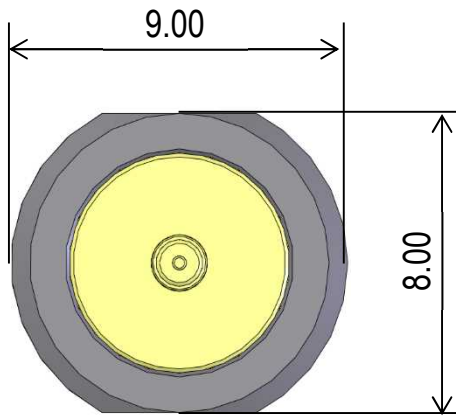

MHF 7 RECEPTACLE SMA ADAPTER
Part No. 91256-0001

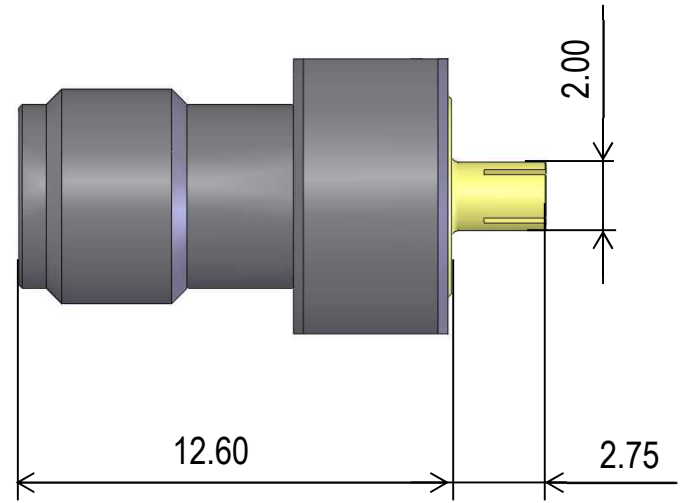
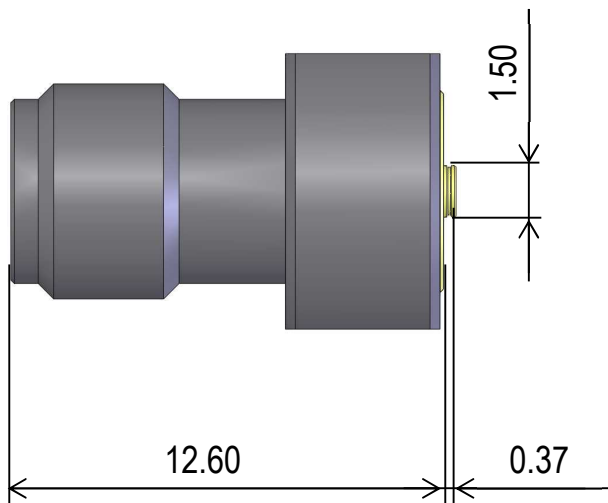
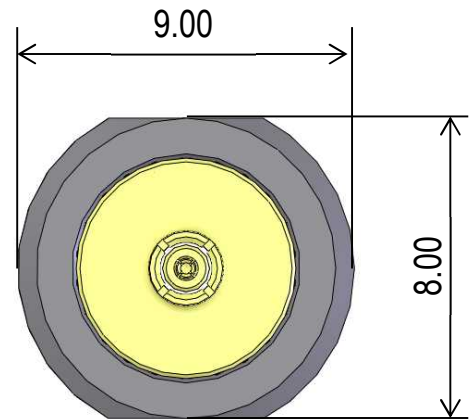

Fig.2

CAUTION

- Interference will damage the components and causes inspection failure.

【How To Fasten Inspection Adapter】

[91255-0001 / 91256-0001]

As shown in Fig. 3, hold SMA-J with wrench and tighten SMA-P by screwing with 0.59 - 0.98 N·m torque wrench.

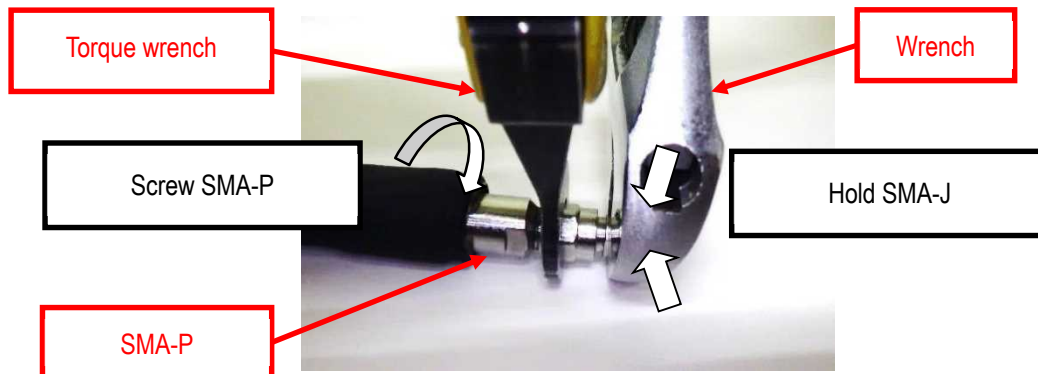

Fig. 3

CAUTION

• Screw only SMA-P side. Proper torque 0.59 - 0.98 N·m is recommended to fasten SMA-P. Excess torque may cause the breakage of a SMA connector.