

MHF[®]4L PLUG 13Type

Mating and Unmating Tweezer

Part No. 90615-0013

Instruction Manual

1	S23435	December 6, 2023	K.Tanaka	K.Yufu	Y.Hashimoto
0	S14285	July 17, 2014	H.Minegishi	T.Matsumoto	T.Takano
Rev.	ECN	Date	Prepared by	Checked by	Approved by

<Contents>

- 1. Abstract Page 3
- 2. Specification Page 3
- 3. Cautions in use Page 4
- 4. Operating procedure
 - 4-1.Mating plug Page 5~6
 - 4-2. Unmating plug Page 7~8

1. Abstract

This document is the instruction manual of MHF4L plug 13Type mating and unmating tweezer for I-PEX MHF4L plug 13type.

2. Specification

Name	MHF4L PLUG 13Type Mating and Unmating Tweezer
P/N	90615-0013
Outer dimension, weight	(W)4.2mm×(D)8.0(2.0)mm×(H)100mm About 17g
Applicable product	MHF4L PLUG(1.13) (P/N : 20565-001R-13)

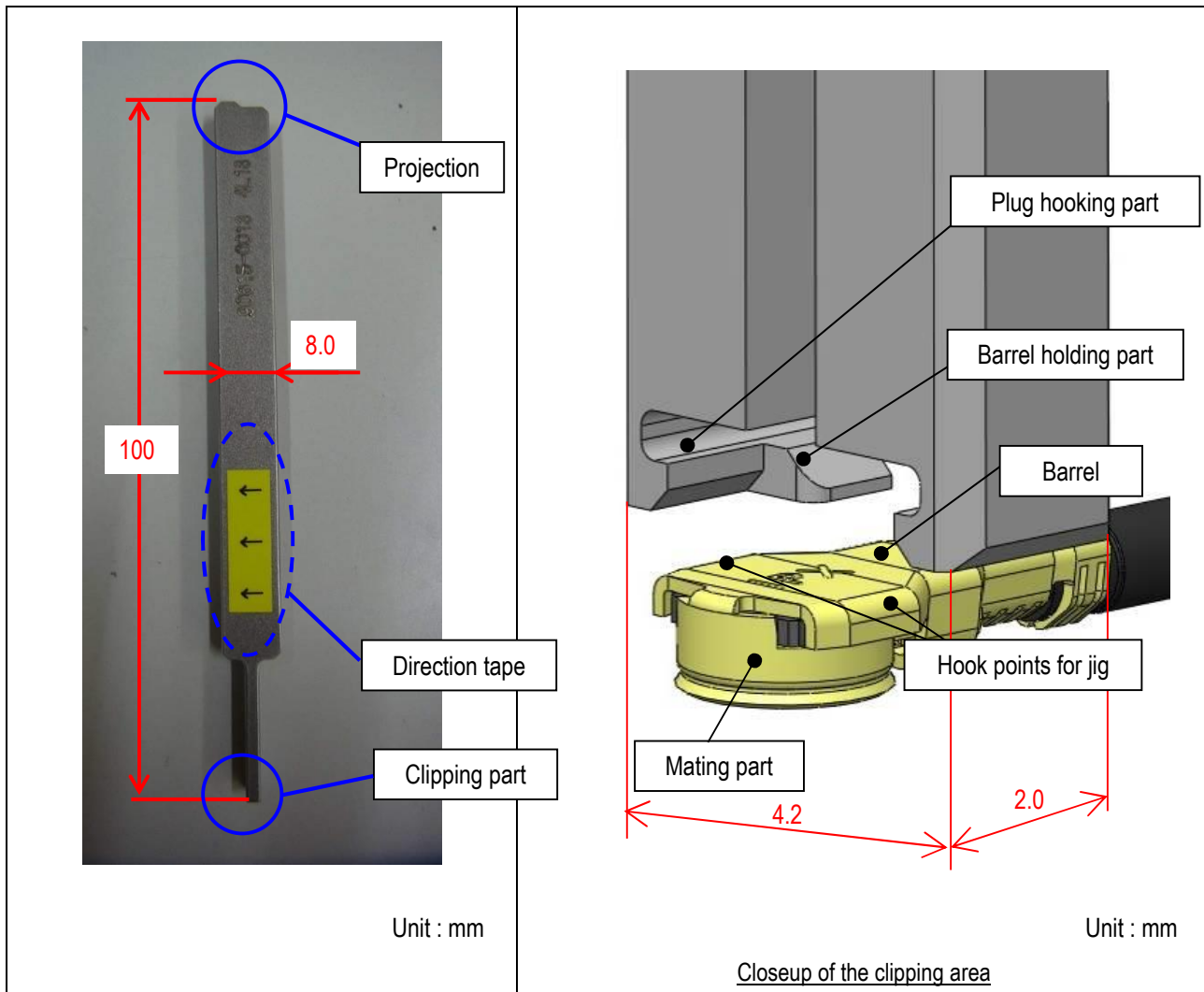

3. Cautions in use

< The direction to clip the plug >

Set this jig so that the projection and the arrow of the direction tape indicate the plug side, then clip the plug.

The clipping part of the jig consists of the barrel holding part and the plug hooking part. Please not clip the plug mating part with the barrel holding part.

Pass

Set the projection to Plug side

Set the arrow of the direction tape to Plug side.

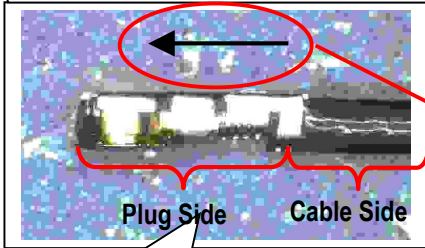

Set the jig so that the arrow of the direction tape indicates the PLUG side, then clip the PLUG.



FAIL

The projection on the cable side

The arrow of the direction tape on the cable side.



Please NOT set the jig so that the arrow of the direction tape indicates the cable side.



4. Operating procedure

4.1 Mating plug

STEP1 : Paying attention to the jig direction (see the clause 3 “Cautions in use”), set the jig so that the cable comes between the barrel holding part.

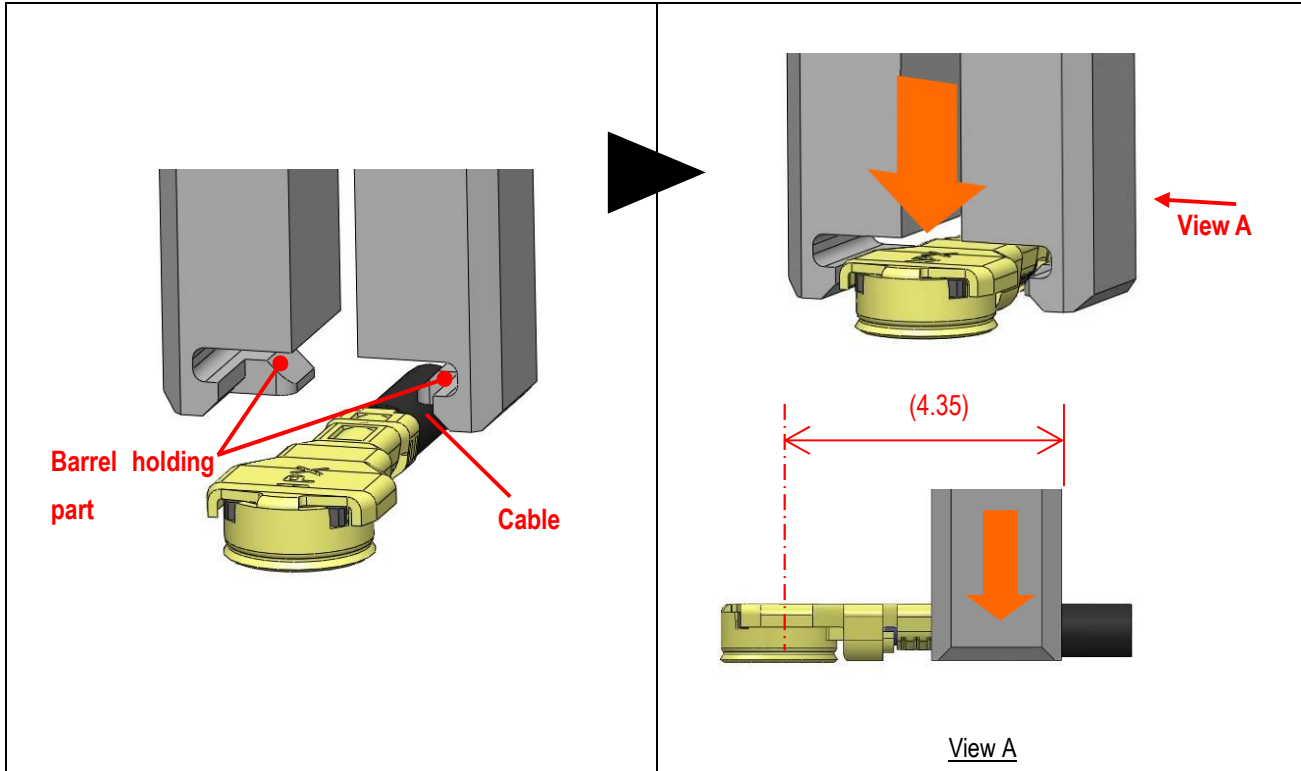

STEP2 : Closing the jig lightly, slide it to the end.

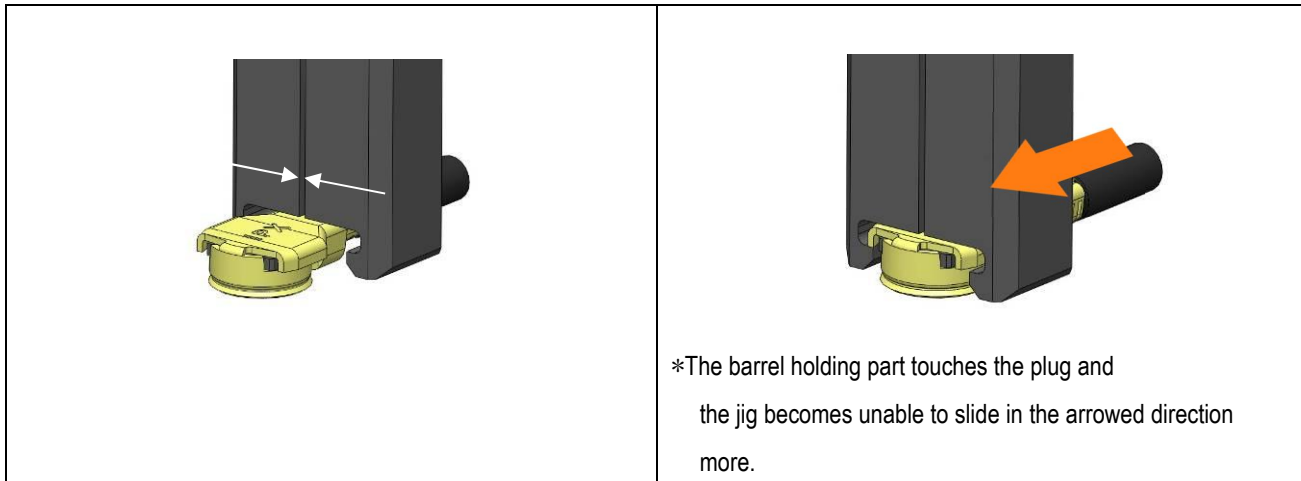

Caution①

To avoid miss clipping of the plug, please slide the jig until the barrel holding part touches the plug

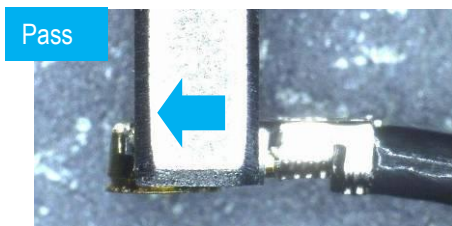

Slide the jig until the barrel holding part touches the plug.

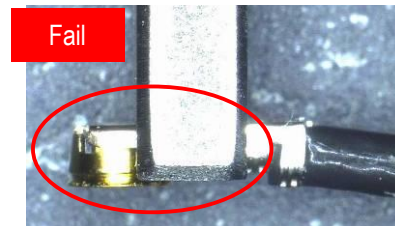

Insufficient sliding of jig

STEP3 : Clip the plug and insert it matching the plug mating part with the receptacle mating part.

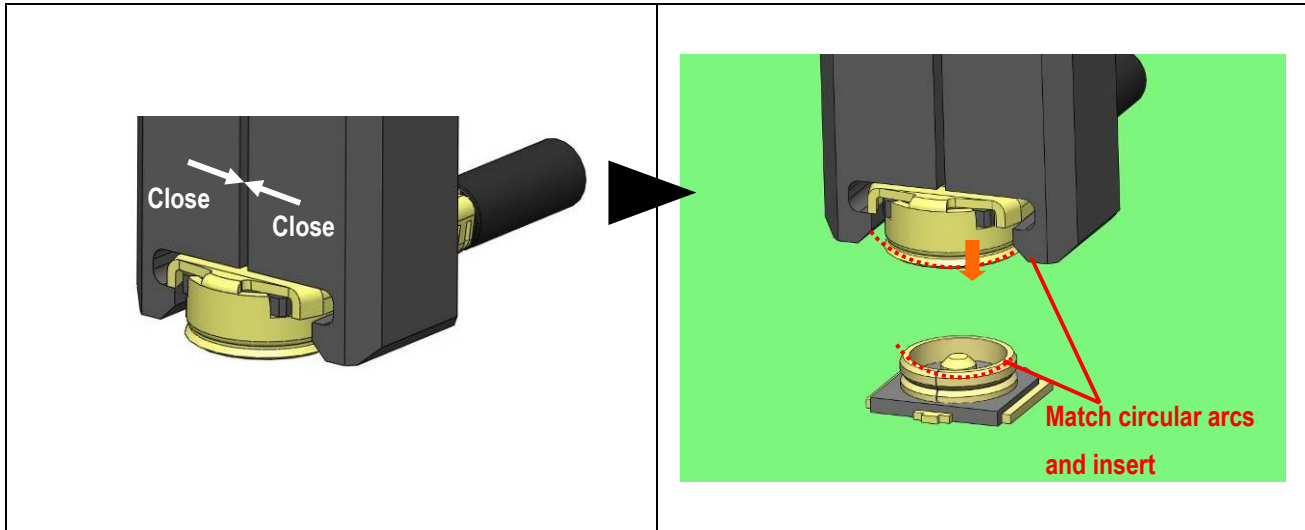

Caution②

In inserting plug to receptacle, please match the mating parts of plug and receptacle certainly.

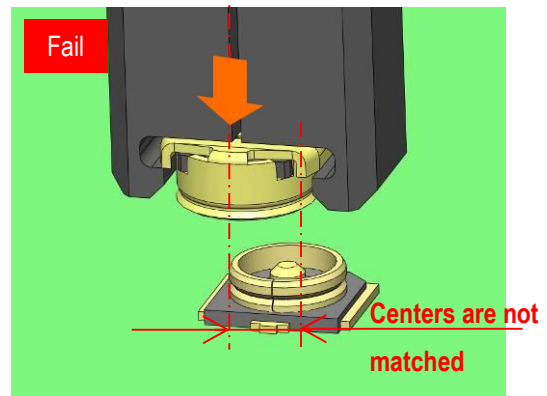
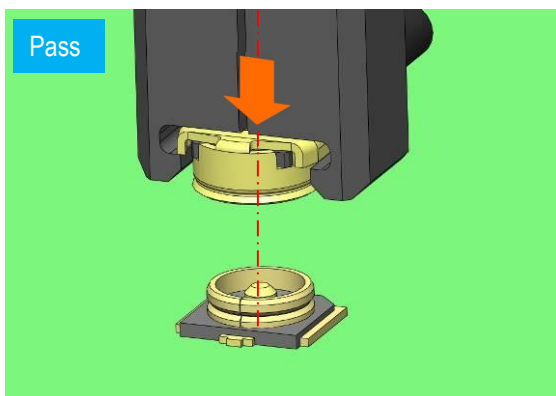

STEP4 : After released the jig, slide the jig to the cable side and remove it from the plug.

*To avoid touching any mounted parts, slide the jig by about 2mm to the cable side.

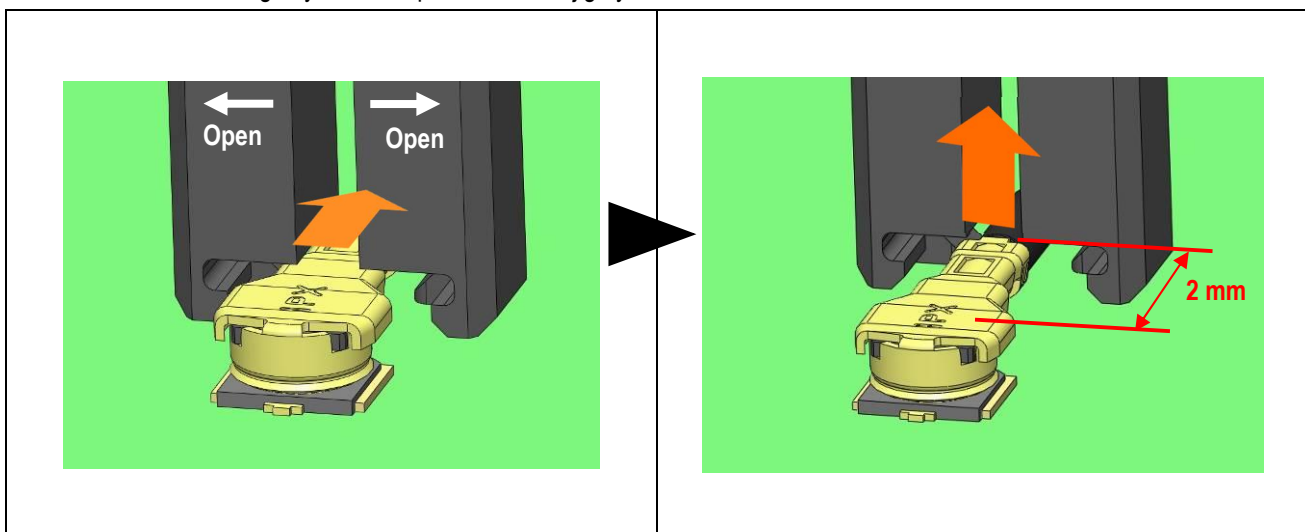

4.2 Unmating plug

STEP1 : Paying attention to the jig direction (see the clause 3 “Cautions in use”), set the jig so that the cable comes between the barrel holding part.

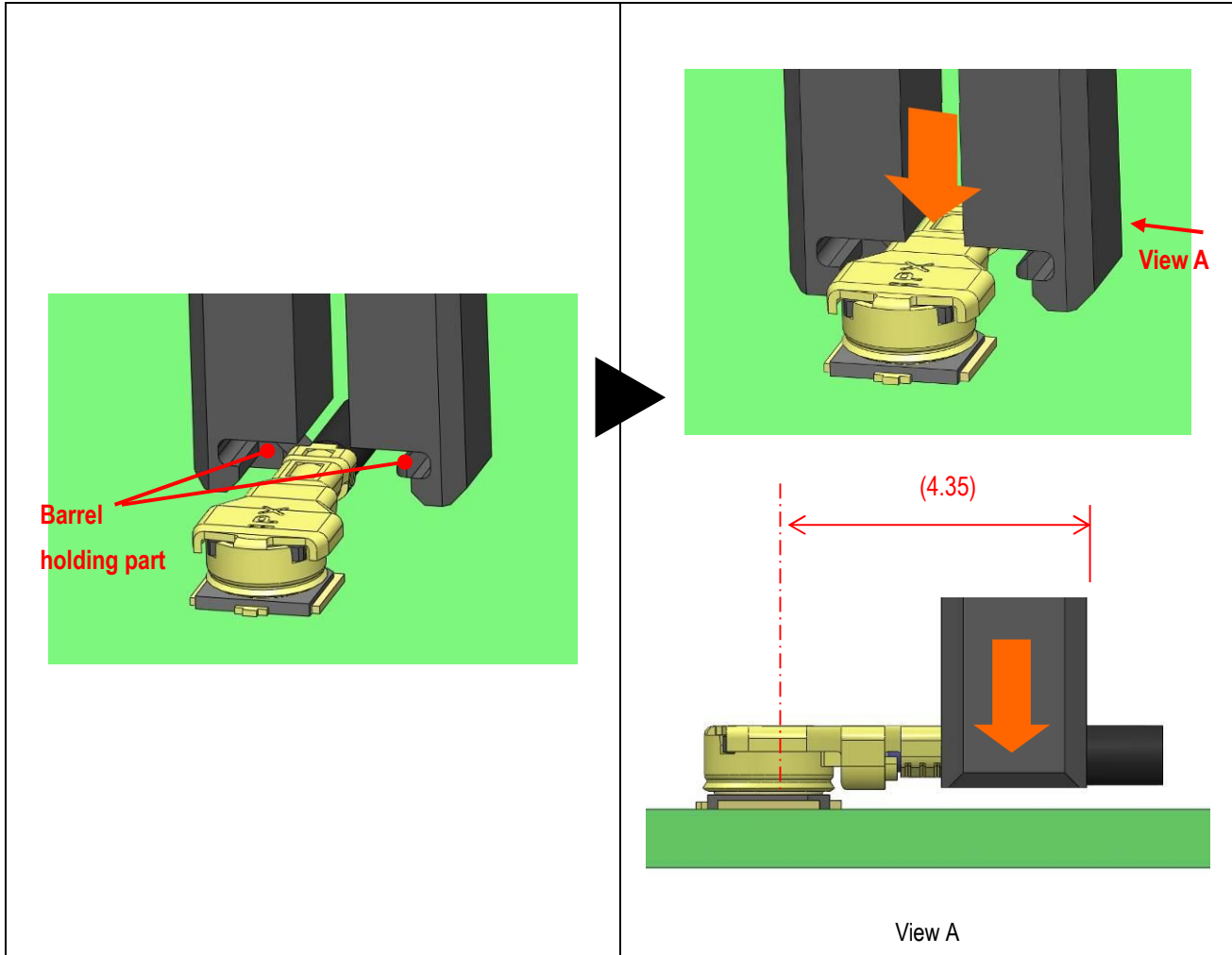

STEP2 : Closing the jig lightly, slide it to the end over the plug.

(Paying attention to the caution① in the clause 4-1 STEP2, slide the jig to the proper position.)

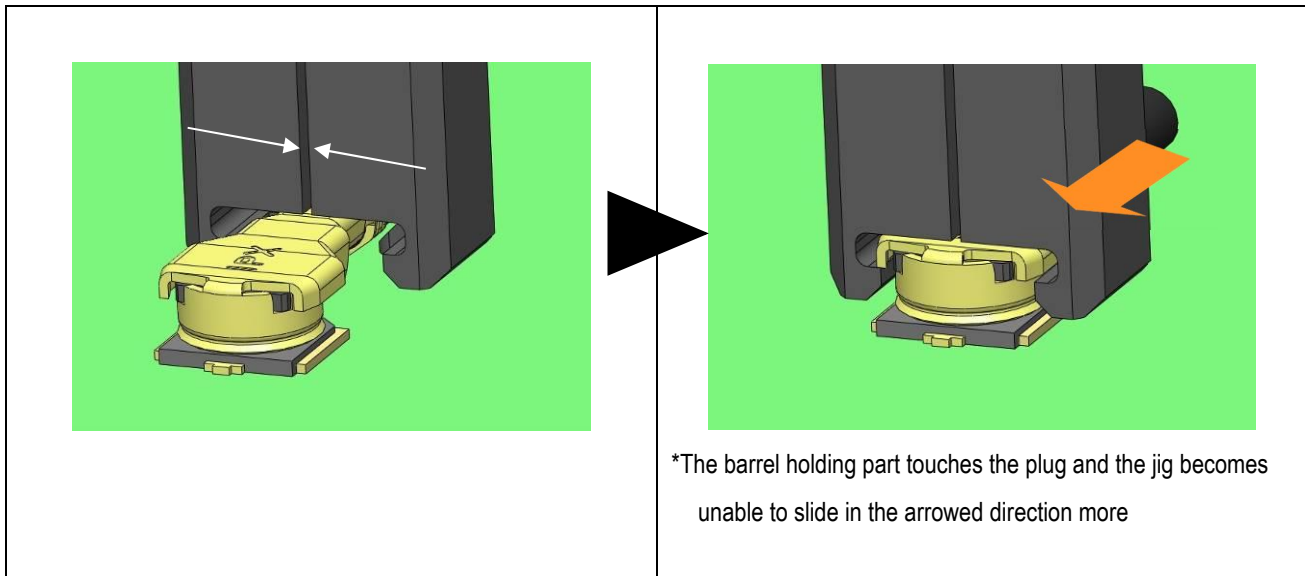

STEP3 : Clip the plug and pull the jig vertically from the receptacle to unmating plug.

