

LIGHTPASS™-EOM 100G Evaluation Board

Part No. 88001-000T-25-01

Instruction Manual

0	S21539	October 27, 2021	S.Arai	K.Nishiyama	Y.Hashimoto
Rev.	ECN	Date	Prepared by	Checked by	Approved by

1. Evaluation Board for LIGHTPASS™-EOM 100G

The set of evaluation boards are as follows

- LIGHTPASS™-EOM 100G
- LIGHTPASS™-EOM 100G mounting evaluation board + control board
- I2C control cable (connect to PC and power supply)

Please check the contents.

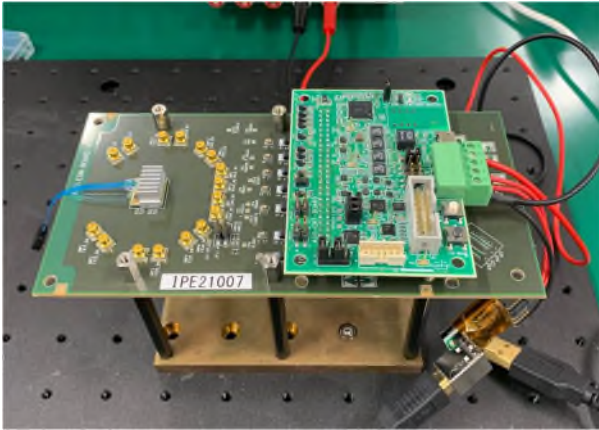

2. I2C Cable Specification (Using an external power supply)

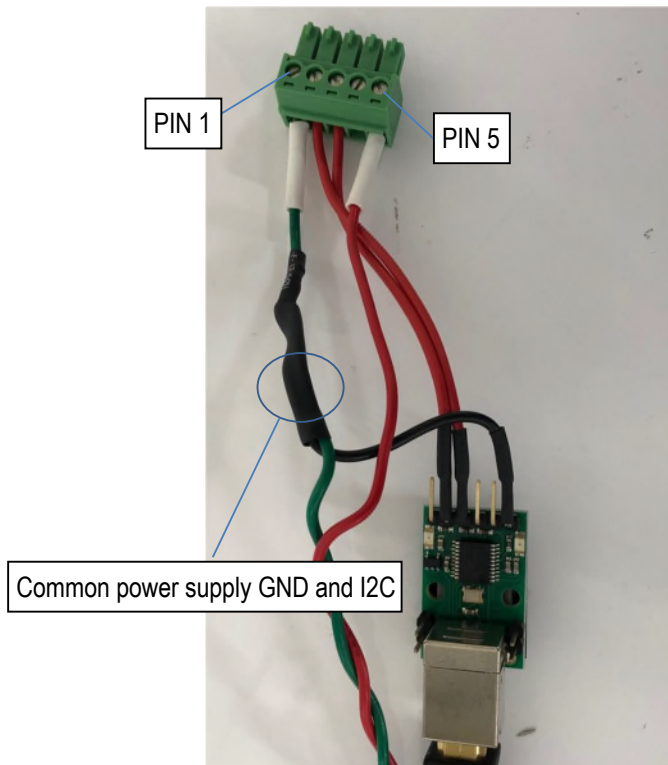

※ Please connect with an external power supply
(Do not connect USB 5V)

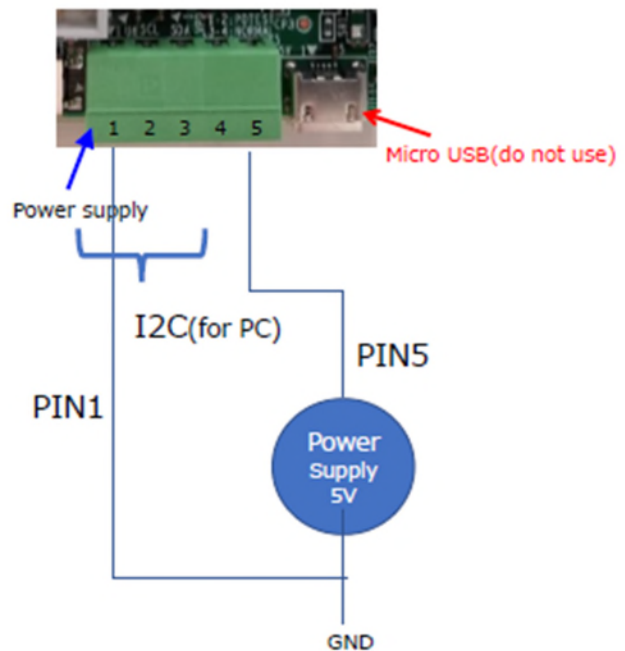

3. Reference Set up (Loop-back)

- It's outline loopback evaluation.
- Please prepare the parts shown in red at your company.

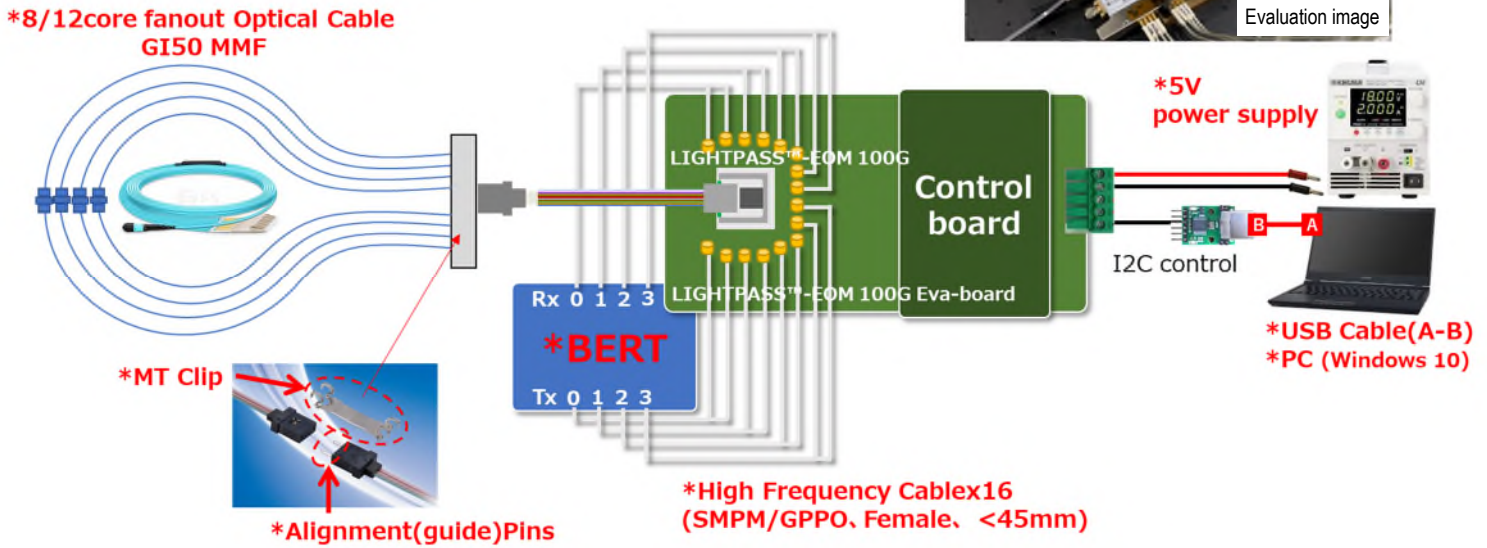
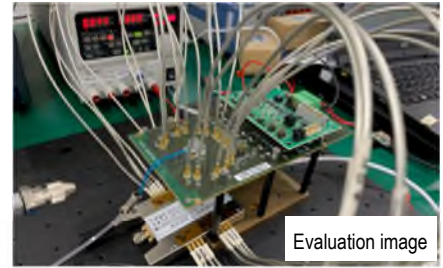

4. Reference) Removal and installation of LIGHTPASS™-EOM 100G

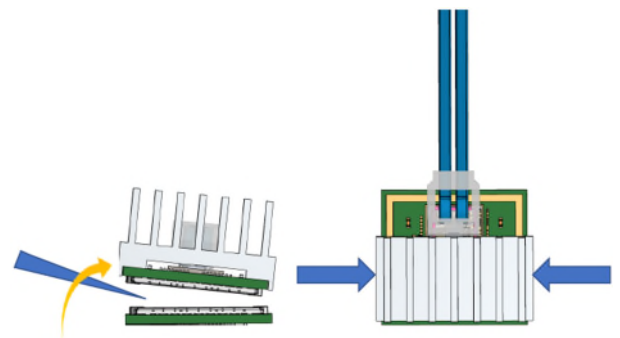
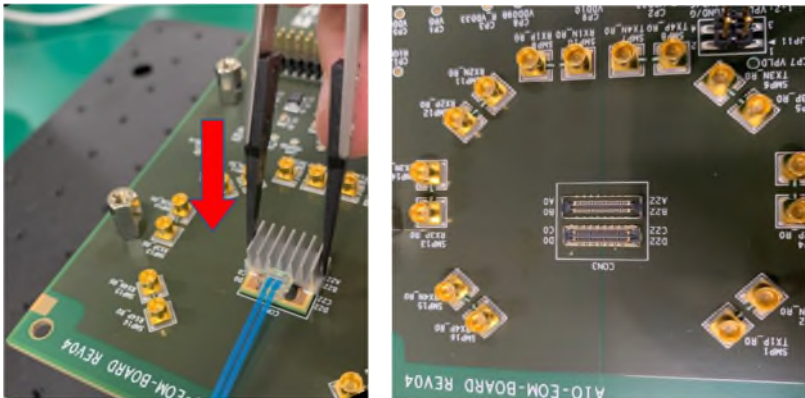

When removing the LIGHTPASS™-EOM 100G, in parallel with the electric socket.

(Do not hold the heat sink and pull it up)

When inserting the LIGHTPASS™-EOM 100G, you can press the entire heat sink.

Use the white line on the board as a guide and insert until you feel a click.

5. Reference) Optical Fiber Connection

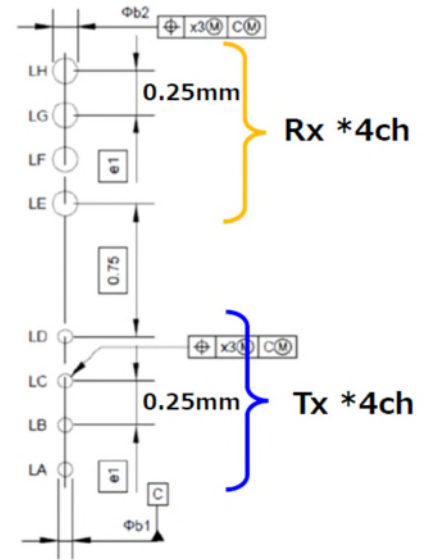
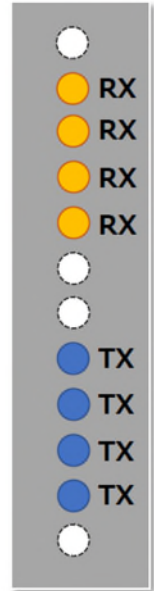
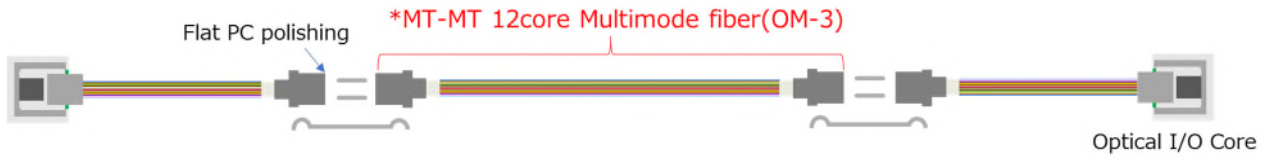

MT ferrule