

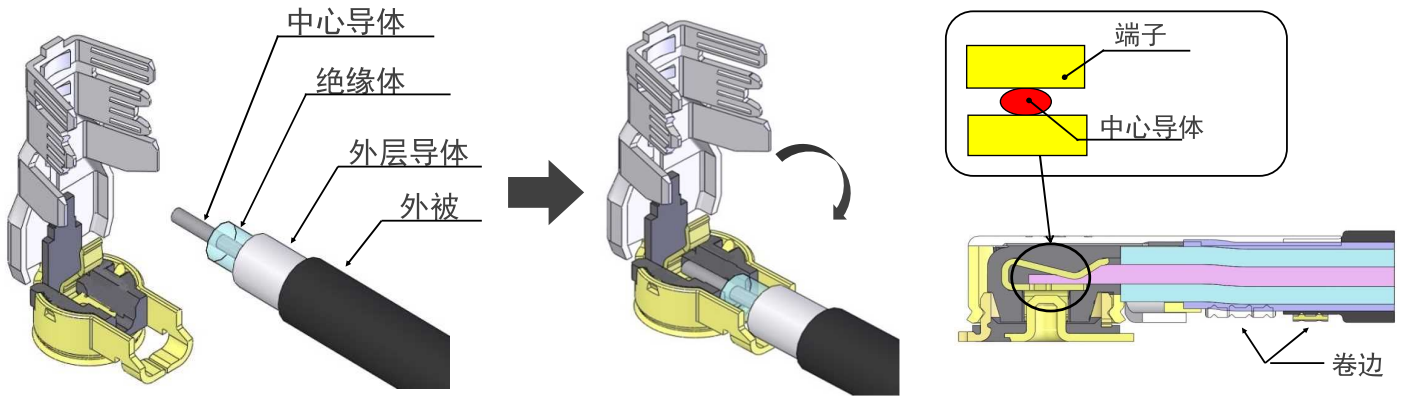

- ✓使用 “i-Fit[®]” 技术的无需焊接极细同轴线连结
- ✓与外径 2.0 mm 的极细同轴线的搭配使用，能实现低插入损耗
- ✓2.0 mm 外径 (AWG #26) 的极细同轴线公座可匹配标准 MHF I 母座

Se		3.0	
Outside dimension of receptacle(mm)		3.1 x 3.0	
Applicable wire gauge		O.D. 1.80 / 1.37 mm / AWG 30 O.D. 1.32 / 1.13 mm / AWG 32 O.D. 0.81 mm / AWG 36	
Frequency		DC~9 GHz	
Connector		PLUG	RECE
VSWR (L=100 mm)	DC~3 GHz	1.3 max.	1.3 max.
	3 GHz~6 GHz	1.5 max.	1.4 max.
	6 GHz~9 GHz	1.9 max.	1.8 max.
Service temp. (Celsius)		-40 degree ~ +90 degree	
Characteristic impedance		50 ohm	
Rated voltage		AC60V	
Contact resistance		20m ohm max.	
Withstand voltage		AC200V/min	
Insulation resistance		500M ohm min./DC100V	

使用 “i-Fit[®]” 技术的无需焊接极细同轴线连结



与外径 2.0 mm 的极细同轴线的搭配使用，能实现低插入损耗

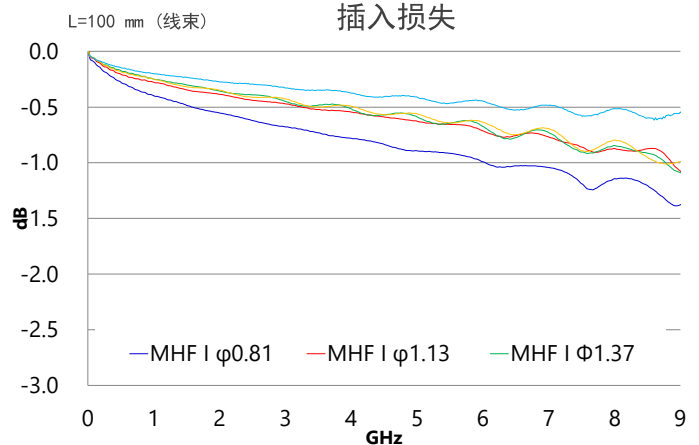
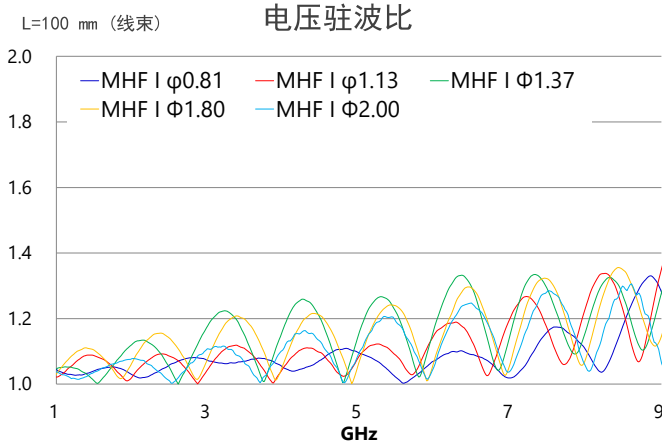

外径 2.0 mm (AWG #26) 的极细同轴线公座，可匹配标准的 MHF I 母座

同轴线外径 (中心导体 AWG)	组合高度	
	最大 3.0 mm	最大 2.5 mm MHF I LK 最大 2.9 mm
2.00 mm (26)	○	
1.80 mm (30)		○
1.37 mm (30)		○
1.32 mm (32)		○
1.13 mm (32)		○
0.95 mm (33)		
0.81 mm (33)		
0.81 mm (36)		○
0.64 mm (36)		
0.48 mm (38)		
母座	MHF I/II 母座	

MHF[®] I (2.0 mm Cable O.D.) Component Parts Detail

MHF[®] I plug (2.0 mm Cable O.D.)

Recommended P/N	20767-001R-20
PART No.	
20767-001R-20	

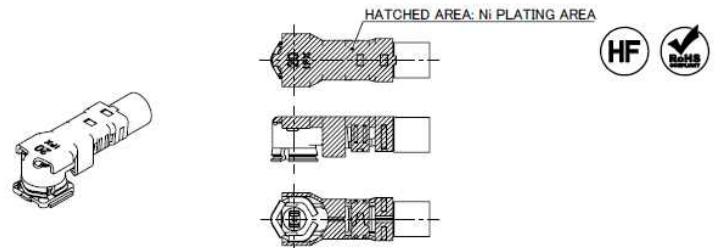
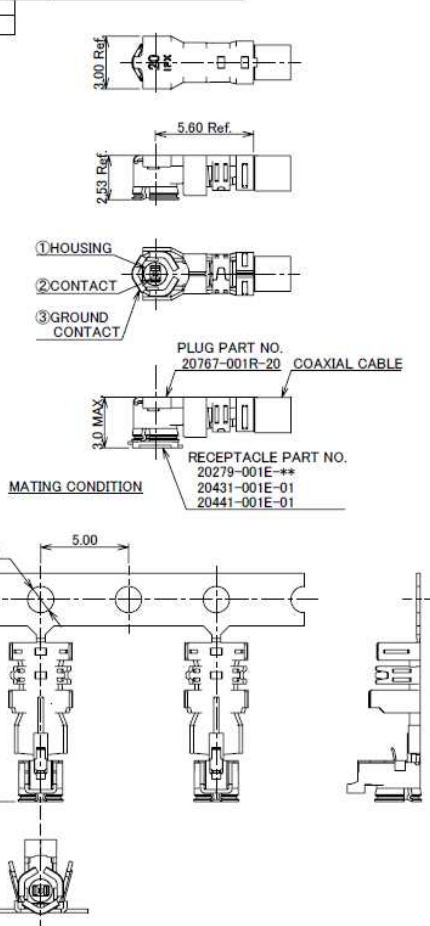

NOTES

- APPLICABLE CONNECTOR:
20279-001E-**, 20431-001E-01, 20441-001E-01
- MATING AND UNMATING INSTRUCTION
 - MATING
MATE THE CONNECTOR VERTICALLY AS MUCH AS POSSIBLE, ADJUSTING THE MATING AXIS OF PLUG AND RECEPTACLE. DO NOT SLANT MATE.
 - UNMATING
 - IN CASE OF UNMATING BY PULLING TOOL (PART NO. 90885-0001)
USE THE PULLING TOOL AS THE FOLLOWING DRAWING, AND PLEASE PULL PLUG TO VERTICAL DIRECTION AS DIRECTLY AS POSSIBLE.
 - IN CASE OF UNMATING DIRECTLY BY HAND
CATCH THE CATCHING AREA OF PLUG, AND PULL PLUG TO VERTICAL DIRECTION AS DIRECTLY AS POSSIBLE.

NOTES 2-1.

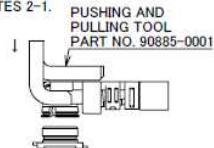

NOTES 2-2-1.

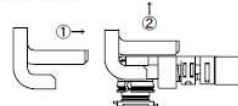

NOTES 2-2-2.

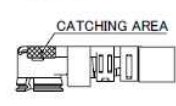

3	GROUND CONTACT	PHOSPHOR BRONZE	ALL OVER Ni 1.00 μm MIN. CONTACT PART Au 0.05 μm MIN.
2	CONTACT	PHOSPHOR BRONZE	ALL OVER Ni 1.00 μm MIN. CONTACT PART Au 0.10 μm MIN.
1	HOUSING	PBT	UL94V-0, BLACK
NO.	DESCRIPTION	MATERIAL	FINISH, REMARKS

MHF® I plug (2.0 mm Cable O.D.)

ITEMS	SPECIFICATION
RECOMMENDED APPLICABLE CONNECTOR PART No.	20279-001E-**-**
RATING VOLTAGE	60 V AC (R.M.S)
RATING FREQUENCY	DC~9GHz
OPERATING TEMPERATURE	233~363 K (-40°C~+90°C)
VSWR	1.3 MAX. AT 0.1~3 GHz, 1.5 MAX. AT 3~6 GHz, 1.6 MAX. AT 6~9 GHz
MAIN CONTACT RESISTANCE	INITIAL: 20 mohm MAX. / AFTER TEST: Δ R 20 mohm MAX.
GROUND CONTACT RESISTANCE	INITIAL: 20 mohm MAX. / AFTER TEST: Δ R 100 mohm MAX.
INSULATION RESISTANCE	INITIAL: 500 Mohm MIN. / AFTER TEST: 100 Mohm MIN.
DIELECTRIC WITHSTANDING VOLTAGE	200 V AC, 1 MINUTE
DURABILITY	30 CYCLES
UNMATING FORCE (INITIAL / AFTER TEST)	5 N MIN. / 3 N MIN.
CRIMP STRENGTH	15 N MIN.
PRODUCT SPECIFICATION	PRS-2490
TEST REPORT	TR-18041
PACKING STANDARD	PST-16007
INSTRUCTION MANUAL	HIM-17017
APPEARANCE CRITERIA No.	QLS-A***

Rev.2

MHF® I plug (2.0 mm Cable O.D.)

PART NO.	20767-001R-20		
APPLICABLE CABLE NOMINAL DIMENSION			
BRAIDED SHIELD OF OUTER CONDUCTOR	SINGLE		
PART NO. OF SEMI AUTO TERMINATION MACHINE	90876-020		
CRIMP HEIGHT	CH-1 i-Fit® PART	CH-2 SHIELD PART	CH-3 JACKET PART
	2.28~2.36	1.81~1.87	1.95~2.01

Rev.2

Accessories for MHF® I plug (2.0 mm Cable O.D.)



MHF I/II SMA ADAPTOR
PART NO. 90193-001



MHF I/II PLUG INSPECTION CONNECTOR
PART NO. 90194-001

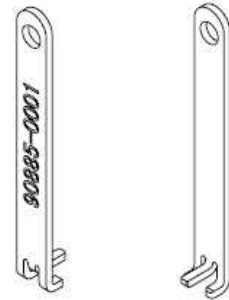

FRONT SIDE BACK SIDE
MHF I PLUG (2.00) PUSHING AND PULLING TOOL
PART NO. 90885-0001

Rev.2

MHF® I Receptacle

Recommended P/N		20279-001E-03
PART NO.	PACKING REEL	QUANTITY IN 1 REEL
20279-001E-01	PLASTIC REEL	2,500
	CORRUGATED PAPER REEL	2,500
20279-001E-03	PLASTIC REEL	5,000
20279-001E-05	PLASTIC REEL	10,000

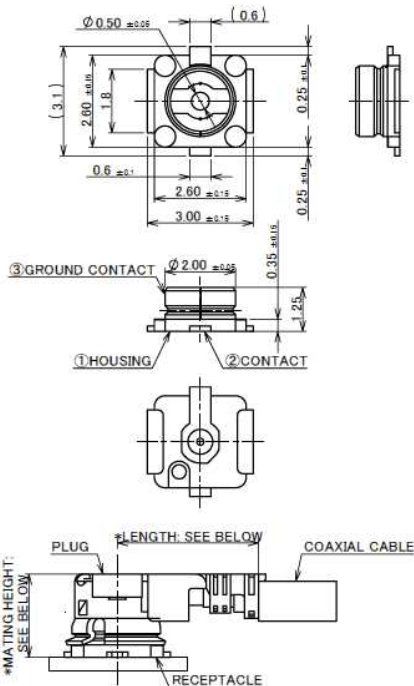

- NOTES
- APPLICABLE CONNECTOR PART NO.
MHF I PLUG
20278-11R-**-**
20351-***R-37
20631-***R-**-**
20670-001R-**-**
20767-001R-20
MHF II PLUG
20311-011R-**-**
20686-001R-08
 - COPLANARITY: 0.1mm MAX.
 - THIS IS "Pb-FREE" CONNECTOR.

NO.	DISCRIPTION	MATERIAL	FINISH, REMARKS
3	GROUND CONTACT	PHOSPHOR BRONZE	ALL OVER Ni 1.00 μm MIN. CONTACT PART Au 0.05 μm MIN. SOLDERING PART Au 0.05 μm MIN.
2	CONTACT	BRASS	ALL OVER Ni 1.00 μm MIN. CONTACT PART Au 0.10 μm MIN. SOLDERING PART Au 0.03 μm MIN.
1	HOUSING	LCP	UL94V-0, WHITE

*LENGTH: 4.0 ± 0.4 AT PLUG PART NO. 20670-001R-08, 20670-001R-13, 20670-001R-32
4.7 ± 0.4 AT PLUG PART NO. 20670-001R-18, 20670-001R-37
5.6 AT PLUG PART NO. 20767-001R-20 (REFERENCE DIMENSION)
3.8 ± 0.3 AT PLUG PART NO. 20686-001R-08, 20311-011R-**-**
*MATING HEIGHT: 2.5 MAX. AT PLUG PART NO. 20670-001R-**-**
3.0 MAX. AT PLUG PART NO. 20767-001R-20
2.0 ± 0.1 AT PLUG PART NO. 20686-001R-08, 20311-011R-**-**
MATING CONDITION

Rev.25

MHF® I Receptacle

ITEMS	SPECIFICATION		
	20670-001R-**- (MHF I PLUG Ni TOP 1.80, 1.37, 1.32, 1.13, 0.81)	20767-001R-20 (MHF I PLUG 2.00)	20686-001R-08 (MHF II PLUG Ni TOP 0.81)
RECOMMENDED APPLICABLE CONNECTOR PART NO.			
RATING VOLTAGE	60 V AC (R.M.S)		
RATING FREQUENCY	DC~9GHz		
OPERATING TEMPERATURE	233~383K (-40°C~+90°C)		
VSWR	RECEPTACLE: 1.3 MAX. AT 0.1~3 GHz, 1.4 MAX. AT 3~6 GHz, 1.8 MAX. AT 6~9 GHz		
MAIN CONTACT RESISTANCE	INITIAL: 20 mohm MAX. / AFTER TEST: ΔR 20 mohm MAX.		
GROUND CONTACT RESISTANCE	INITIAL: 20 mohm MAX. / AFTER TEST: ΔR 100 mohm MAX.		
INSULATION RESISTANCE	INITIAL: 500 Mohm MIN. / AFTER TEST: 100 Mohm MIN.		
DIELECTRIC WITHSTANDING VOLTAGE	200 V AC, 1 MINUTE		
DURABILITY	30 CYCLES		
UNMATING FORCE (INITIAL / AFTER TEST)	INITIAL: 5 N MIN. AFTER TEST: 3 N MIN.		INITIAL: 4 N MIN. AFTER TEST: 2 N MIN.
PRODUCT SPECIFICATION	PRS-2105	PRS-2490	PRS-2106
TEST REPORT	TR-15059	TR-18041	TR-15060
PACKING STANDARD	20279-001E-01: 300-232 (CORRUGATED PAPER REEL) PST-12002 (ANTI-STATIC PLASTIC REEL) 20279-001E-03: 300-850 20279-001E-05: PST-13040		
INSTRUCTION MANUAL	HIM-10002		HIM-12010
APPEARANCE CRITERIA No.	QLS-A***		

※UNLESS OTHERWISE SPECIFIED, 20279-001E-01 WILL DERIVED IN CORRUGATED PAPER REELS.
CONTACT YOUR I-PEX SALES IF YOU WISH FOR PLASTIC REELS.

Rev.25

MHF® I Receptacle

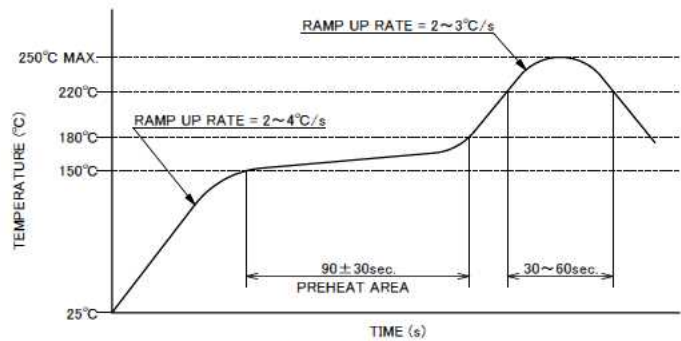
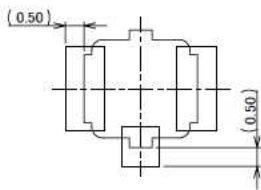
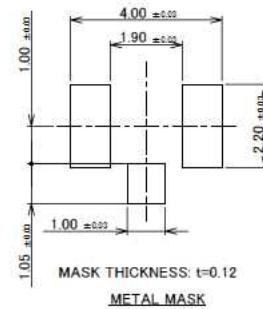
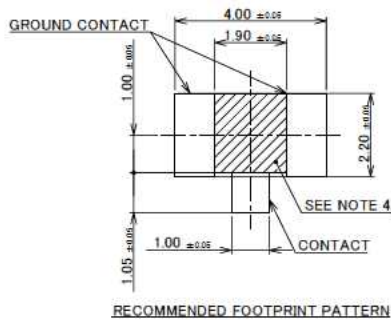

NOTES
4. CUT OUT PROHIBITION AREA

Rev.25

Accessories for MHF® I Receptacle



MHF I/II SMA ADAPTOR
PART NO. 90193-002



4.5MM HIGH CYCLE TEST PROBE FOR MHF/MHF A
PART NO. 90575-0001

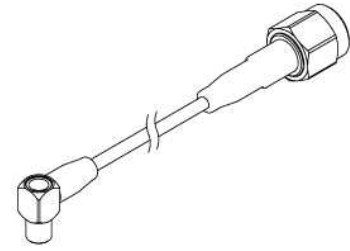

4.5MM HIGH CYCLE TEST PROBE CABLE ASS'Y
PART NO. 90577-****

* 90575-0001 AND 90577-**** SHOULD BE USED TOGETHER.

Rev.25

I-PEX

Copyright © I-PEX Inc. 2020. All rights reserved.

I-PEX, MHF, CABLINE, NOVASTACK, EVAFLEX, MINIFLEX, ISH, IARPB, IASLP, ESTORQ, i-Fit 以及 ISFIT 是 I-PEX 株式会社的注册商标。请注意，目录中的内容可能会在没有事先通知的情况下进行更改。I-PEX 集团没有义务和责任承担这些文件中误差和更新。使用我们的产品前，请务必正确阅读和理解最新的“使用注意事项”和“使用说明书”。如果您在使用我们的产品时没有遵循使用注意事项，我们将不对任何不良、损坏或故障负责。当您我们的产品使用在任何需要较高可靠性和安全性，或者涉及生命安全的应用时，请提前联系我们的销售代表。（例如：核电控制，航空航天，运输，医疗设备，安全设备等）

请联系您当地的销售代表，了解更详细的信息 [i-pex.com]

202008R0