

MHF[®] 4L

M.2 규격 표준 Connector: 결합높이 1.2 mm, 1.4 mm, 1.7mm max., ~ 12 GHz 주파수에 우수한 전송특성을 발휘

Product Specifications:

Mated Height (mm max.)	(1) 1.2, (2) 1.4, (3) 1.7		
Rece. SMT Size (mm)	2.0 x 2.0		
Applicable Frequency	DC ~ 12 GHz		
Characteristic Impedance	50 ohm		
VSWR (L=100 mm)	Connector	PLUG	RECEPTACLE
	DC ~ 3 GHz	1.3 max.	1.3 max.
	3 ~ 6 GHz	(1)(2) 1.45 max. (3) 1.4 max.	1.4 max.
	6 ~ 9 GHz	(1)(2) 1.6 max. (3) 1.5 max.	1.5 max.
	9 ~ 12 GHz	(1)(2) 1.9 max. (3) 1.6 max.	1.65 max.

* Cable size O.D. (1) 0.81 mm, 0.64 mm (2) 1.13 mm, 0.95 mm (3) 1.37 mm

Applicable Cable Size:

- (1) 20572-001R-08
O.D. 0.81 mm, O.D. 0.64 mm / AWG 36
- (2) 20565-001R-13
O.D. 1.13 mm / AWG 32
O.D. 0.95 mm / AWG 33
- (3) 20632-001R-37
O.D. 1.37 mm / AWG 30

Applicable Standards (Reference Only):

- 5G sub-6, Wi-Fi 6E, LTE/LTE-Advanced, LPWA, Bluetooth, GPS



▶ **최소한의 제품 사이즈로 ~ 12GHz에서 우수한 퍼포먼스를 실현**

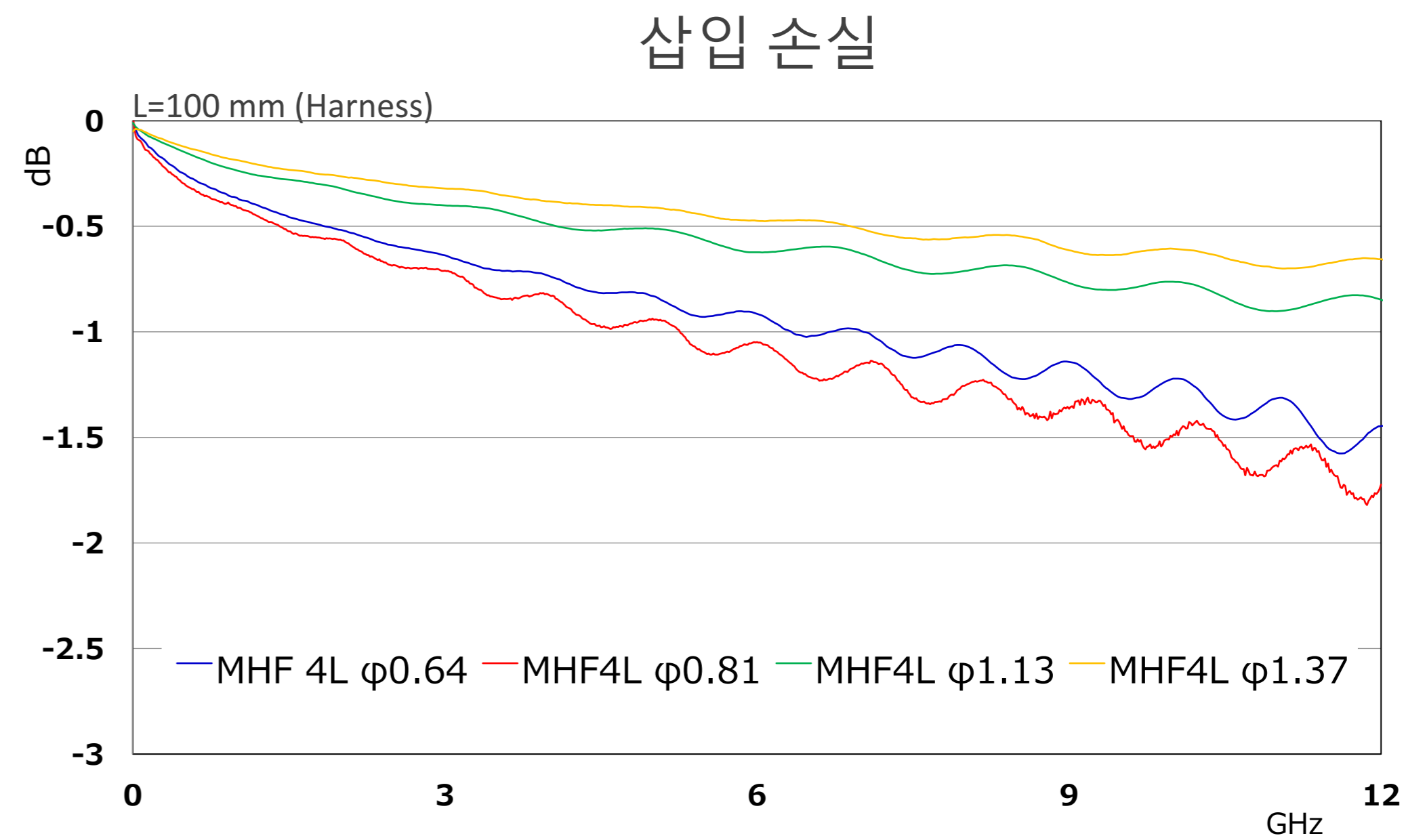
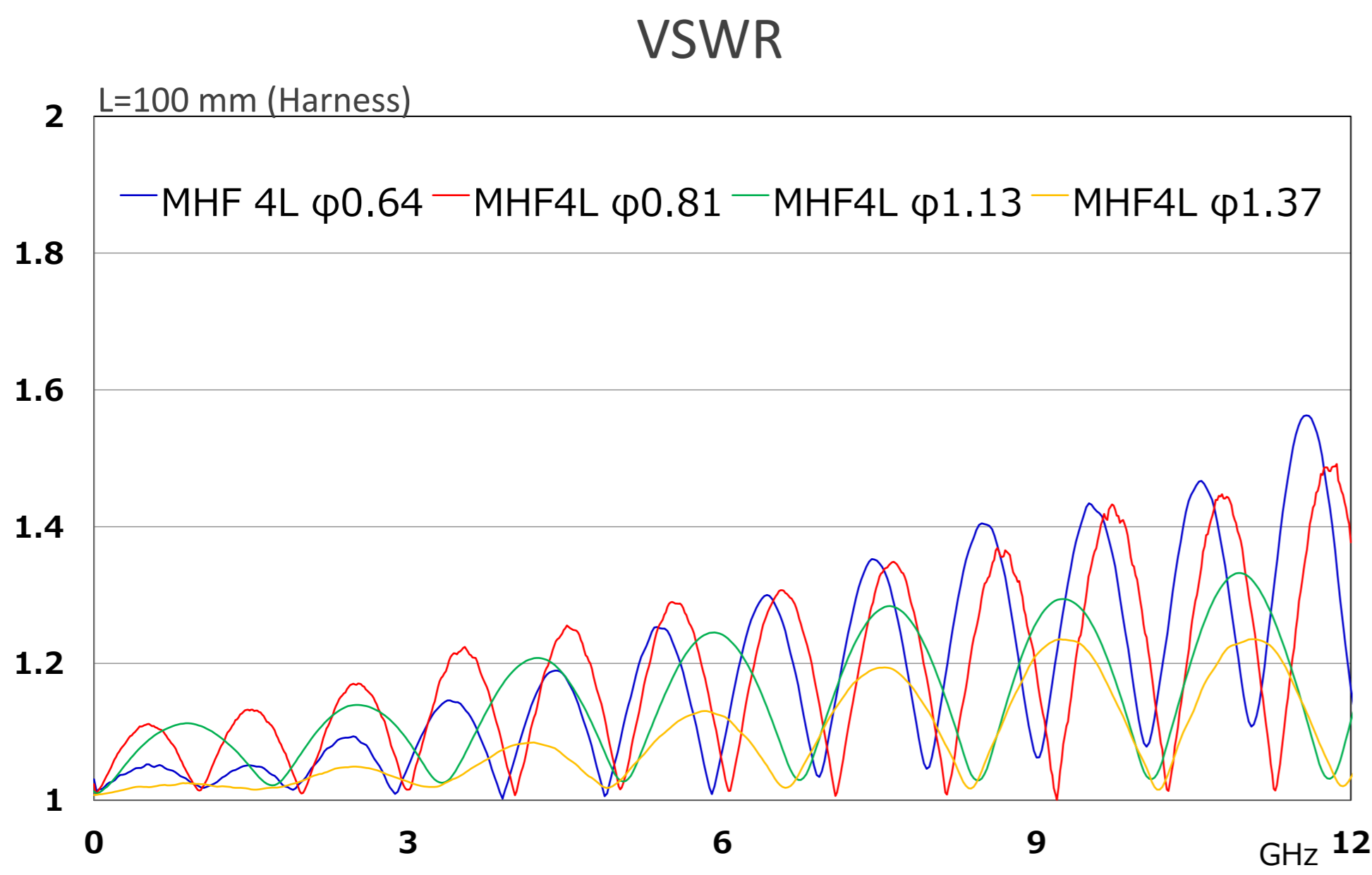

▶ **신뢰성 높은 무납땜 결선 기술 "i-Fit[®]" 테크놀러지로, 안정된 성능의 하네스 제공**

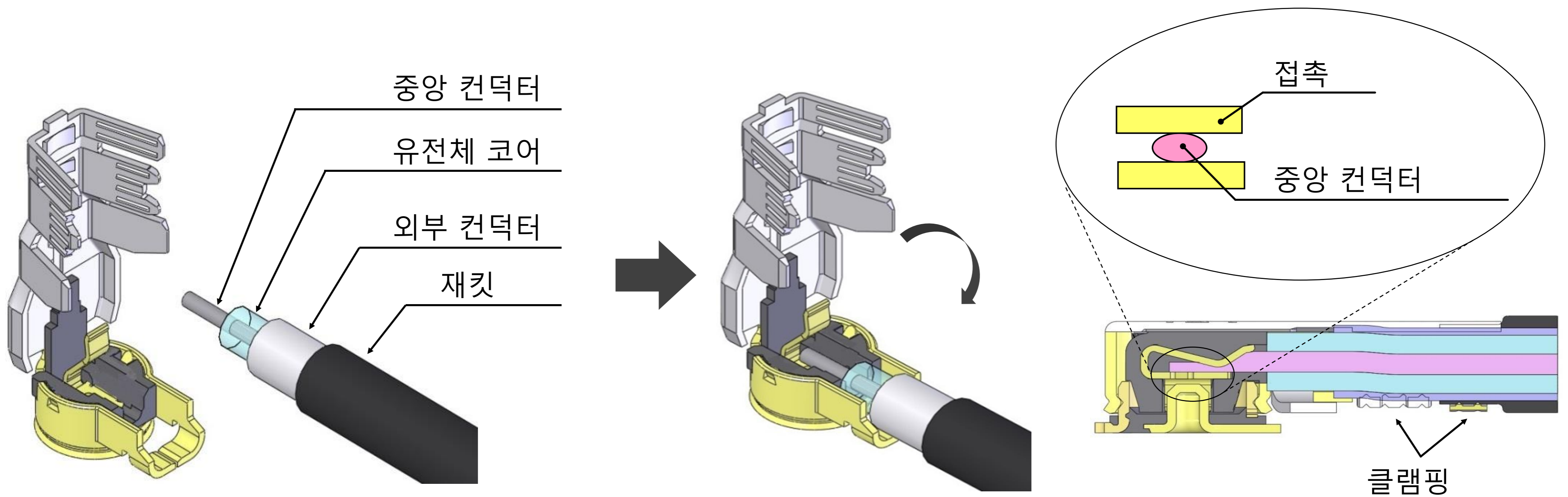

▶ **MHF[®] 4L는 다양한 케이블 직경과 기계적인 락킹 대응**

	MHF [®] 4L LK	MHF [®] 4L	MHF [®] 4L	MHF [®] 4L	
Product name	MHF [®] 4L LK	MHF [®] 4L	MHF [®] 4L	MHF [®] 4L	
Lock	With Lock	Without Lock	Without Lock	Without Lock	
Mating Height	2.0 mm max.	1.7 mm max.	1.4 mm max.	1.2 mm max.	
Coaxial O.D. (Center Conductor AWG)	1.37 mm (AWG#30)	●			
	1.13 mm (AWG#32)		●		
	0.95 mm (AWG#33)			●	
	0.81 mm (AWG#36)				●
	0.64 mm (AWG#36)				●
Receptacle	MHF [®] 4 receptacle (20449-001E-**) , MHF [®] 4L receptacle (20579-001E)				

Component Parts Details

MHF[®] 4L plug Ni top (1.37)

Recommended P/N	20632-001R-37
PART No.	20632-001R-37

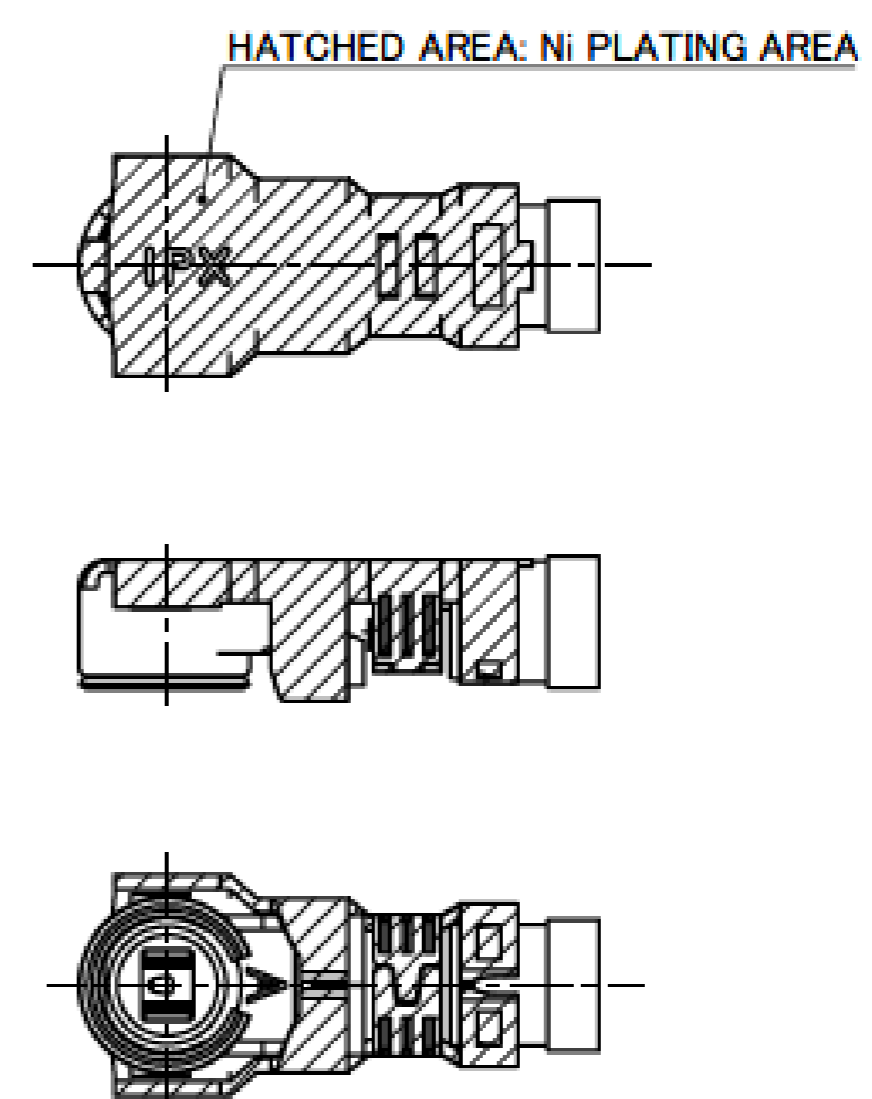
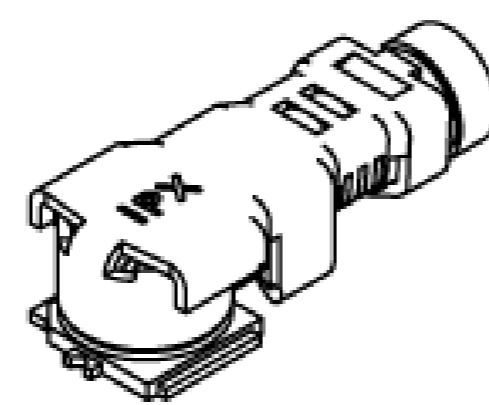
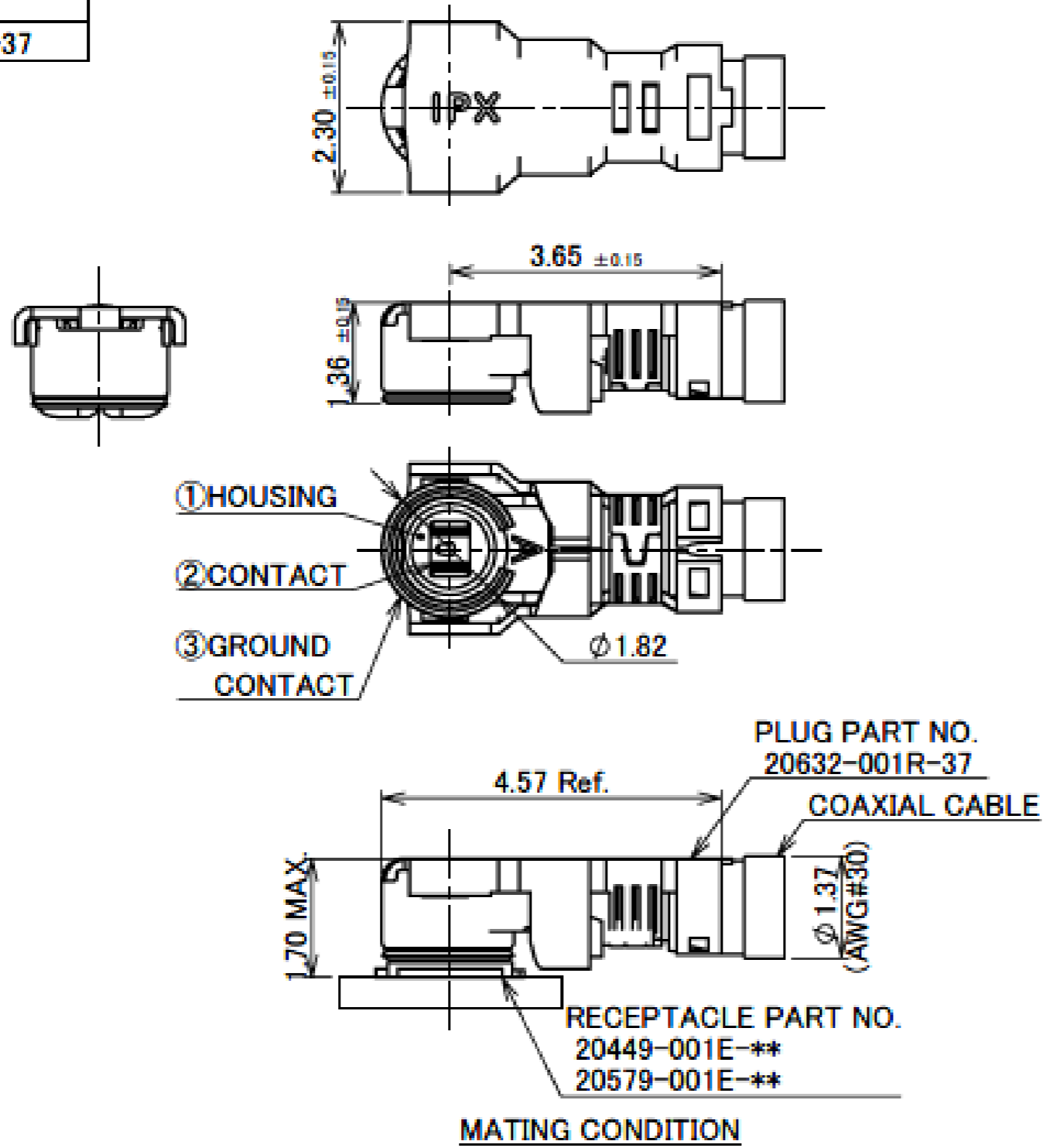

NOTES:
1. APPLICABLE CONNECTOR
20449-001E-**
20579-001E-**

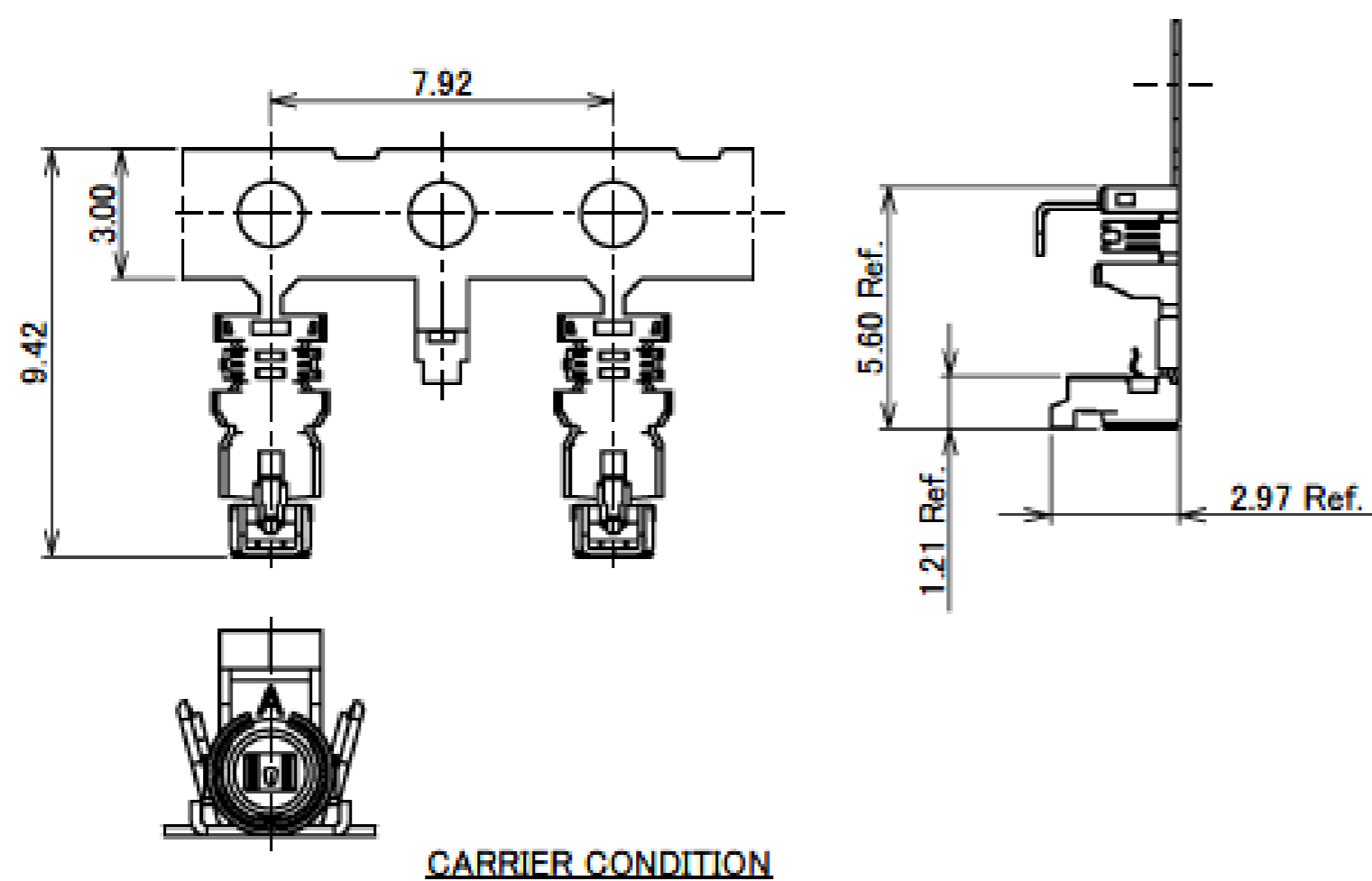

NO.	DESCRIPTION	MATERIAL	FINISH , REMARKS
3	GROUND CONTACT	PHOSPHOR BRONZE	ALL OVER Ni 1.00 μm MIN. CONTACT PART Au 0.05 μm MIN. [Ni PLATING AREA] Ni ONLY
2	CONTACT	PHOSPHOR BRONZE	ALL OVER Ni 1.00 μm MIN. CONTACT PART Au 0.10 μm MIN.
1	HOUSING	PBT	UL94V-0, BLACK (GF 10%)

MHF® 4L plug Ni top (1.37)

ITEMS	SPECIFICATION	
RECOMMENDED APPLICABLE CONNECTOR PART No.	20449-001E-**-**	20579-001E-**-**
RATING VOLTAGE	60 V AC (R.M.S)	
RATING FREQUENCY	DC~9 GHz	DC~12 GHz
OPERATING TEMPERATURE	233~363K (-40°C~+90°C)	
VSWR (MATED WITH SMA ADAPTER PART No. 90449-001)	1.30 MAX. AT 0.1~3 GHz, 1.40 MAX. AT 3~6 GHz, 1.50 MAX. AT 6~9 GHz, 1.60 MAX. AT 9~12 GHz	
MAIN CONTACT RESISTANCE	INITIAL: 20 mohm MAX. / AFTER TEST: Δ R 20 mohm MAX.	
GROUND CONTACT RESISTANCE	INITIAL: 20 mohm MAX. / AFTER TEST: Δ R 20 mohm MAX.	
INSULATION RESISTANCE	INITIAL: 500 Mohm MIN. / AFTER TEST: 100 Mohm MIN.	
DIELECTRIC WITHSTANDING VOLTAGE	200 V AC, 1 MINUTE	
DURABILITY	30 CYCLES	
MATING FORCE (INITIAL / AFTER TEST)	INITIAL: 30 N MAX. / AFTER TEST: 30 N MAX.	
UNMATING FORCE (INITIAL / AFTER TEST)	INITIAL: 20 N MAX. 5 N MIN. / AFTER TEST: 20 N MAX. 3 N MIN.	
PRODUCT SPECIFICATION	PRS-2008	PRS-2925
TEST REPORT	TR-14100	TR-24070
PACKING STANDARD	PST-12066	
INSTRUCTION MANUAL	HIM-16011	
APPEARANCE CRITERIA No.	QLS-A***	

Rev.8

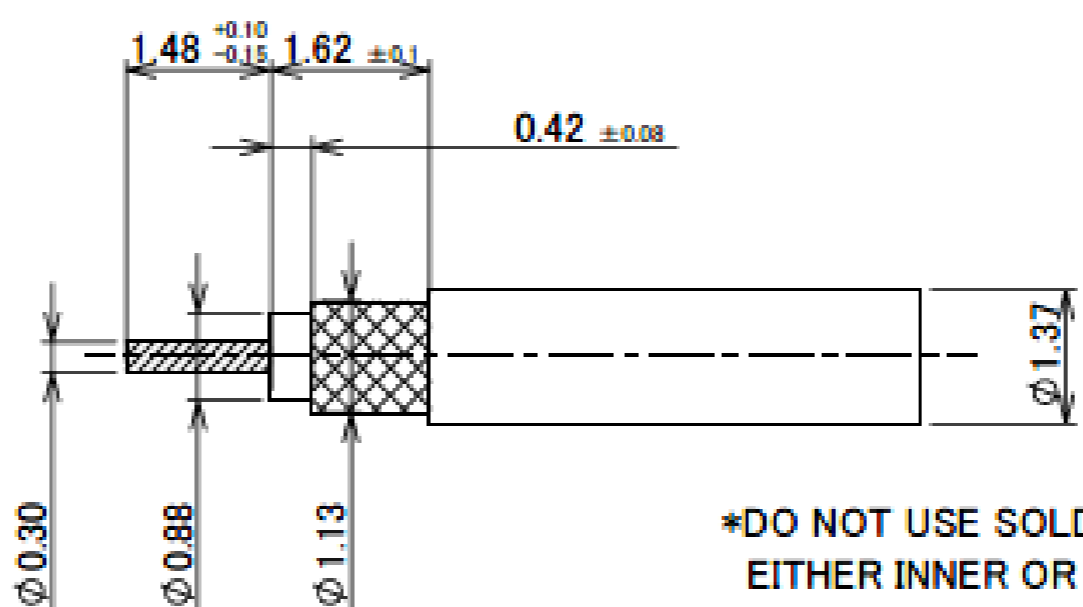
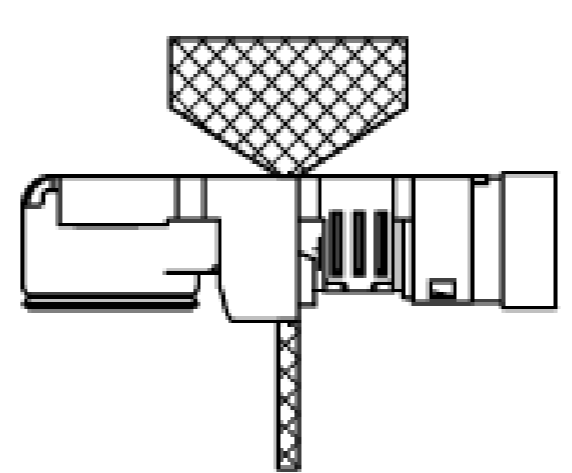
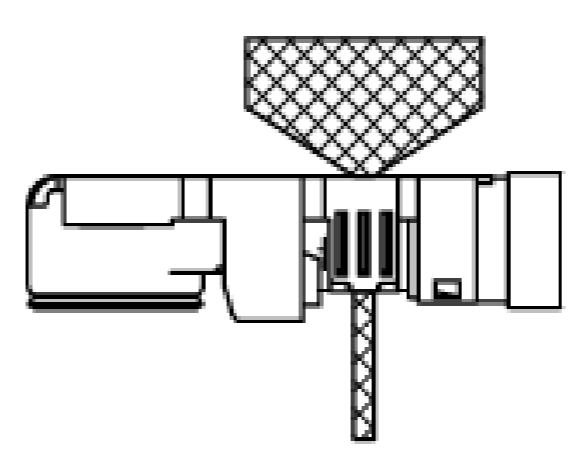
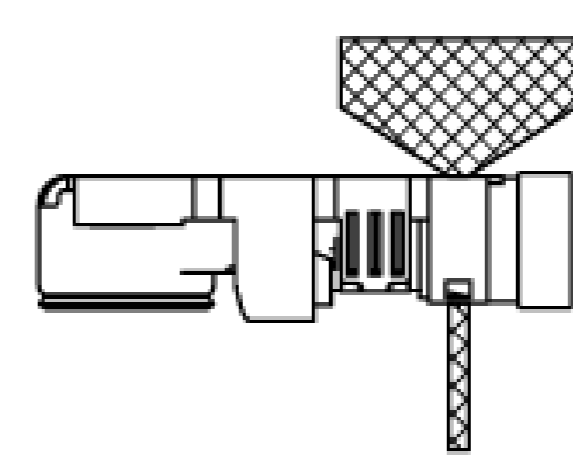
PART NO.	20632-001R-37		
APPLICABLE CABLE STRIP DIMENSION	 <p>*DO NOT USE SOLDER COATED EITHER INNER OR OUTER CONDUCTOR CABLES.</p>		
REQUIREMENTS	CHARACTERISTIC IMPEDANCE: 50(±2) ohm BY TDR METHOD NOMINAL CAPACITANCE: 98pF/m CONDUCTOR RESISTANCE OF INNER CONDUCTOR: 320 ohm/km INSULATION RESISTANCE: 1500 Mega-ohm. km MIN. DIELECTRIC WITH STANCE VOLTAGE: NO BREAKDOWN AT 1500 V AC FOR 1 MINUTE.		
BRAIDED SHIELD OF OUTER CONDUCTOR	SINGLE BRAIDED SHIELD		
PART NO. OF SEMI AUTO TERMINATION MACHINE	90703-037		
CRIMP HEIGHT	 <p>CH-1 (i-Fit® PART) 1.46~1.50</p>	 <p>CH-2 (SHIELD PART) 1.16~1.20</p>	 <p>CH-3 (JACKET PART) 1.27~1.31</p>
	※USE FOR POINT MICROMETER.		

NOTES 2.

DESCRIPTION

INNER CONDUCTOR AWG#30 (7/0.102) SILVER PLATING ANNEALED COPPER WIRE
 DIELECTRIC CORE FLUORO-PLASTICS, DIAMETER 0.88(+0.04/-0.02)mm NOMINAL THICKNESS 0.29mm
 OUTER CONDUCTOR 16/5/0.05, NOMINAL DIAMETER 1.13mm TIN-COATED ANNEALED COPPER WIRE.
 JACKET FLUORO-PLASTICS, DIAMETER 1.37±0.08mm NOMINAL THICKNESS 0.12mm

Rev.8

Accessories for MHF® 4L plug Ni top (1.37)

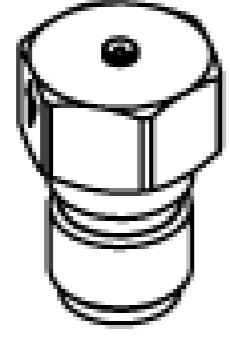

MHF 4 (4L) SMA ADAPTOR
PART NO. 90449-001

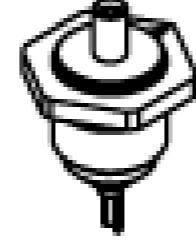

MHF 4 (4L) INSPECTION CONNECTOR
PART NO. 90449-003-01



FRONT SIDE

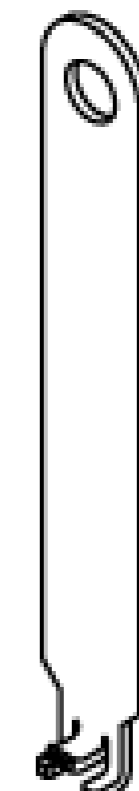

BACK SIDE

MHF 4L (1.37) PUSHING AND PULLING TOOL
PART NO. 90873-0001

Rev.8

MHF® 4L plug Ni top (1.13,0.95)

Recommended P/N	20565-001R-13
PART NO.	20565-001R-13

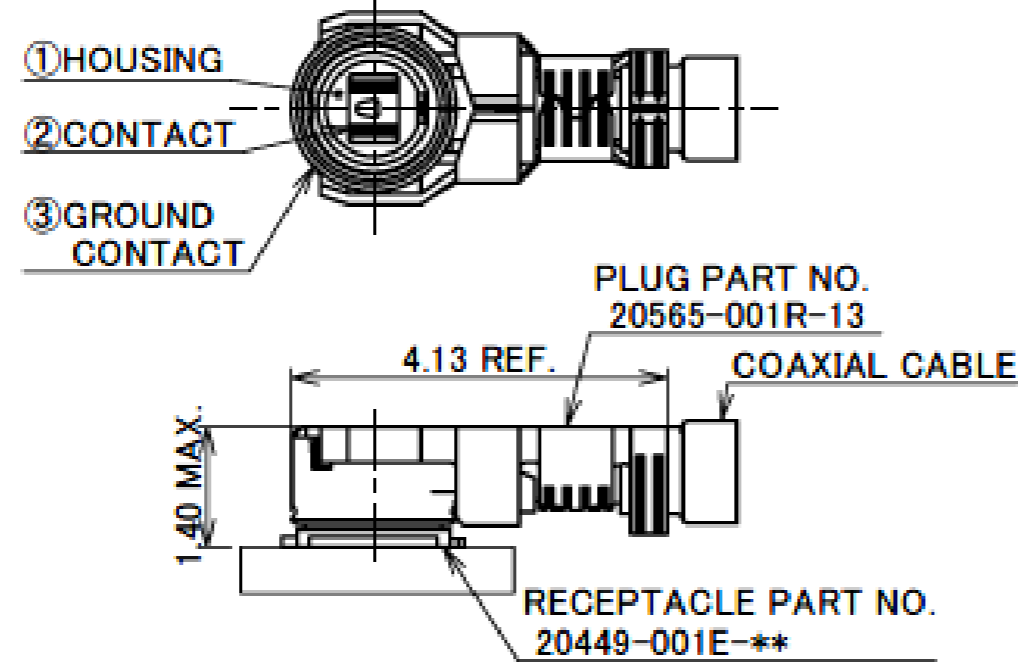
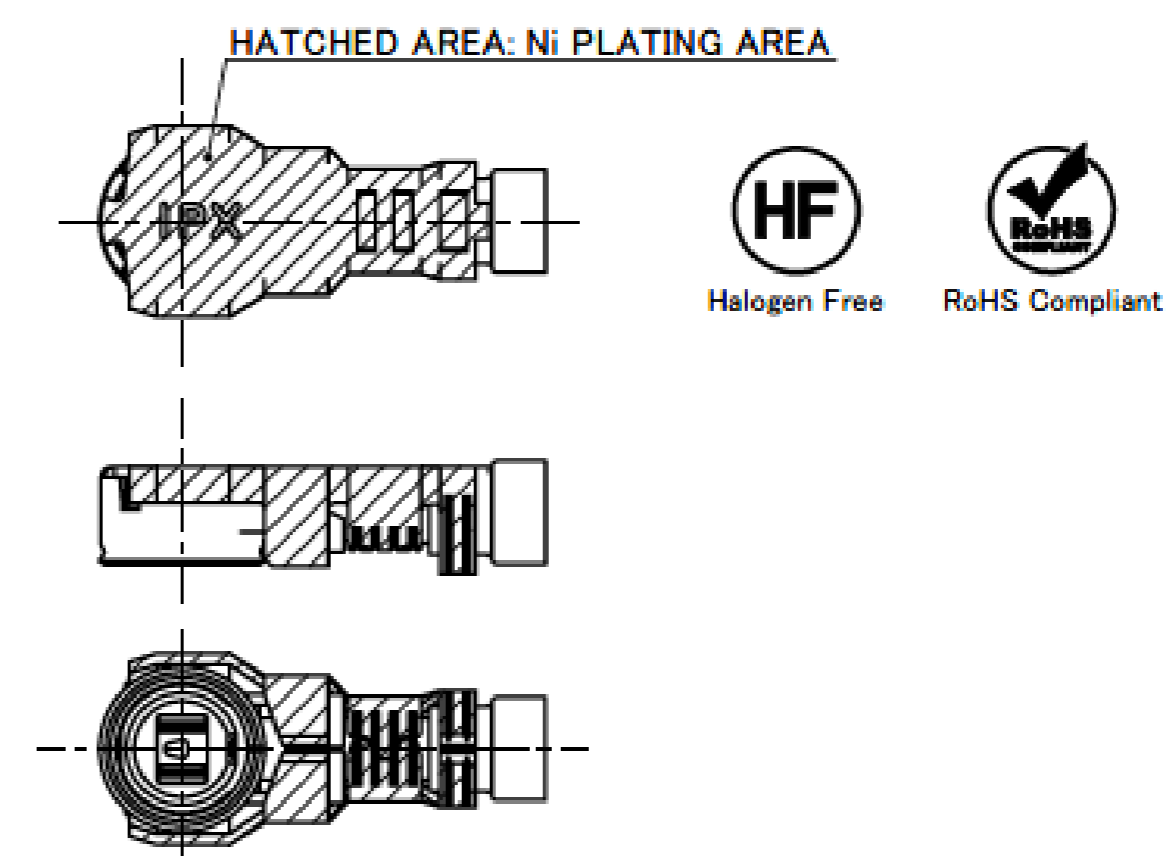
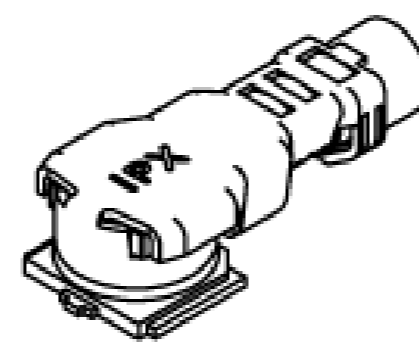
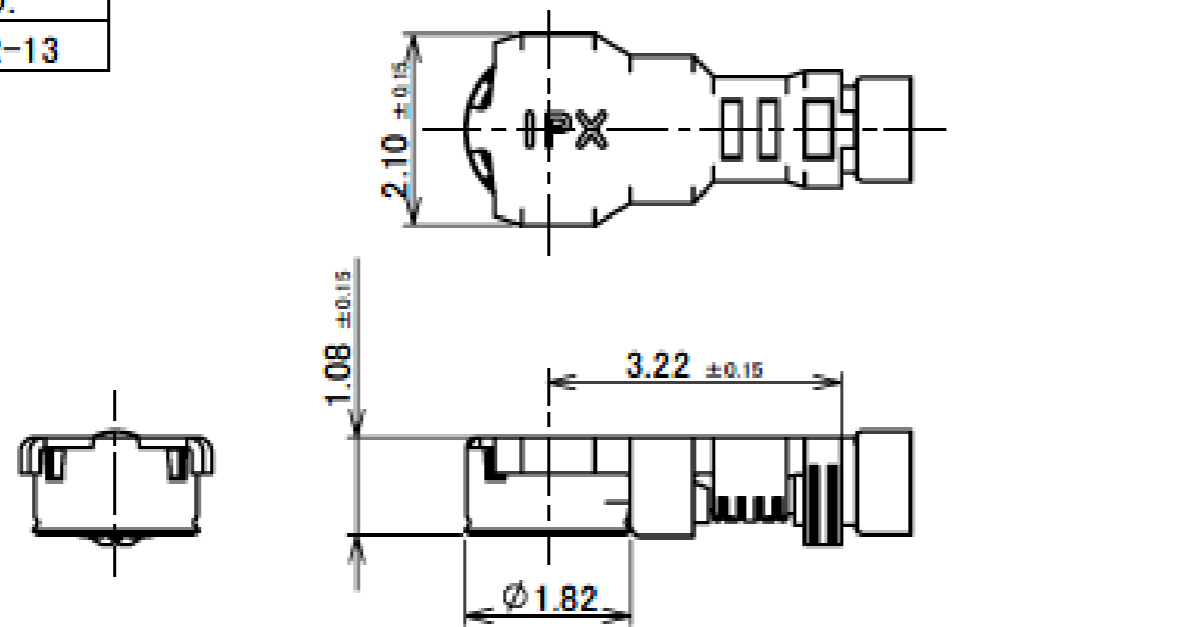

MATING CONDITION

- NOTES
- APPLICABLE CONNECTOR
20449-001E-***
20579-001E-***
 - MATING AND UNMATING INSTRUCTION
 - MATING
MATE THE CONNECTOR VERTICALLY AS MUCH AS POSSIBLE, ADJUSTING THE MATING AXIS OF PLUG AND RECEPTACLE. DO NOT SLANT MATE.
 - UNMATING INSTRUCTION
 - IN CASE OF UNMATING BY PULLING TOOL (PART NO. 90609-0001)
USE THE PULLING TOOL AS THE FOLLOWING DRAWING, AND PULL PLUG TO VERTICAL DIRECTION AS DIRECTLY AS POSSIBLE.
 - IN CASE OF UNMATING DIRECTLY BY HAND
CATCH THE CATCHING AREA OF PLUG, AND PULL PLUG TO VERTICAL DIRECTION AS DIRECTLY AS POSSIBLE.

NOTE 2-1.

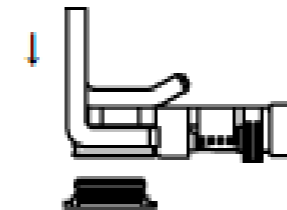

NOTE 2-2-1.

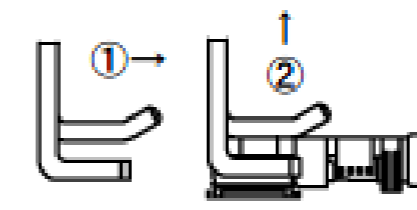

NOTE 2-2-2.

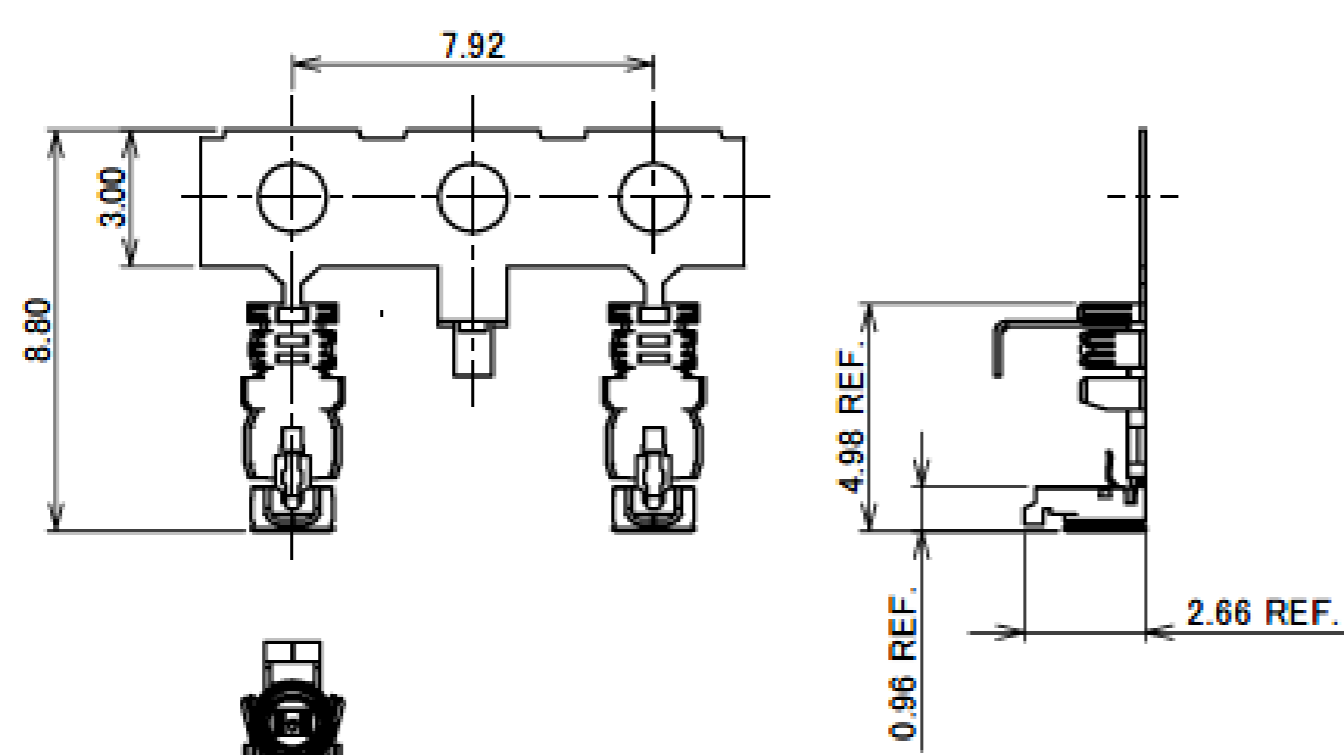
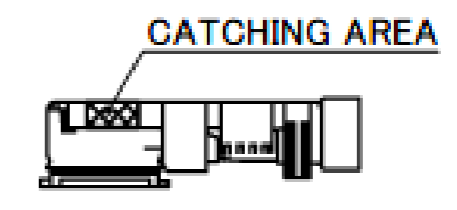

CARRIER CONDITION
S = 5:1

NO.	DESCRIPTION	MATERIAL	FINISH , REMARKS
3	GROUND CONTACT	PHOSPHOR BRONZE	ALL OVER Ni 1.00 μm MIN. CONTACT PART Au 0.05 μm MIN. [Ni PLATING AREA] Ni ONLY
2	CONTACT	PHOSPHOR BRONZE	ALL OVER Ni 1.00 μm MIN. CONTACT PART Au 0.10 μm MIN.
1	HOUSING	PBT	UL94V-0, BLACK

Rev.10

MHF® 4L plug Ni top (1.13,0.95)

Recommended P/N 20565-001R-83

PART NO.
20565-001R-83

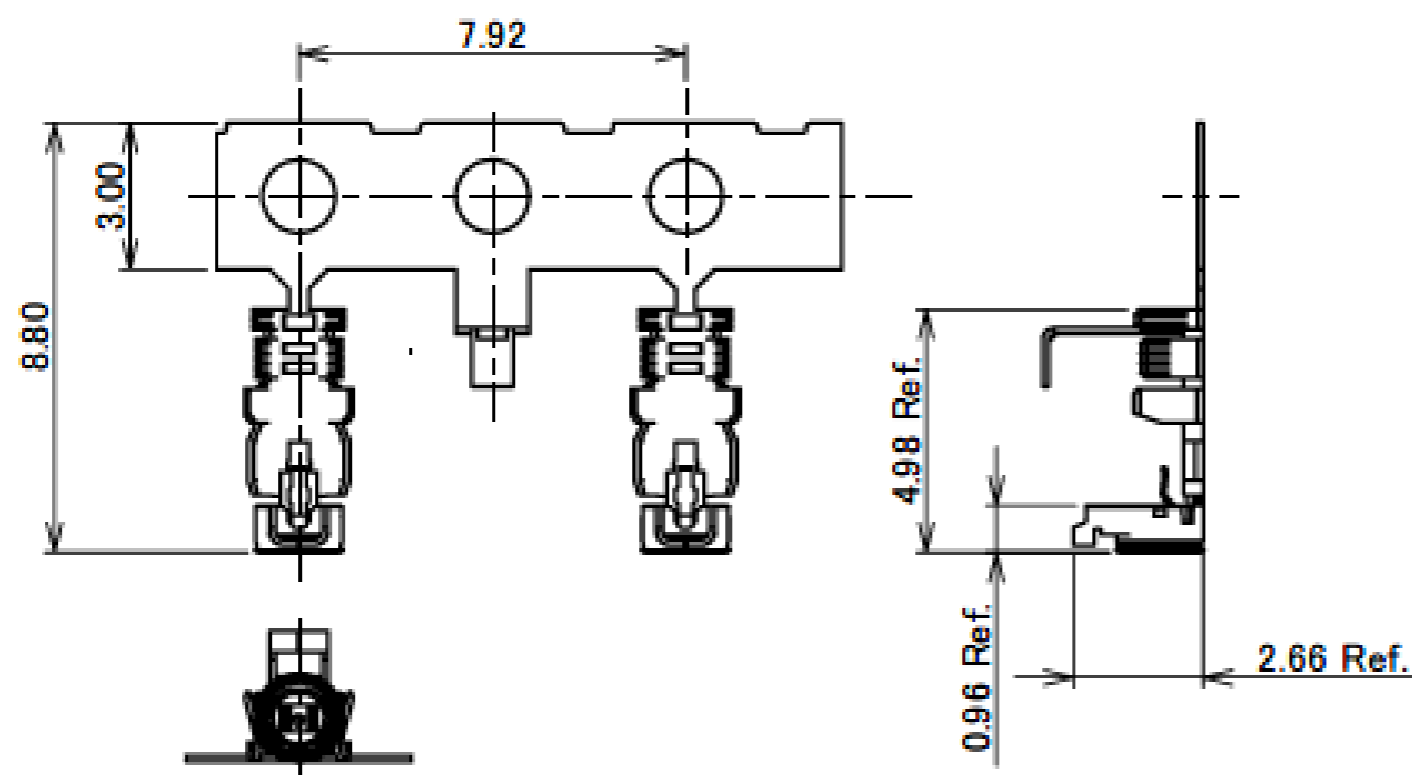
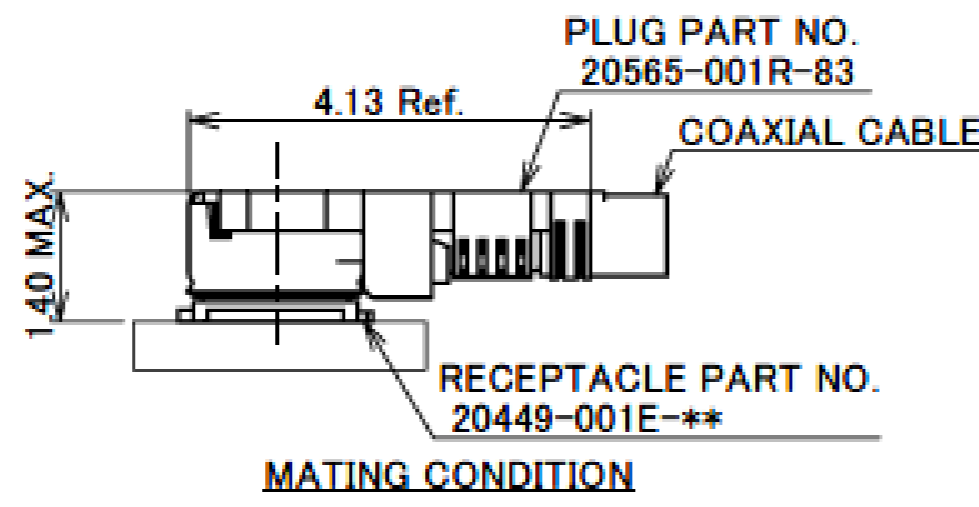
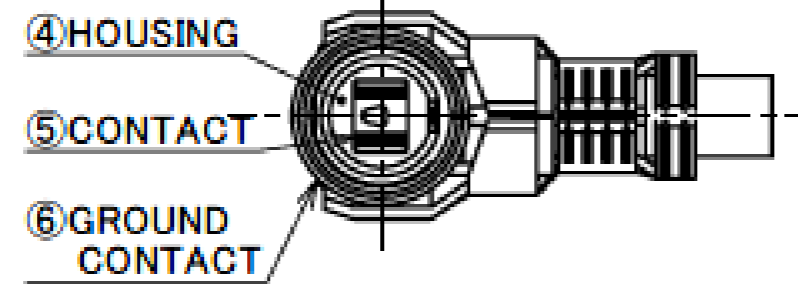
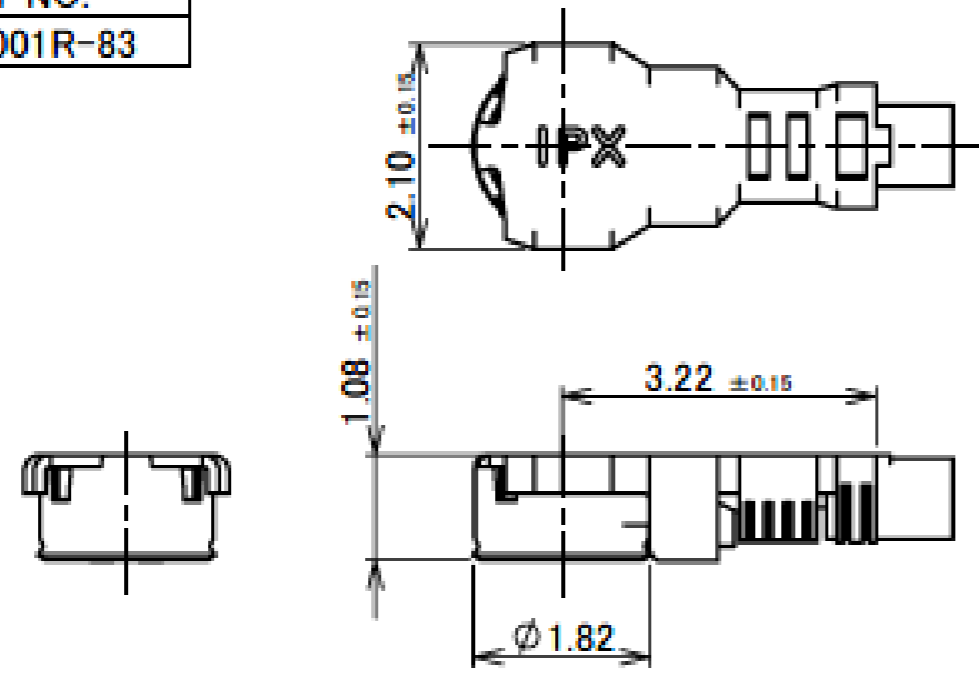

CARRIER CONDITION
S = 5:1

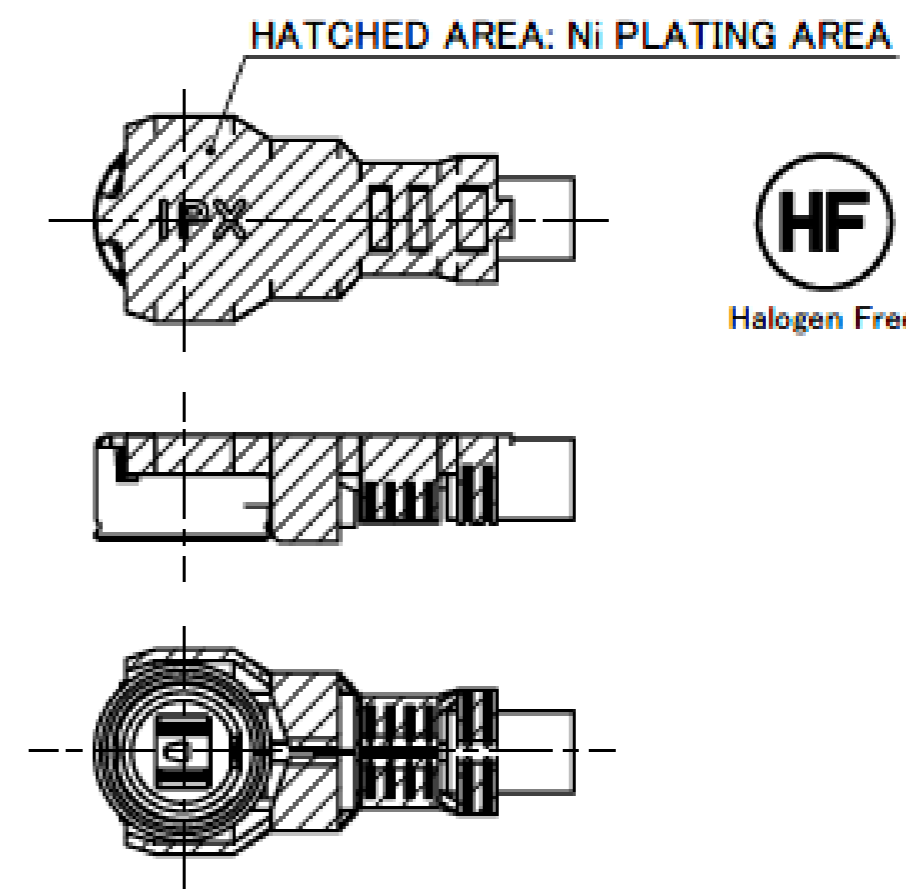
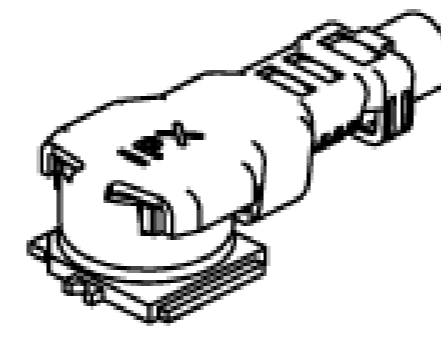

NOTES.

3. APPLICABLE CONNECTOR:
20449-001E-**
20579-001E-**

4. MATING AND UNMATING INSTRUCTION

4-1. MATING

MATE THE CONNECTOR VERTICALLY AS MUCH AS POSSIBLE, ADJUSTING THE MATING AXIS OF PLUG AND RECEPTACLE. DO NOT SLANT MATE.

4-2. UNMATING INSTRUCTION

4-2-1. IN CASE OF UNMATING BY PULLING TOOL (PART NO. 90609-0001) USE THE PULLING TOOL AS THE FOLLOWING DRAWING, AND PULL PLUG TO VERTICAL DIRECTION AS DIRECTLY AS POSSIBLE.

4-2-2. IN CASE OF UNMATING DIRECTLY BY HAND

CATCH THE CATCHING AREA OF PLUG, AND PULL PLUG TO VERTICAL DIRECTION AS DIRECTLY AS POSSIBLE.

NOTE 4-1.

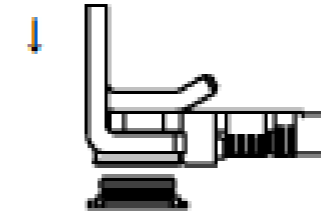

NOTE 4-2-1.

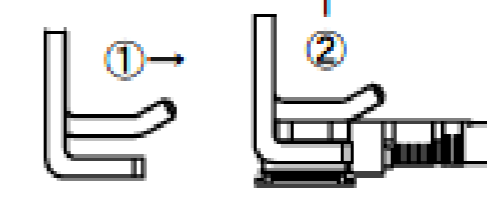

NOTE 4-2-2.

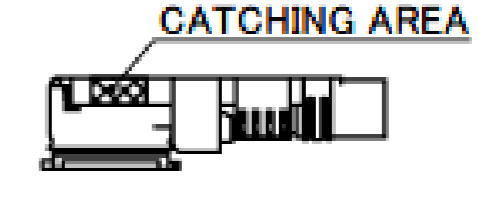

NO.	DISCRIPTION	MATERIAL	FINISH , REMARKS
6	GROUND CONTACT	PHOSPHOR BRONZE	ALL OVER Ni 1.00 μm MIN. CONTACT PART Au 0.05 μm MIN. [Ni PLATING AREA] Ni ONLY
5	CONTACT	PHOSPHOR BRONZE	CONTACT PART FINISH: Au 0.10 μm MIN. UNDER PLATE: Ni 1.00 μm MIN.
4	HOUSING	PBT	UL94V-0, BLACK

ITEMS	SPECIFICATION		
APPLICABLE CABLE	AWG#32 (1.13 O.D.)	AWG#33 (0.95 O.D.)	AWG#33 (0.83 O.D.)
RECOMMENDED APPLICABLE CONNECTOR PART No.	20449-001E-**		
RATING VOLTAGE	60 V AC (R.M.S)		
RATING FREQUENCY (MATED WITH MHF 4 RECEPTACLE PART No.20449-001E-**)	DC ~ 9GHz		
OPERATING TEMPERATURE	233 ~ 363 K (-40°C ~ +90°C)		
VSWR (MATED WITH SMA ADAPTER PART No. 90449-001)	1.30 MAX. AT 0.1~3GHz, 1.45 MAX. AT 3~6GHz, 1.60 MAX. AT 6~9GHz, 1.90 MAX. AT 9~12GHz		
MAIN CONTACT RESISTANCE	INITIAL: 20 mohm MAX. / AFTER TEST: ΔR 20 mohm MAX.		
GROUND CONTACT RESISTANCE	INITIAL: 20 mohm MAX. / AFTER TEST: ΔR 20 mohm MAX.		
INSULATION RESISTANCE	INITIAL: 500 Mohm MIN. / AFTER TEST: 100 Mohm MIN.		
DIELECTRIC WITHSTANDING VOLTAGE	200 V AC, 1 MINUTE		
DURABILITY	30 CYCLES		
MATING FORCE (INITIAL / AFTER TEST)	INITIAL: 30 N MAX. / AFTER TEST: 30 N MAX.		
UNMATING FORCE (INITIAL / AFTER TEST)	INITIAL: 20 N MAX. 5 N MIN. / AFTER TEST: 20 N MAX. 3 N MIN.		
PRODUCT SPECIFICATION	PRS-1772	PRS-2051	PRS-2062
TEST REPORT	TR-13011	TR-14142	TR-15011
PACKING STANDARD	PST-12066		
INSTRUCTION MANUAL	HIM-12012		
APPEARANCE CRITERIA No.	QLS-A***		

Rev.10

MHF® 4L plug Ni top (0.81,0.64)

Recommended P/N	20572-001R-08
PART NO.	
20572-001R-08	

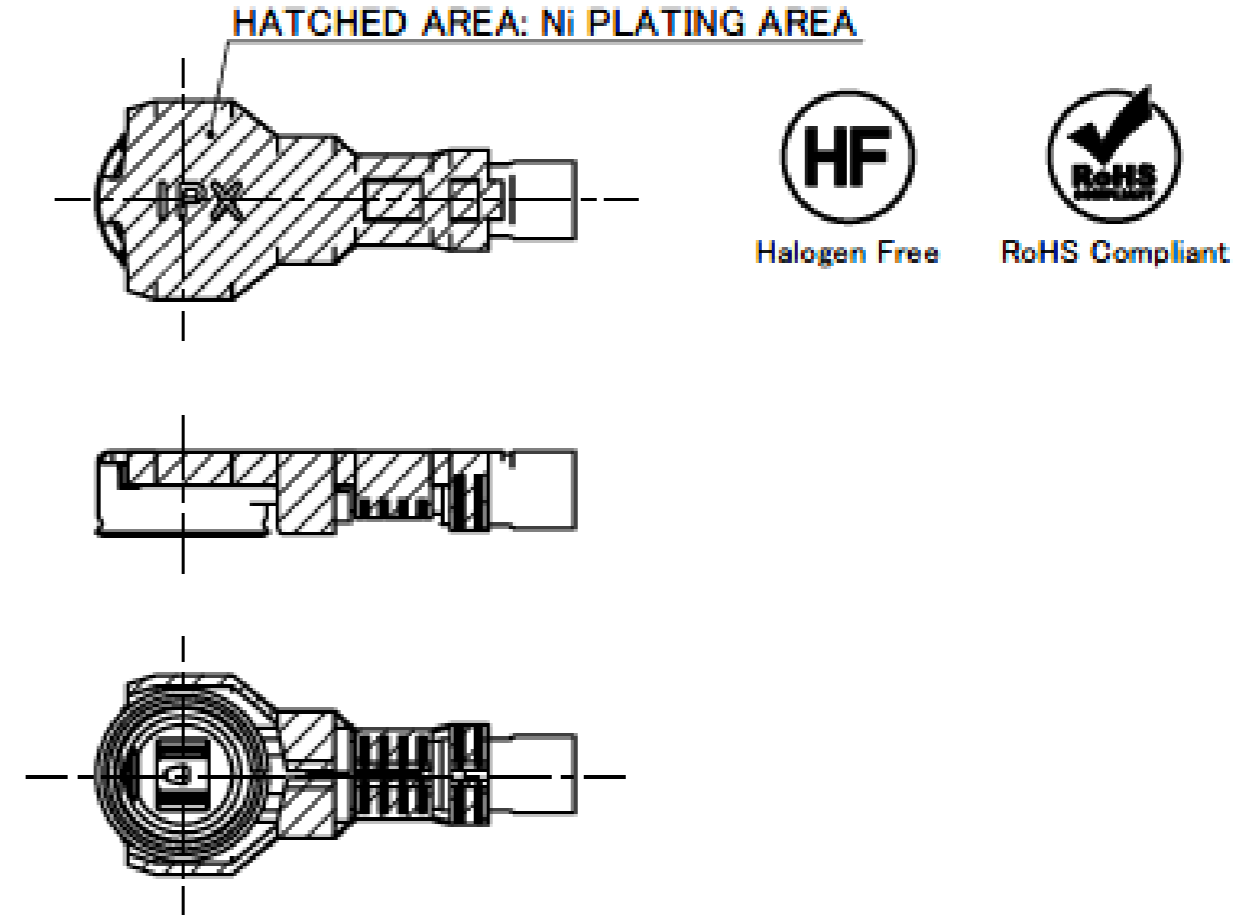
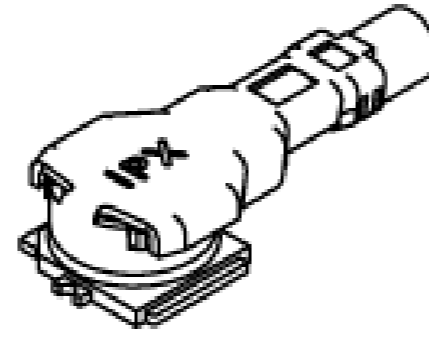
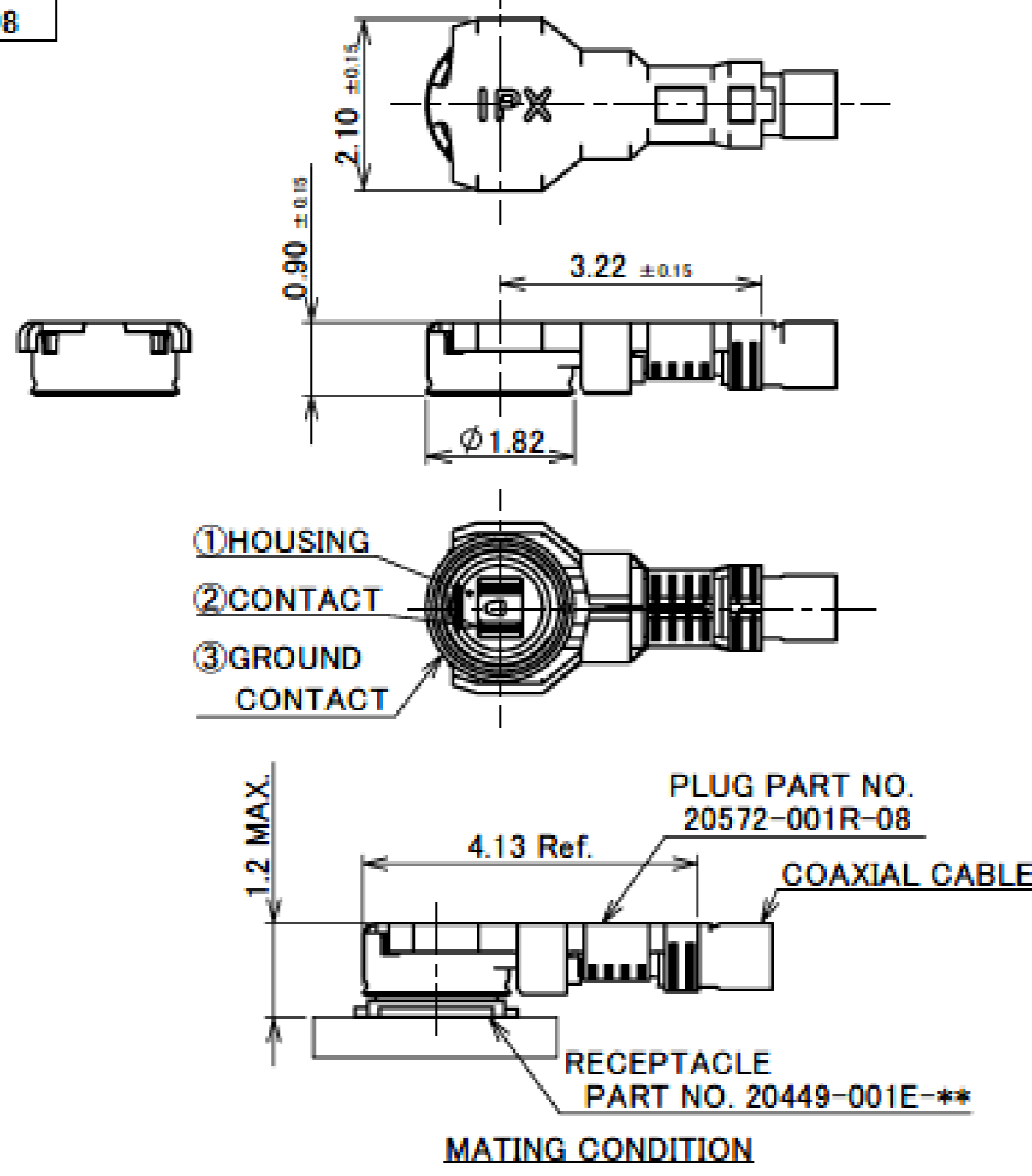

- NOTES.
- APPLICABLE CONNECTOR
20449-001E-**
20579-001E-**
 - MATING AND UNMATING INSTRUCTION
 - MATING
MATE THE CONNECTOR VERTICALLY AS MUCH AS POSSIBLE, ADJUSTING THE MATING AXIS OF PLUG AND RECEPTACLE. DO NOT SLANT MATE.
 - UNMATING INSTRUCTION
 - IN CASE OF UNMATING BY PULLING TOOL (PART NO. 90609-0001)
USE THE PULLING TOOL AS THE FOLLOWING DRAWING, AND PULL PLUG TO VERTICAL DIRECTION AS DIRECTLY AS POSSIBLE.
 - IN CASE OF UNMATING DIRECTLY BY HAND
CATCH THE CATCHING AREA OF PLUG, AND PULL PLUG TO VERTICAL DIRECTION AS DIRECTLY AS POSSIBLE.

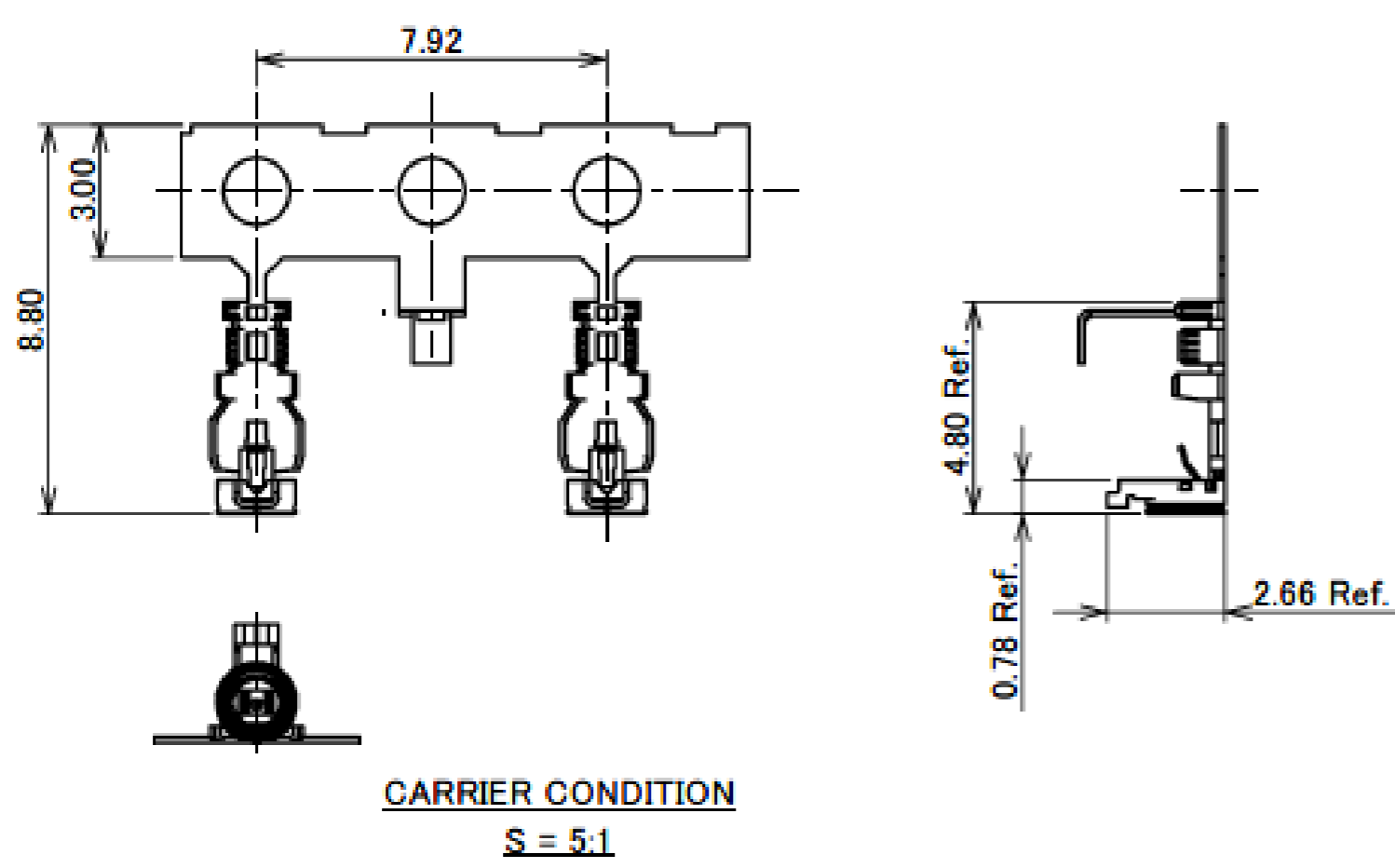
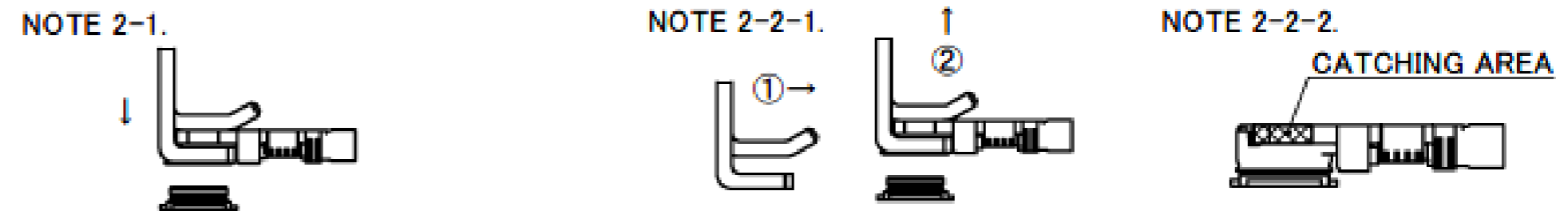

NO.	DESCRIPTION	MATERIAL	FINISH , REMARKS
3	GROUND CONTACT	PHOSPHOR BRONZE	ALL OVER Ni 1.00 μm MIN. CONTACT PART Au 0.05 μm MIN. [Ni PLATING AREA] Ni ONLY
2	CONTACT	PHOSPHOR BRONZE	ALL OVER Ni 1.00 μm MIN. CONTACT PART Au 0.10 μm MIN.
1	HOUSING	PBT	UL94V-0, BLACK

ITEMS	SPECIFICATION	
APPLICABLE CABLE	AWG#36 (0.81 O.D.)	AWG#36 (0.64 O.D.)
RECOMMENDED CONNECTOR PART No.	20449-001E-**	
RATING VOLTAGE	60 V AC (R.M.S)	
RATING FREQUENCY (MATED WITH MHF 4 RECEPTACLE PART No.20449-001E-**)	DC~9 GHz	
OPERATING TEMPERATURE	233~363K (-40°C~+90°C)	
VSWR (MATED WITH SMA ADAPTER PART No. 90449-001)	1.30 MAX. AT 0.1~3 GHz, 1.45 MAX. AT 3~6 GHz, 1.60 MAX. AT 6~9 GHz, 1.90 MAX. AT 9~12 GHz	
MAIN CONTACT RESISTANCE	INITIAL: 20 mohm MAX. / AFTER TEST: ΔR 20 mohm MAX.	
GROUND CONTACT RESISTANCE	INITIAL: 20 mohm MAX. / AFTER TEST: ΔR 20 mohm MAX.	
INSULATION RESISTANCE	INITIAL: 500 Mohm MIN. / AFTER TEST: 100 Mohm MIN.	
DIELECTRIC WITHSTANDING VOLTAGE	200 V AC, 1 MINUTE	
DURABILITY	30 CYCLES	
MATING FORCE (INITIAL / AFTER TEST)	INITIAL: 30 N MAX. / AFTER TEST: 30 N MAX.	
UNMATING FORCE (INITIAL / AFTER TEST)	INITIAL: 20 N MAX. 5 N MIN. / AFTER TEST: 20 N MAX. 3 N MIN.	
CRIMP STRENGTH	-	
PRODUCT SPECIFICATION	PRS-1772	PRS-1944
TEST REPORT	TR-13011	TR-14078
PACKING STANDARD	PST-12066	
INSTRUCTION MANUAL	HIM-12011	
APPEARANCE CRITERIA No.	QLS-A***	

Rev.8

MHF® 4L plug Ni top (0.81,0.64)

PART NO.	20572-001R-08	
APPLICABLE CABLE STRIP DIMENSION	<p>※DO NOT USE SOLDER COATED EITHER INNER OR OUTER CONDUCTOR CABLES.</p>	<p>※DO NOT USE SOLDER COATED EITHER INNER OR OUTER CONDUCTOR CABLES.</p>
NOTES	<p>3.REQUIREMENTS CHARACTERISTIC IMPEDANCE: 50(±3)ohm BY TDR METHOD NOMINAL CAPACITANCE (REFERENCE VALUE): 96pF/m CONDUCTOR RESISTANCE OF INNER CONDUCTOR AT 293 (REFERENCE): OD 0.81 TYPE/OD 0.64 TYPE...1400ohm/km INSULATION RESISTANCE: OD 0.81 TYPE/OD 0.64 TYPE... 1000Mega-ohm.km MIN. DIELECTRIC WITH STANCE VOLTAGE: OD 0.81 TYPE...NO BREAKDOWN AT AC 1500V FOR 1 MINUTES. OD 0.64 TYPE...NO BREAKDOWN AT AC 500V FOR 1 MINUTES.</p>	
BRAIDED SHIELD OF OUTER CONDUCTOR	SINGLE BRAIDED SHIELD	SINGLE SPIRAL SHIELD
PART NO. OF SEMI AUTO TERMINATION MACHINE	90599-008	90599-006
CRIMP HEIGHT	<p>CH-1 (i-Fit® PART) 0.83~0.87 CH-2 (SHIELD PART) 0.76~0.80 CH-3 (JACKET PART) 0.92~0.96</p>	<p>CH-1 (i-Fit® PART) 0.81~0.85 CH-2 (SHIELD PART) 0.73~0.77 CH-3 (JACKET PART) 0.71~0.75</p>
	※USE FOR POINT MICROMETER.	※USE FOR POINT MICROMETER.

Rev.8

Accessories for MHF® 4L (0.81,0.64,1.13,0.95)

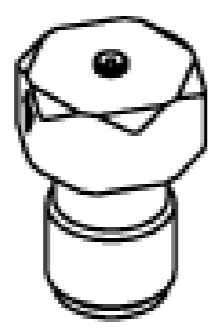

MHF 4 (4L) SMA ADAPTOR
PART NO. 90449-001

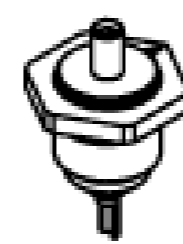

MHF 4 (4L) INSPECTION CONNECTOR
PART NO. 90449-003-01

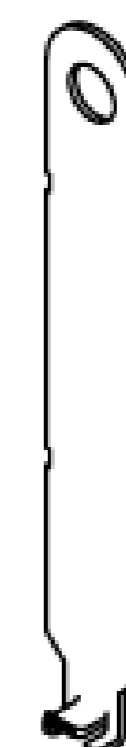
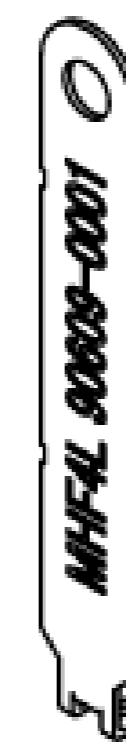

FRONT SIDE

BACK SIDE

MHF 4L PUSHING AND PULLING TOOL
PART NO. 90609-0001

Rev.8

MHF[®] 4L Receptacle

Recommended P/N		20579-001E
PART NO.	PACKING QUANTITY / REEL	
20579-001E	10,000 PCS.	
20579-001E-01	20,000 PCS.	

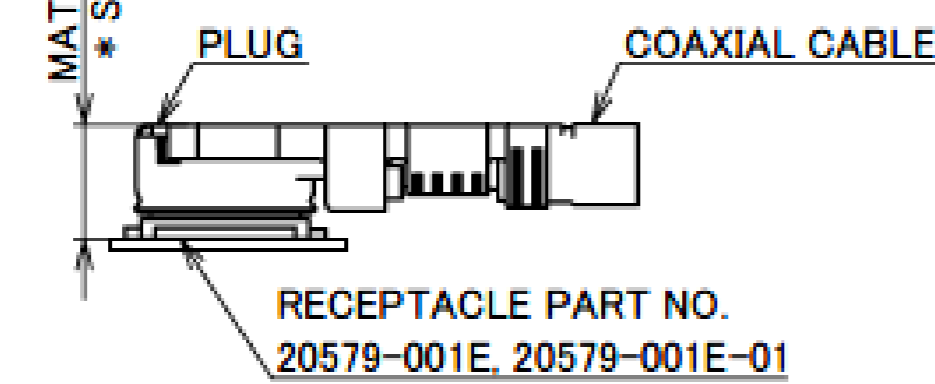
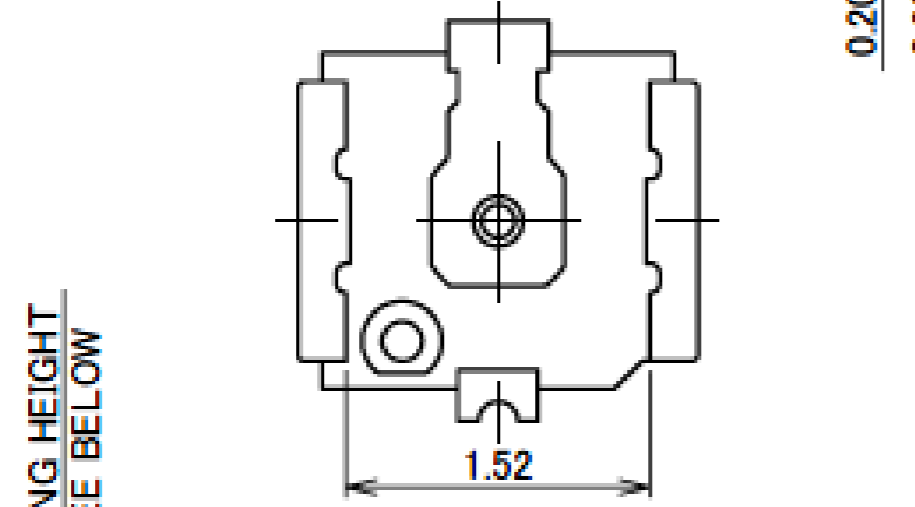
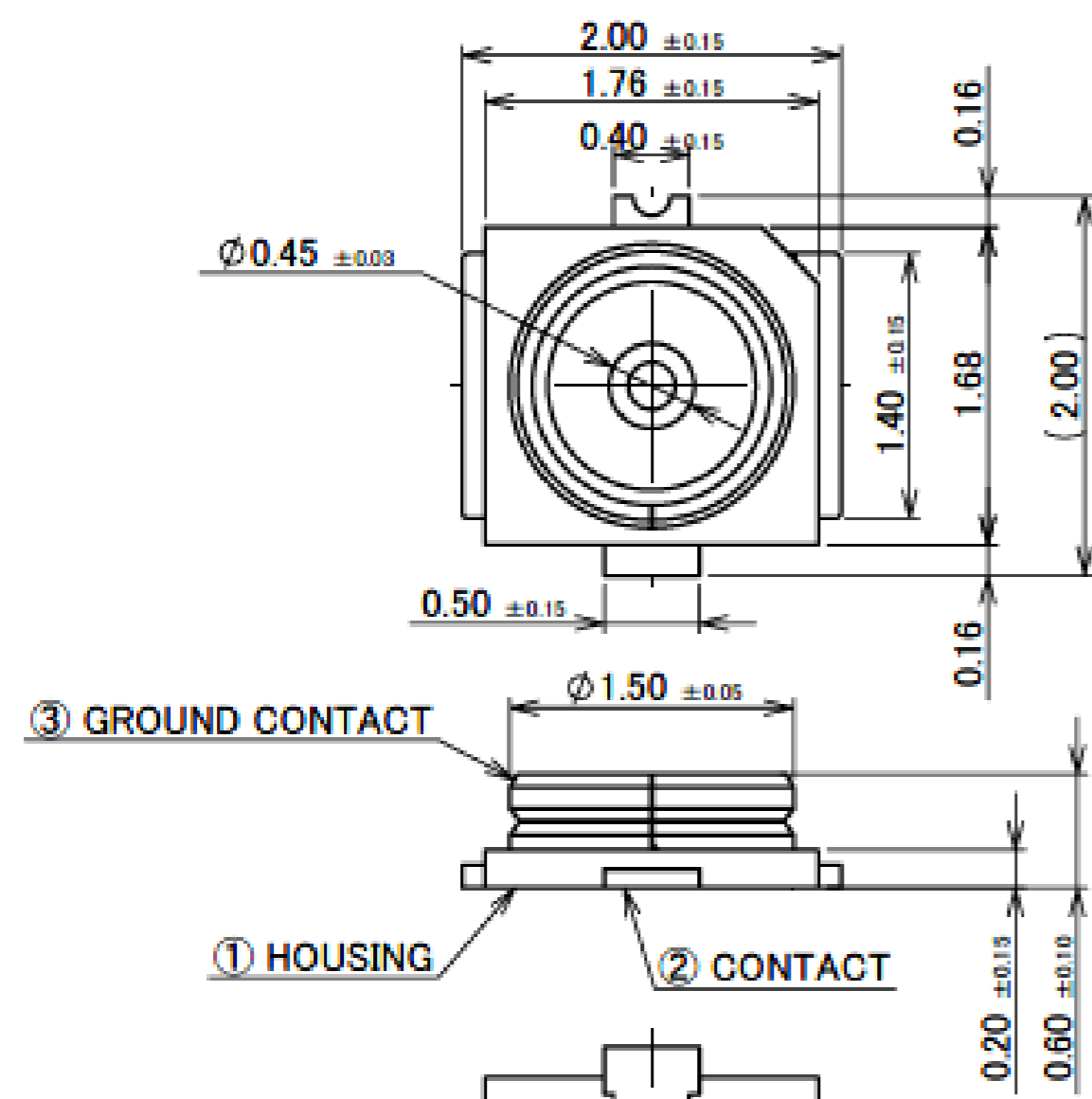
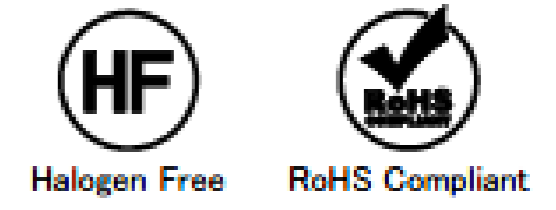

* MATING HEIGHT
 1.2 MAX. WITH 20611-001R, 20572-001R-08, 20448-00*R-081, 20448-001R-081E
 1.4 MAX. WITH 20565-001R-**
 1.7 MAX. WITH 20632-001R-37
 (2.0 MAX. WITH MHF 4L LK LOCKED CONDITION)

MATING CONDITION
 WITH MHF 4/MHF 4L PLUG
 (S = 10/1)

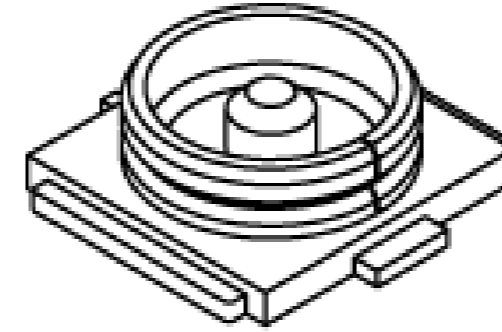
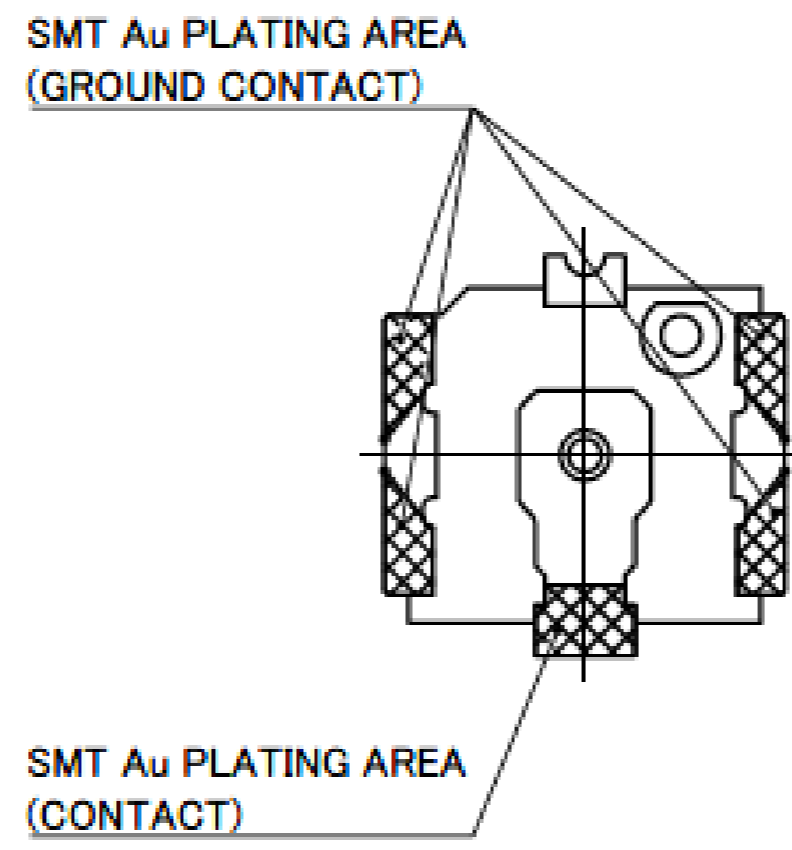

NOTES.
 1. APPLICABLE CONNECTOR (CABLE SIZE)
 MHF 4 PLUG: 20611-001R (Φ0.81)
 20448-00*R-081 (Φ0.81)
 20448-001R-081E (Φ0.81)
 MHF 4L PLUG: 20572-001R-08 (Φ0.64, Φ0.81)
 20565-001R-** (Φ0.83, Φ0.95, Φ1.13)
 20632-001R-37 (Φ1.37)
 2. COPLANARITY: 0.1 mm MAX.

NO.	DESCRIPTION	MATERIAL	FINISH, REMARKS
3	GROUND CONTACT	PHOSPHOR BRONZE	ALL OVER Ni 1.00 μm MIN. CONTACT PART: Au 0.05 μm MIN. , SOLDERING PART Au AREA: 0.03 μm MIN.
2	CONTACT	BRASS	ALL OVER Ni 1.00 μm MIN. CONTACT PART: Au 0.05 μm MIN. SOLDERING PART Au AREA: 0.03 μm MIN.
1	HOUSING	LCP	UL94V-0, BLACK

Rev.16

FOR MHF 4L PLUG

ITEMS	SPECIFICATION		
	20572-001R-08 (CABLE Φ0.81 TYPE)	20565-001R-13 (CABLE Φ1.13 TYPE)	20632-001R-37 (CABLE Φ1.37 TYPE)
APPLICABLE CONNECTOR PART No.			
RATING VOLTAGE	60 V AC (R.M.S)/DC		
RATING FREQUENCY	DC ~ 12GHz		
OPERATING TEMPERATURE	233~363 K(-40°C~+90°C)		
VSWR (MATED WITH SMA ADAPTER PART No. 90449-002)	1.30 MAX. AT 0.1~3GHz, 1.40 MAX. AT 3~6GHz, 1.50 MAX. 6~9GHz. 1.65 MAX. AT 9~12GHz		
MAIN CONTACT RESISTANCE	INITIAL : 20 mohm MAX. / AFTER TEST : ΔR 20 mohm MAX.		
GROUND CONTACT RESISTANCE	INITIAL : 20 mohm MAX. / AFTER TEST : ΔR 20 mohm MAX.		
INSULATION RESISTANCE	INITIAL : 500 Mohm MIN. / AFTER TEST : 100 Mohm MIN.		
DIELECTRIC WITHSTANDING VOLTAGE	200 V AC 1 MINUTE		
DURABILITY	30 CYCLES		
MATING FORCE (INITIAL / AFTER TEST)	INITIAL : 30 N MAX. / AFTER TEST : 30 N MAX.		
UNMATING FORCE (INITIAL / AFTER TEST)	INITIAL : 20 N MAX. 5 N MIN. / AFTER TEST : 20 N MAX. 3 N MIN.		
PRODUCT SPECIFICATION	PRS-1907		PRS-2925
TEST REPORT	TR-14097		TR-24070
PACKING STANDARD	20579-001E: PST-14004 20579-001E-01: PST-14067		
INSTRUCTION MANUAL	HIM-12011	HIM-12012	HIM-16011
APPEARANCE CRITERIA No.	QLS-A***		

Rev.16

MHF® 4L Receptacle

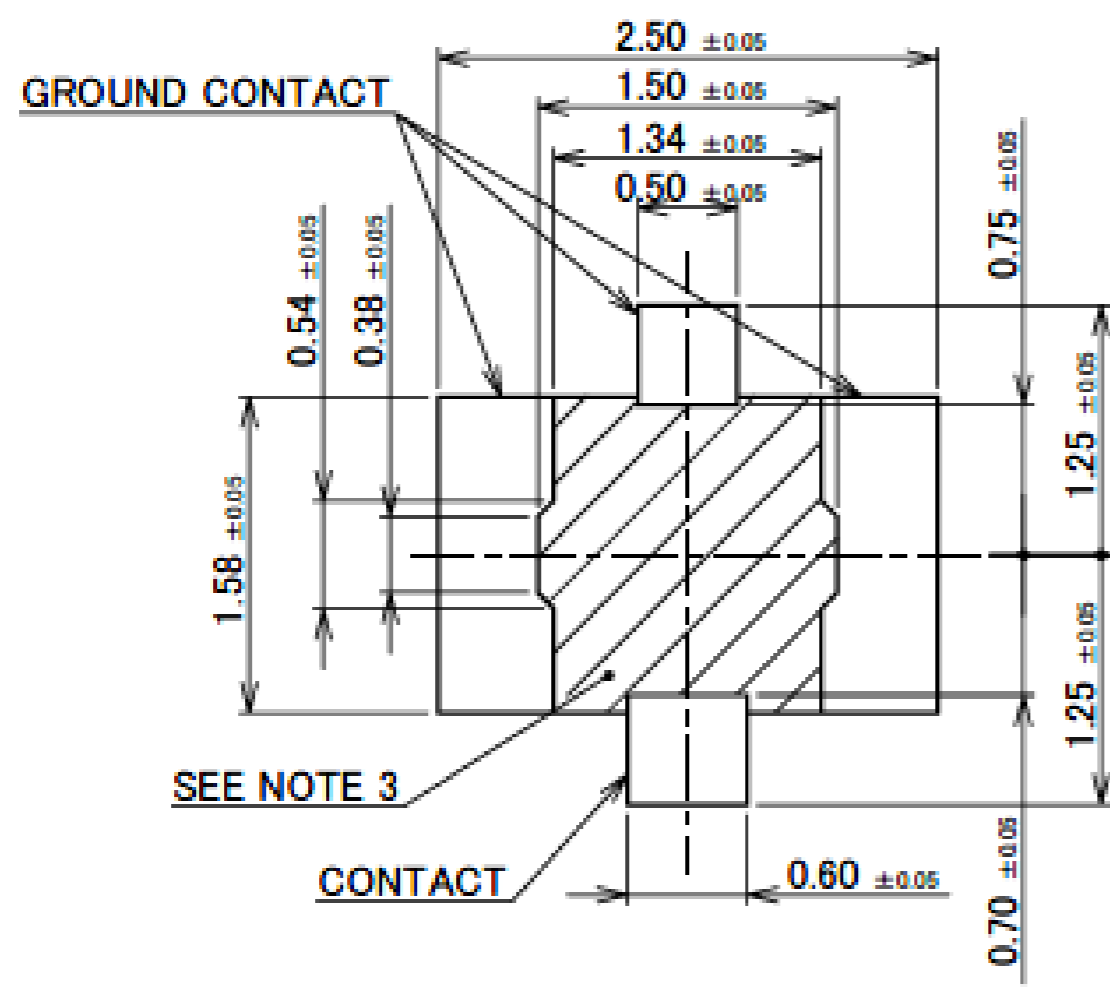

RECOMMENDED FOOTPRINT PATTERN

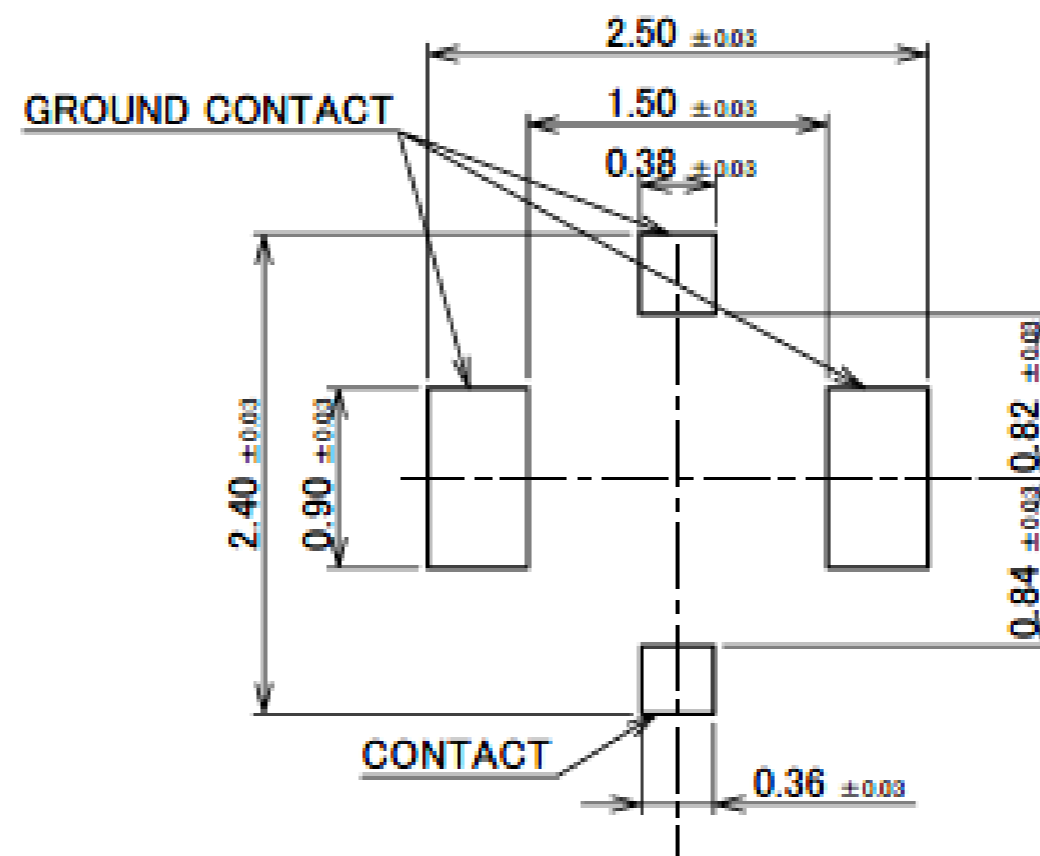

MASK THICKNESS: 0.12 mm

RECOMMENDED METAL MASK LAYOUT

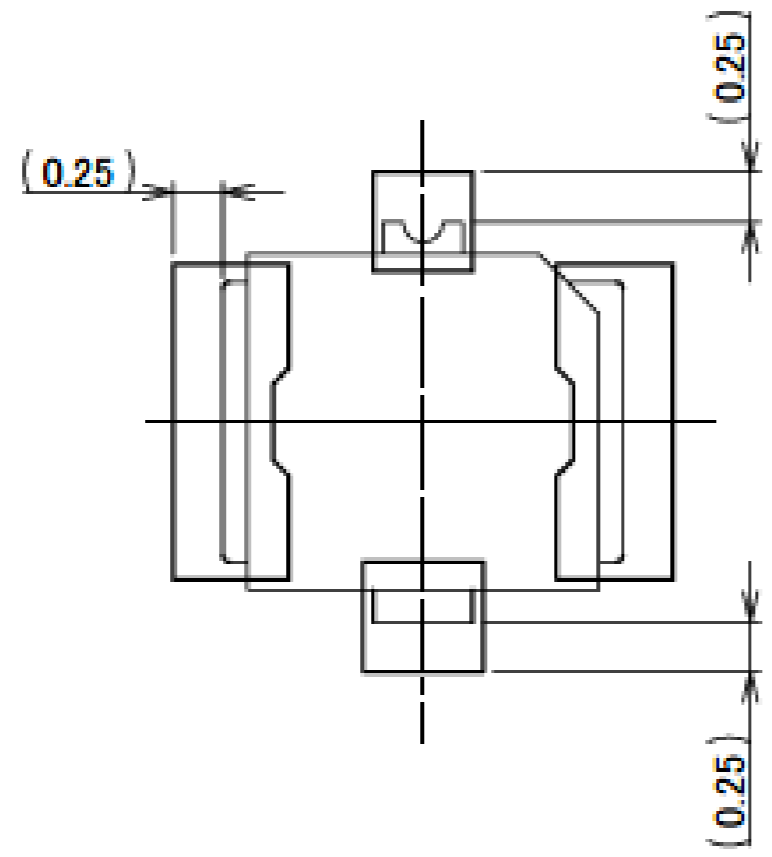

CONNECTOR ON RECOMMENDED FOOTPRINT PATTERN

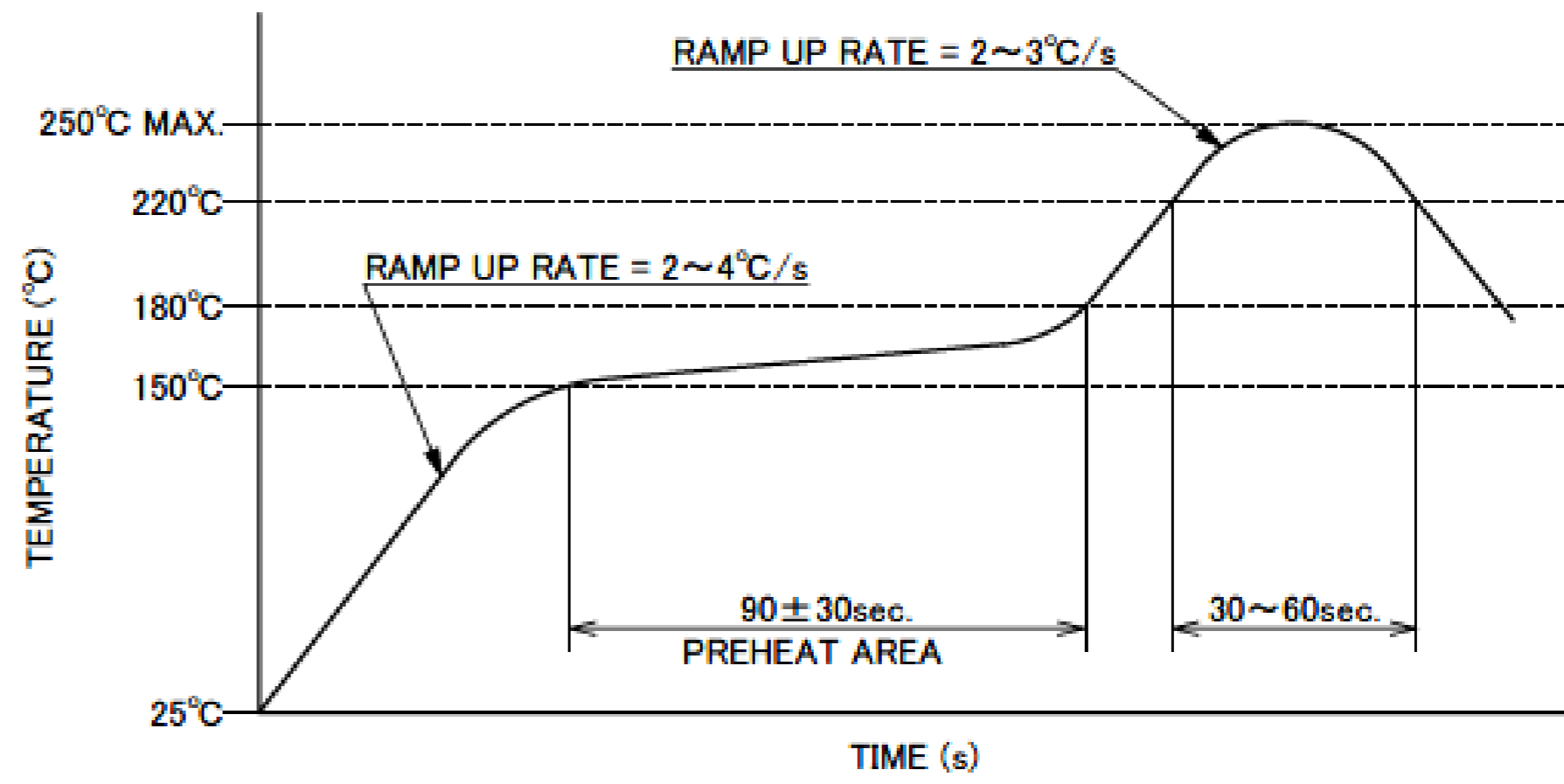

REFLOW TEMPERATURE PROFILE
SENJU METAL INDUSTRY CO., LTD. - M705-SHF(Sn96.5 Ag3.0 Cu0.5)

NOTE 3. NO GROUND, SIGNAL, AND RESIST IN THIS AREA.

Rev.16

COMPONENT PLACEMENT PROHIBITED AREA FOR MHF 4L RECEPTACLE MATED WITH MHF 4L LK HARNESS REQUIRED AREA FOR RECOMMENDED JIG TO OPERATE

SINGLE CONNECTOR LAYOUT

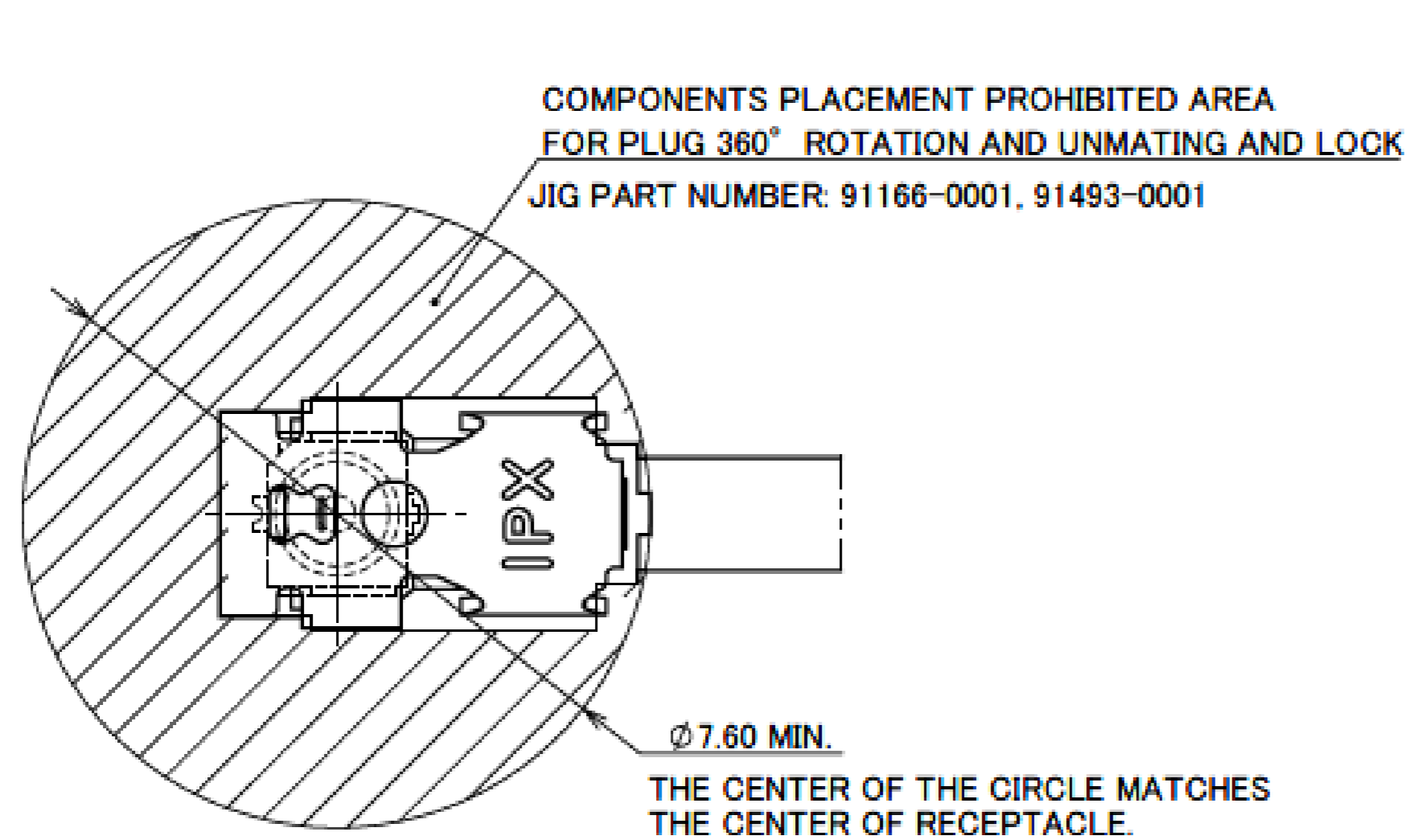

MATING AND LOCK CONDITION WITH MHF 4L LK HARNESS

MULTIPLE CONNECTORS LAYOUT

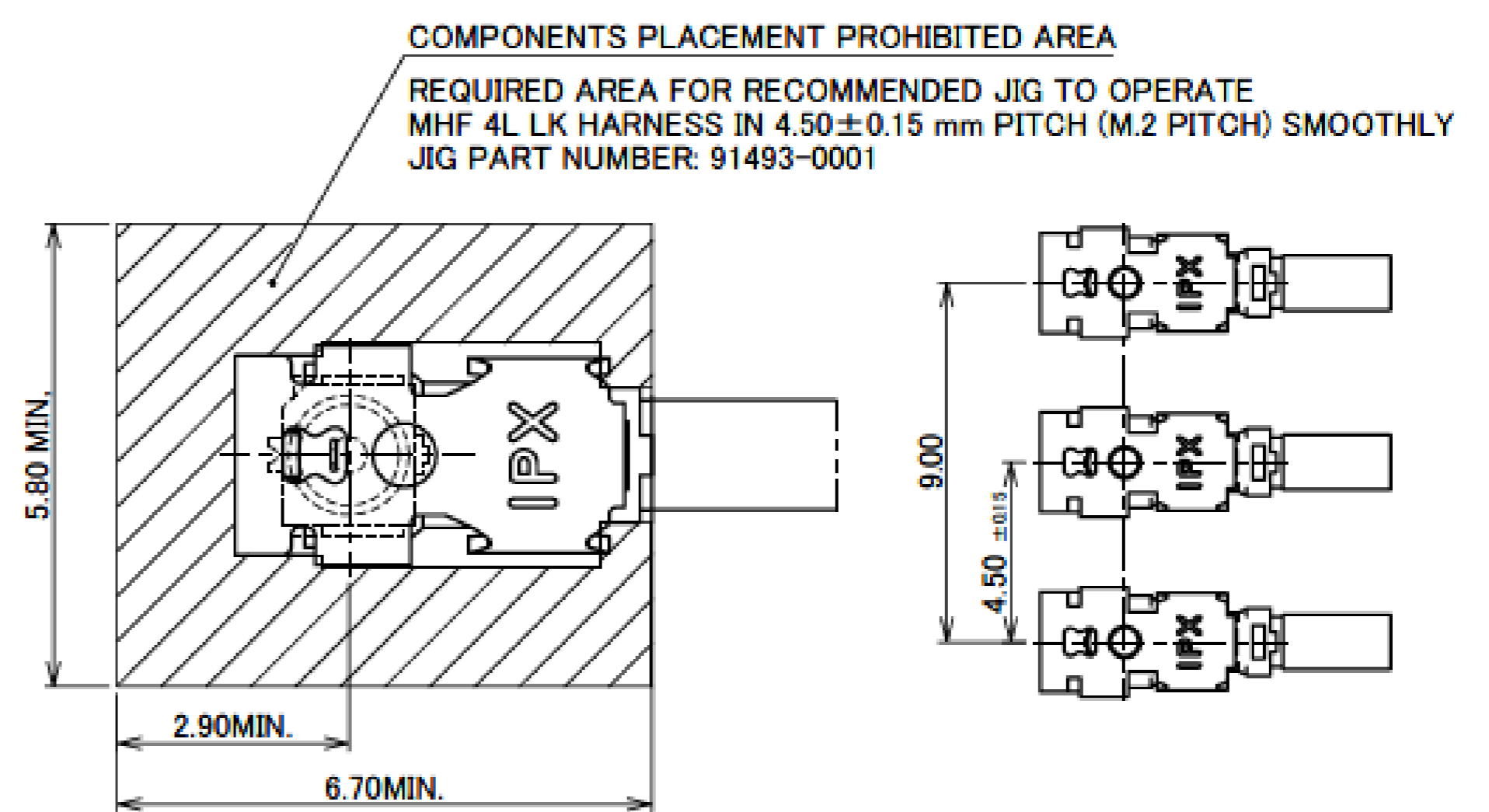

MATING AND LOCK CONDITION WITH MHF 4L LK HARNESS NARROW PITCH

MHF 4L LK HARNESS UNLOCK CONDITION NARROW PITCH DIMENSIONS (S = 5 : 1)

Rev.16

MHF® 4 Receptacle

FOR MHF 4L PLUG

ITEMS	SPECIFICATION			
	20572-001R-08 (CABLE Φ0.64 TYPE) (CABLE Φ0.81 TYPE)	20565-001E-13 (CABLE Φ0.95 TYPE) (CABLE Φ1.13 TYPE)	20565-001R-83 (CABLE Φ0.83 TYPE)	20632-001R-37 (CABLE Φ1.37 TYPE)
APPLICABLE CONNECTOR PART No.				
RATING VOLTAGE	60 V AC (R.M.S)/DC			
RATING FREQUENCY	DC ~ 9GHz			
OPERATING TEMPERATURE	233~363 K(-40°C~+90°C)			
CHARACTERISTIC IMPEDANCE	50 ohm (NOMINAL VALUE)			
VSWR (MATED WITH SMA ADAPTER PART No. 90449-002)	1.30 MAX. AT 0.1~3GHz, 1.40 MAX. AT 3~6GHz, 1.55 MAX. AT 6~9GHz			
MAIN CONTACT RESISTANCE	INITIAL : 20 mohm MAX. / AFTER TEST : Δ R 20 mohm MAX.			
GROUND CONTACT RESISTANCE	INITIAL : 20 mohm MAX. / AFTER TEST : Δ R 20 mohm MAX.			
INSULATION RESISTANCE	INITIAL : 500 Mohm MIN. / AFTER TEST : 100 Mohm MIN.			
DIELECTRIC WITHSTANDING VOLTAGE	200 V AC 1 MINUTE			
DURABILITY	30 CYCLES			
MATING FORCE (INITIAL / AFTER TEST)	INITIAL : 30 N MAX. / AFTER TEST : 30 N MAX.			
UNMATING FORCE (INITIAL / AFTER TEST)	INITIAL : 20 N MAX. 5 N MIN. / AFTER TEST : 20 N MAX. 3 N MIN.			
PRODUCT SPECIFICATION	PRS-1944 (CABLE Φ0.64 TYPE) PRS-1772 (CABLE Φ0.81 TYPE)	PRS-2051 (CABLE Φ0.95 TYPE) PRS-1772 (CABLE Φ1.13 TYPE)	PRS-2062 (CABLE Φ0.83 TYPE)	PRS-2008 (CABLE Φ1.37 TYPE)
TEST REPORT	TR-14078 (CABLE Φ0.64 TYPE) TR-13011 (CABLE Φ0.81 TYPE)	TR-14142 (CABLE Φ0.95 TYPE) TR-13011 (CABLE Φ1.13 TYPE)	TR-15011 (CABLE Φ0.83 TYPE)	TR-14100 (CABLE Φ1.37 TYPE)
PACKING STANDARD	20449-001E-03: 300-604			
INSTRUCTION MANUAL	HIM-12011	HIM-12012		HIM-16011
APPEARANCE CRITERIA No.	QLS-A***			

Rev.21

FOR MHF 4 SMT PLUG

ITEMS	SPECIFICATION
	20462-001E (MHF 4 SMT PLUG)
APPLICABLE CONNECTOR PART No.	
RATING VOLTAGE	60 V AC (R.M.S)/DC
RATING FREQUENCY	DC~9GHz
OPERATING TEMPERATURE	233~363 K(-40°C~+90°C)
CHARACTERISTIC IMPEDANCE	50 ohm (NOMINAL VALUE)
VSWR (MATED WITH SMA ADAPTER PART No. 90449-002)	1.30 MAX. AT 0.1~3GHz, 1.40 MAX. AT 3~6GHz, 1.55 MAX. AT 6~9GHz
MAIN CONTACT RESISTANCE	INITIAL : 20 mohm MAX. / AFTER TEST : Δ R 20 mohm MAX.
GROUND CONTACT RESISTANCE	INITIAL : 20 mohm MAX. / AFTER TEST : Δ R 20 mohm MAX.
INSULATION RESISTANCE	INITIAL : 500 Mohm MIN. / AFTER TEST : 100 Mohm MIN.
DIELECTRIC WITHSTANDING VOLTAGE	200 V AC 1 MINUTE
DURABILITY	30 CYCLES
MATING FORCE (INITIAL / AFTER TEST)	INITIAL : 30 N MAX. / AFTER TEST : 15 N MAX.
UNMATING FORCE (INITIAL / AFTER TEST)	INITIAL : 4 N MIN. / AFTER TEST : 2 N MIN.
PRODUCT SPECIFICATION	PRS-1404
TEST REPORT	TR-08022
PACKING STANDARD	20449-001E-03: 300-604
INSTRUCTION MANUAL	HIM-15005
APPEARANCE CRITERIA No.	QLS-A***

Rev.21

MHF[®] 4 Receptacle

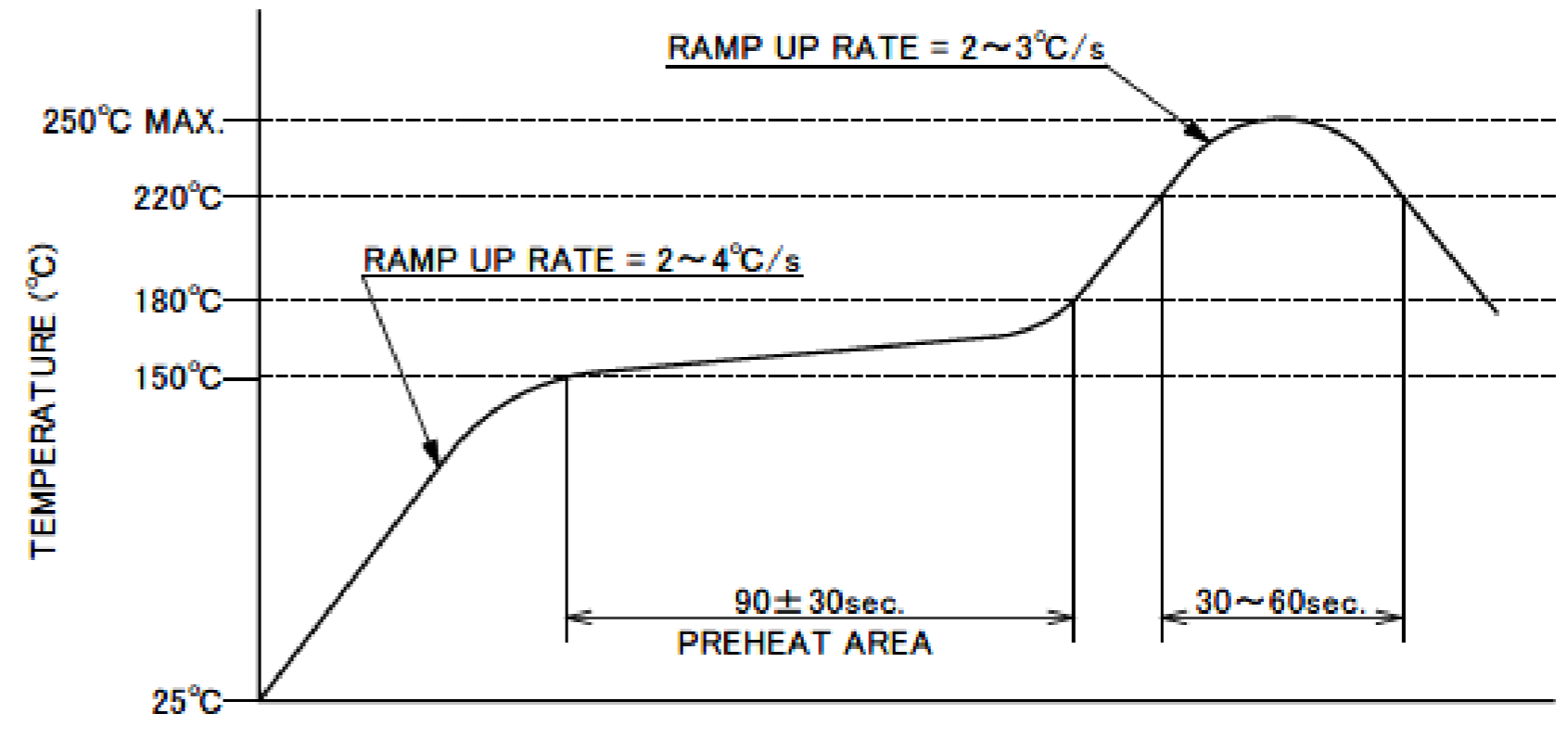
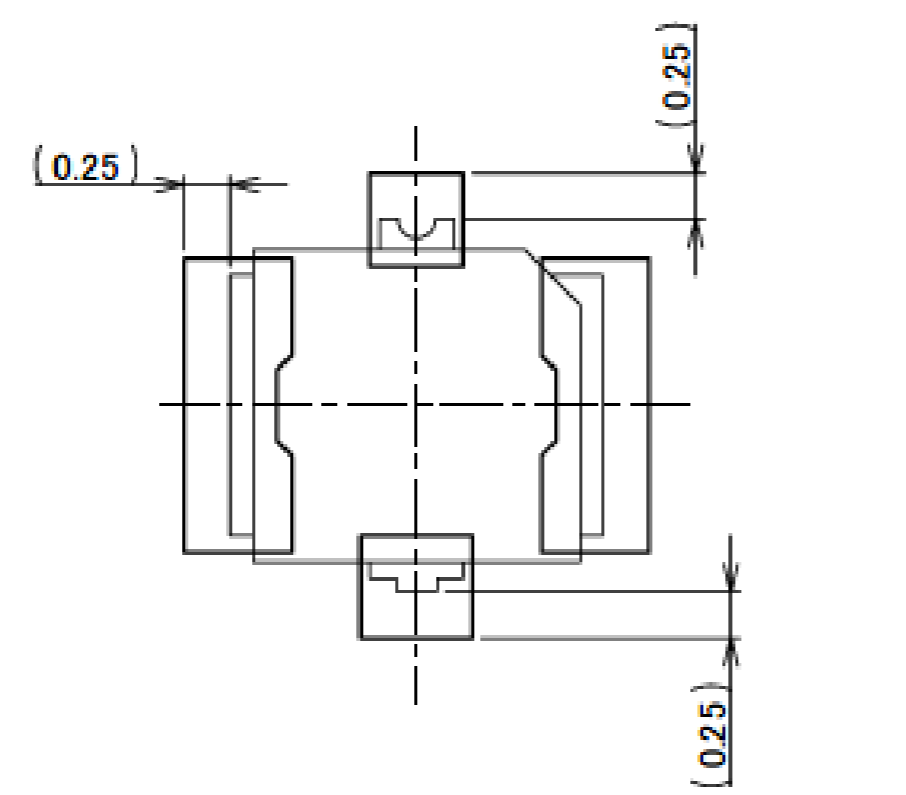
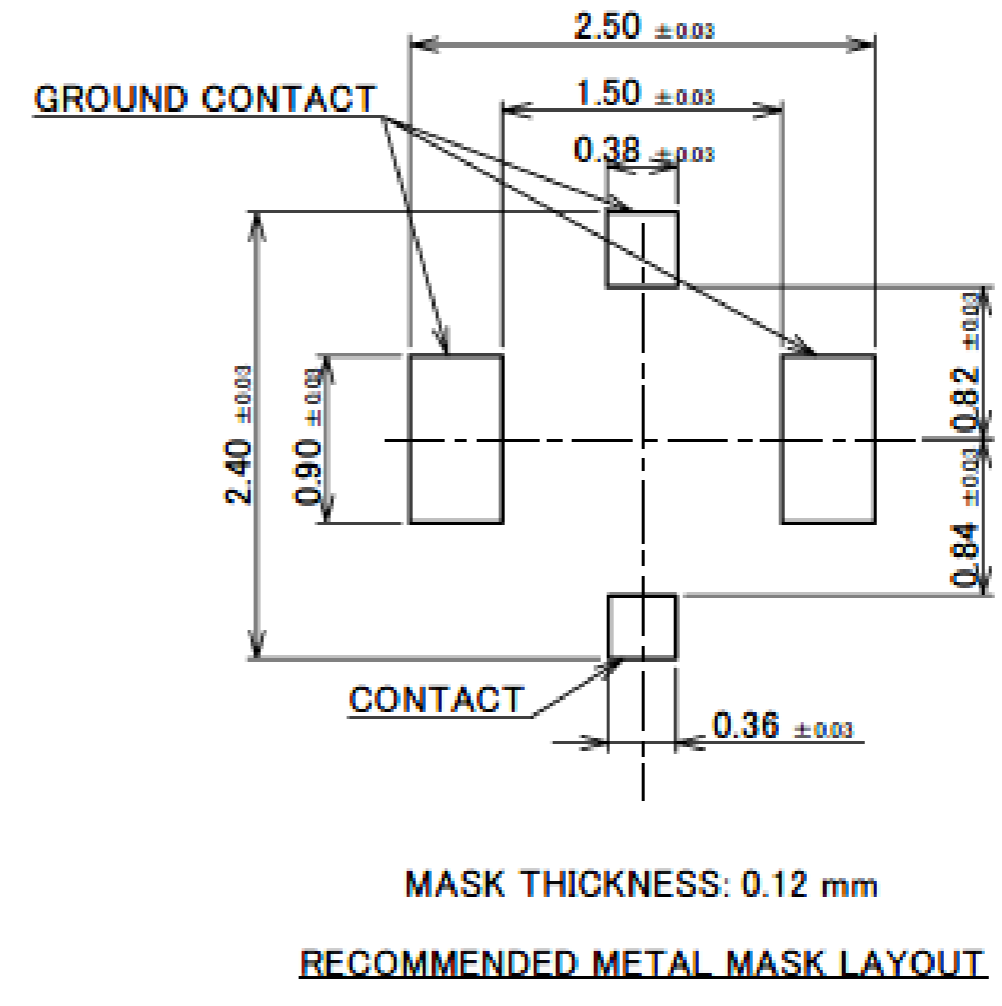
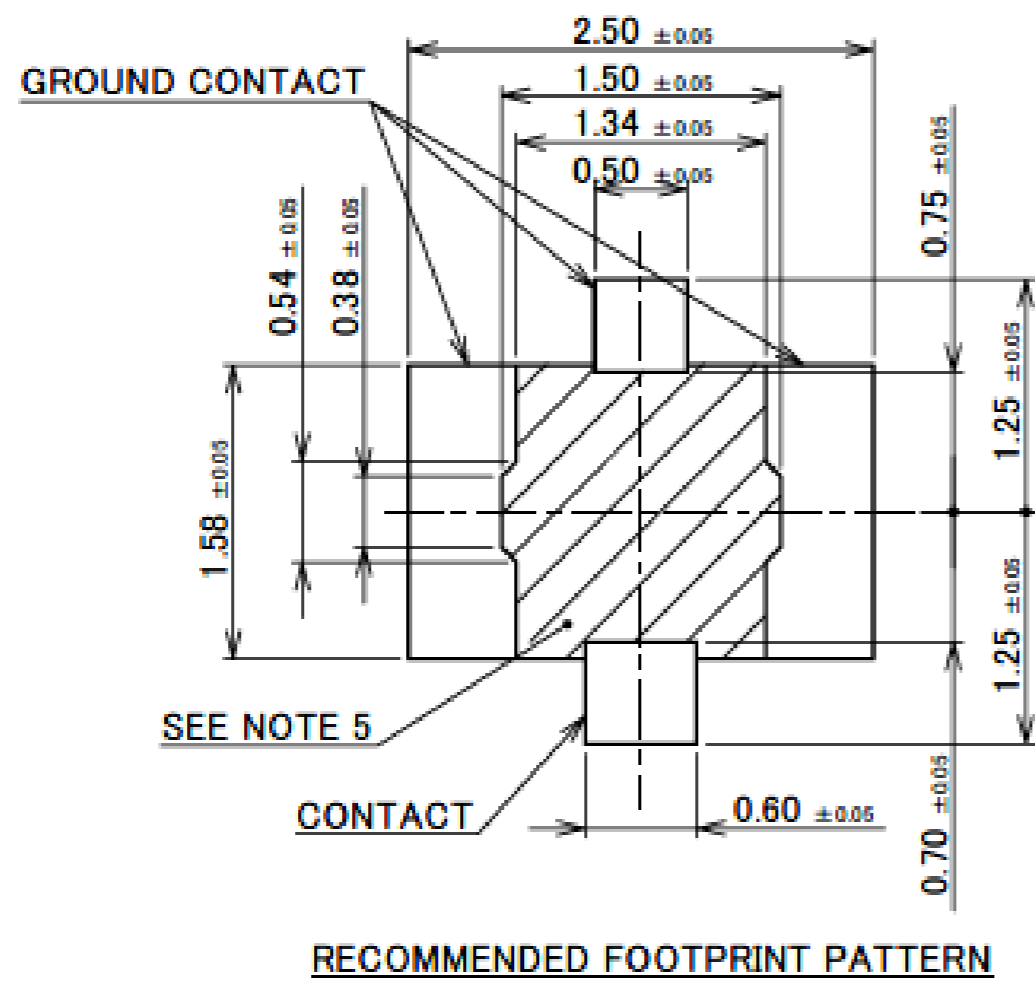

NOTE 5. NO GROUND, SIGNAL, AND RESIST IN THIS AREA.

Rev.21

COMPONENT PLACEMENT PROHIBITED AREA FOR MHF 4 RECEPTACLE MATED WITH MHF 4L LK HARNESS REQUIRED AREA FOR RECOMMENDED JIG TO OPERATE

SINGLE CONNECTOR LAYOUT

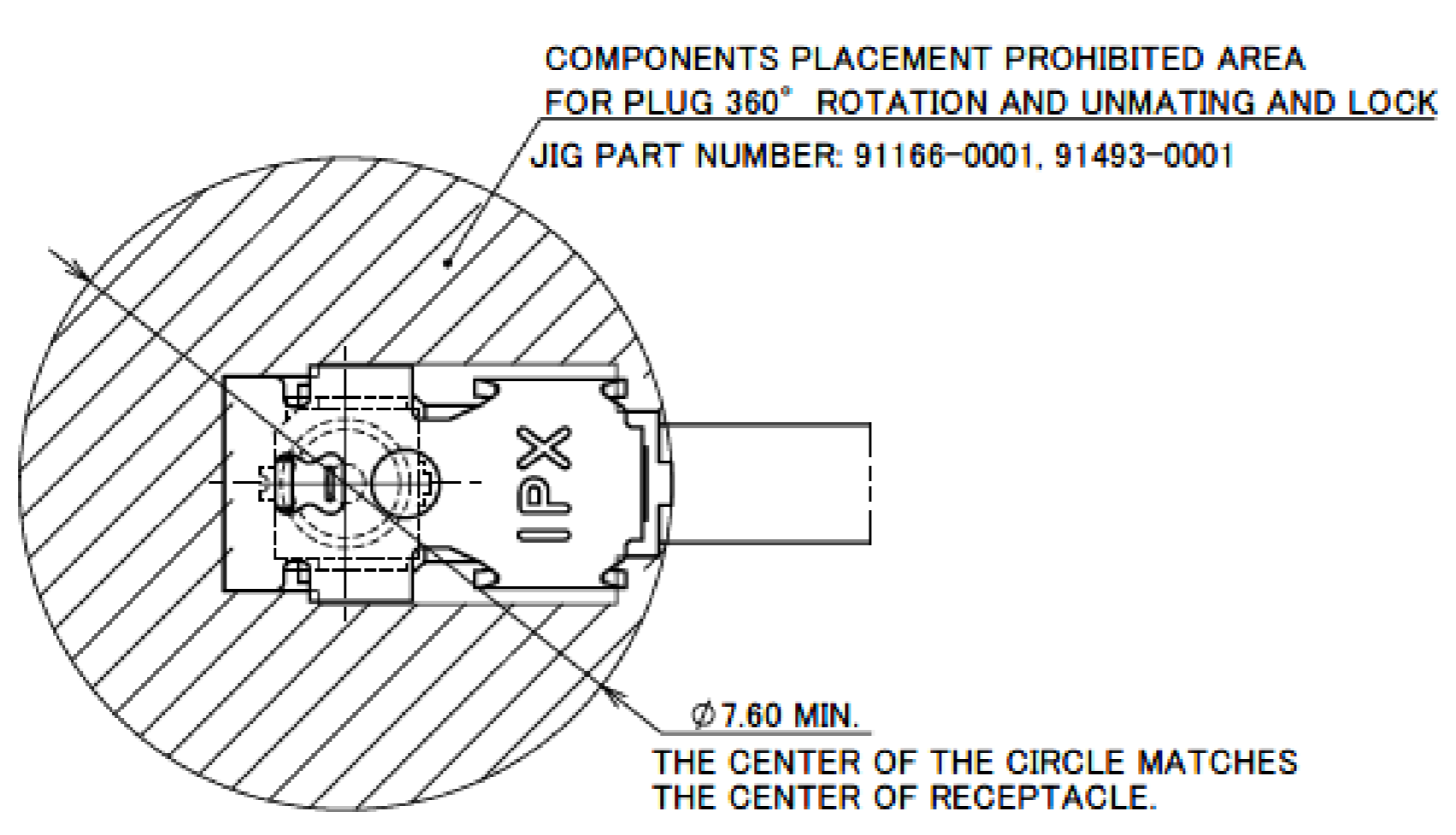

MATING AND LOCK CONDITION WITH MHF 4L LK HARNESS

MULTIPLE CONNECTORS LAYOUT

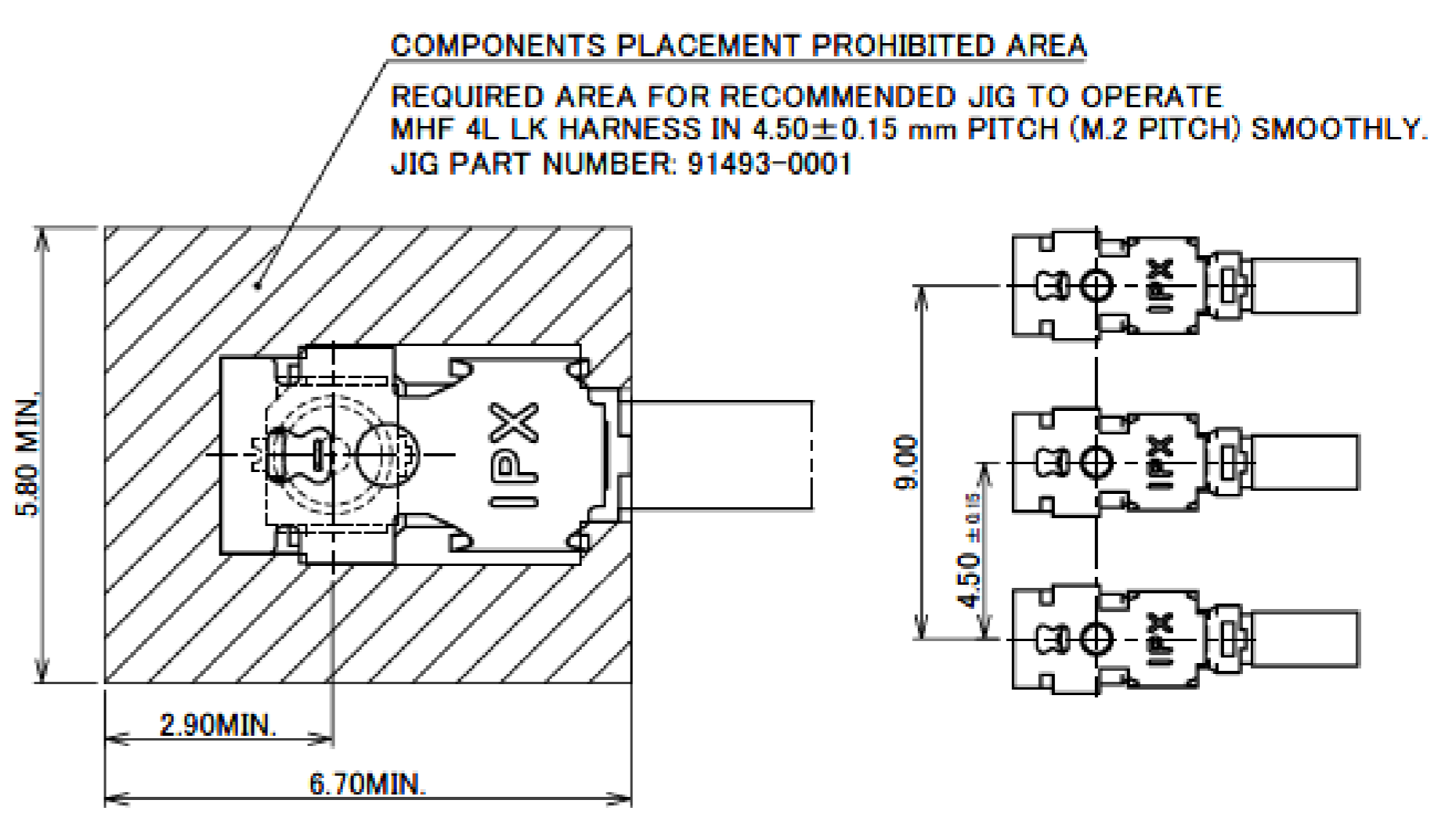

MATING AND LOCK CONDITION WITH MHF 4L LK HARNESS NARROW PITCH

MHF 4L LK HARNESS UNLOCK CONDITION NARROW PITCH DIMENSIONS (S = 5 : 1)

Accessories for MHF® 4L Receptacle

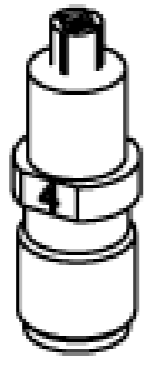

MHF 4 (4L) SMA ADAPTER
PART NO. 90449-002



MHF 4 RECEPTACLE HIGH CYCLE ATTACHMENT
PART NO. 90683-0001

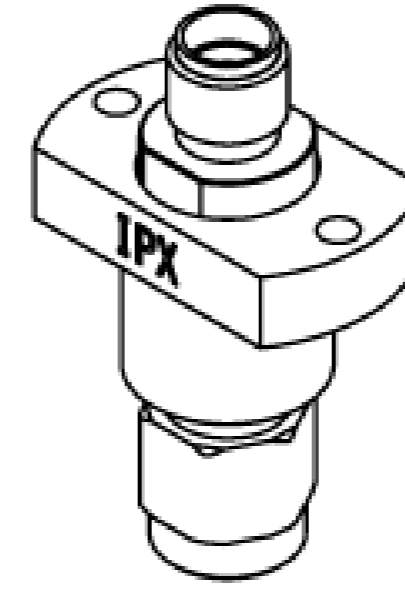

MHF SERIES HIGH CYCLE SMA ADAPTER BASE UNIT
PART NO. 90684-0001

* 90683-0001 AND 90684-0001 SHOULD BE USED TOGETHER.

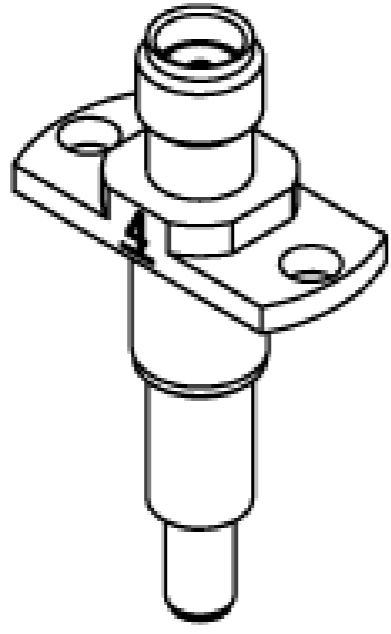

MHF4(4L) RECEPTACLE HIGH CYCLE SMA ADAPTER
PART NO. 90698-0001

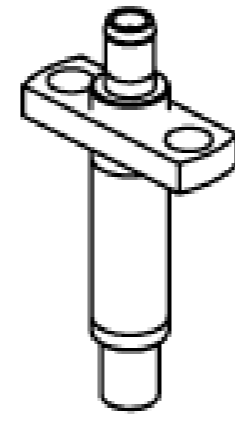

MHF4(4L) RECEPTACLE HIGH CYCLE N45 C ADAPTER
PART NO. 90576-0001

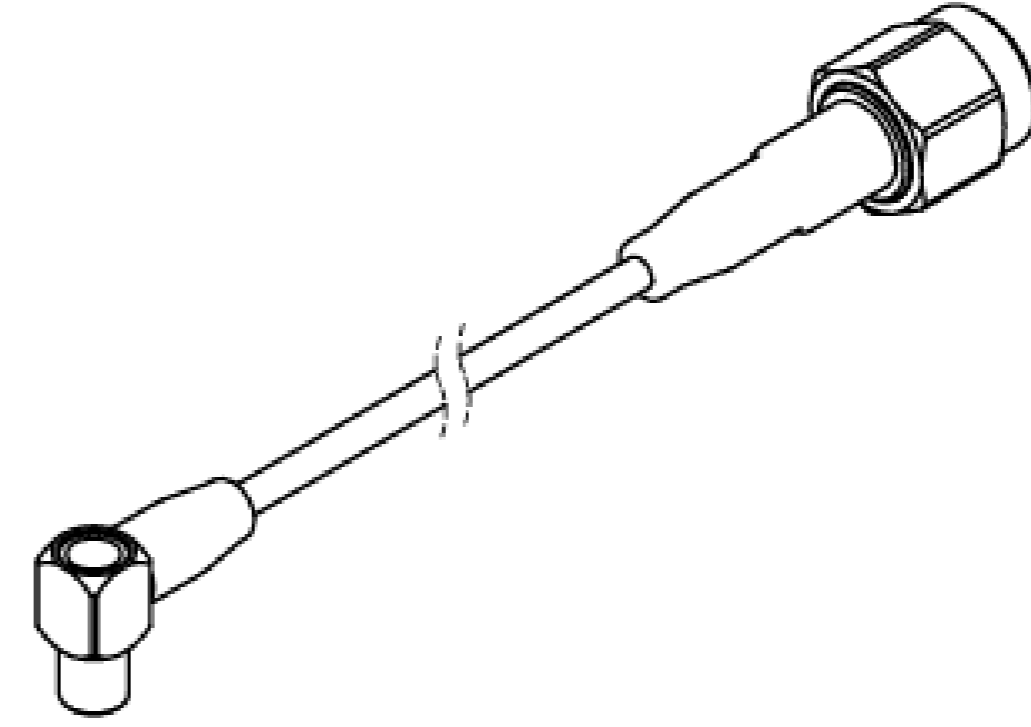

MHF SERIES N45 C TO SMA ADAPTER CABLE
PART NO. 90577-****

* 90576-0001 AND 90577-**** SHOULD BE USED TOGETHER.

Custom Connectors Available

 RF Connectors

MHF® series



CABLIN® series



Micro-coaxial/Twinax Connectors



Wire-to-Board Connectors/Terminals

AP series



ISH® series

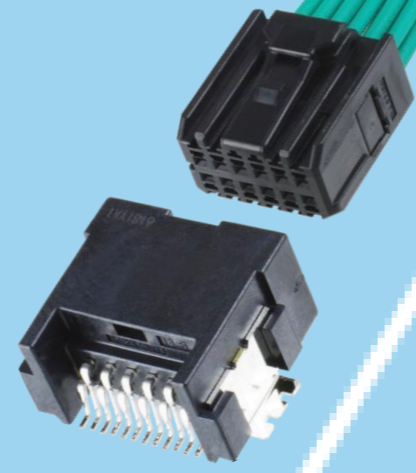

NOVASTACK® series



Board-to-Board Connectors



I/O Connectors

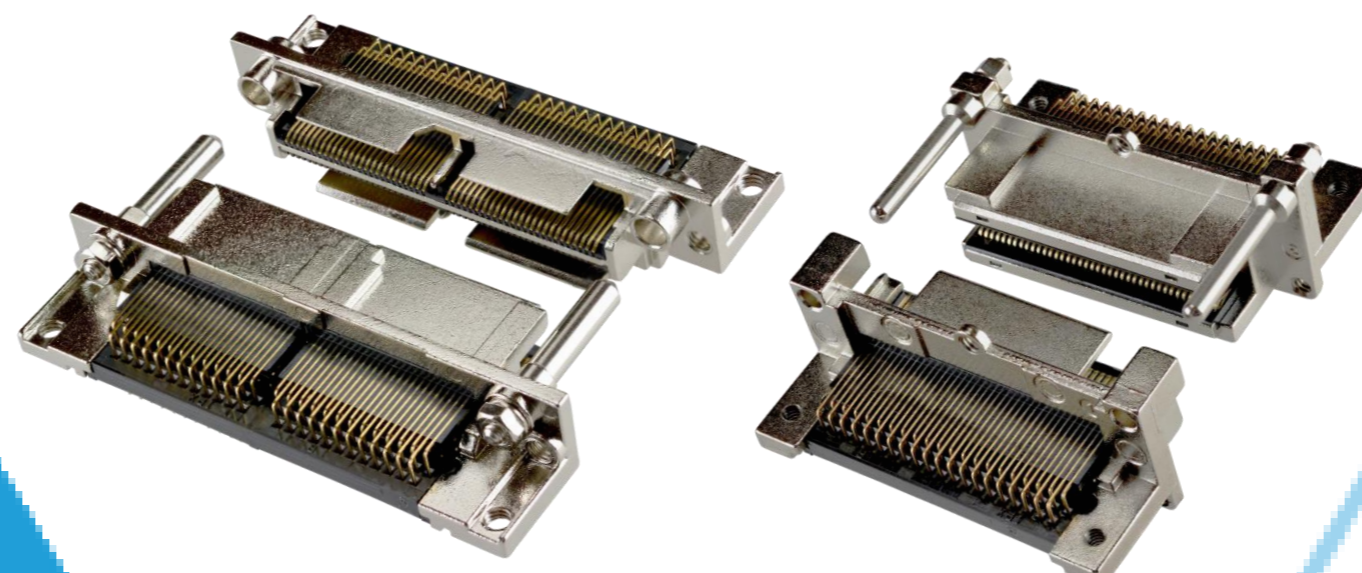

MINIDOCK™ series

MINIFLEX® series

EVAFLEX® series

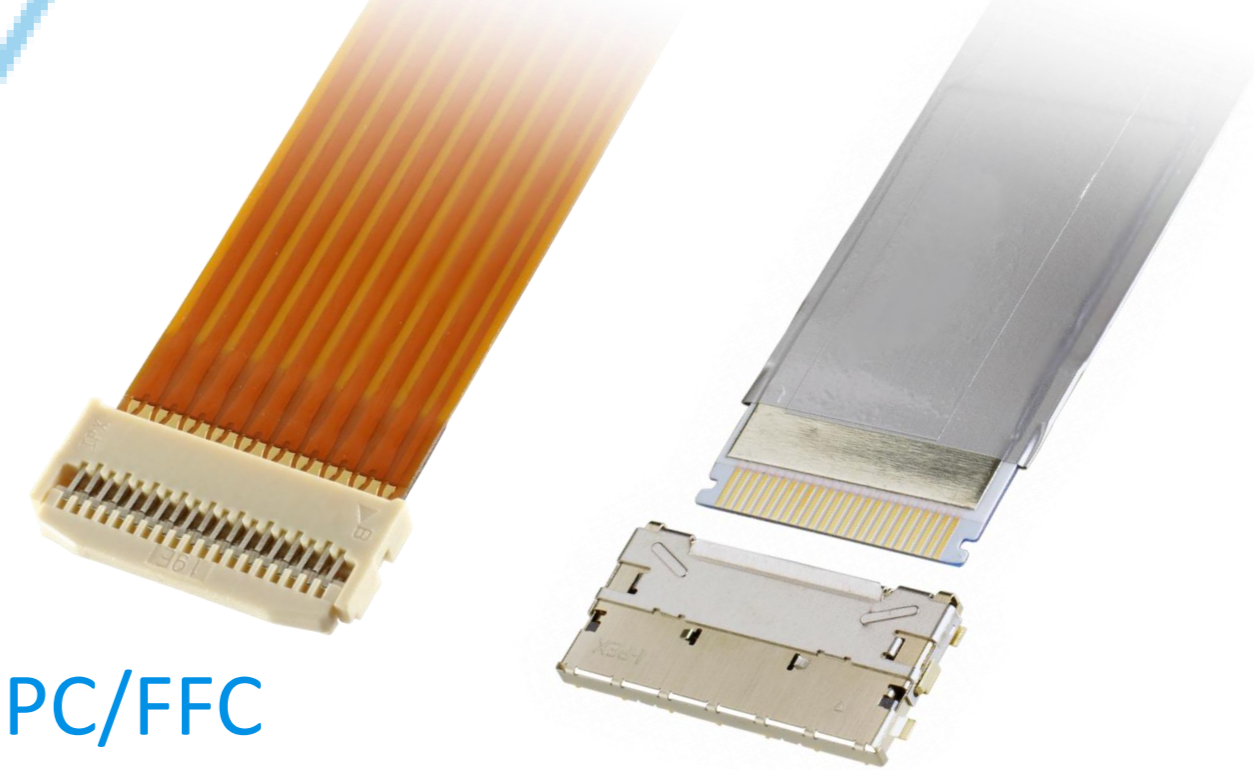

FPC/FFC Connectors



Inquiry



I-PEX, MHF, CABLINE, NOVASTACK, ISH, IARPB, MINIFLEX, EVAFLEX, MINIDOCK and ZenShield are registered trademarks of I-PEX Inc. Please note that the contents in the catalog might be changed without prior notification. I-PEX Inc. assumes no responsibility for any inaccuracies or obligation to update information on these documents. Please be sure to read and understand the latest "Precautions for Use" and "Instruction Manual" before you use our products. We shall not be responsible for any defects, damages or troubles in case you use our products without following the precautions for use. Please feel free to contact our sales representatives when you use our products for any applications that require very high reliability and safety, or that relate to human life (ex. nuclear power control, aerospace, transportation, medical equipment, safety equipment etc.).

Contact your sales representative or more detailed information.

www.i-pex.com



I-PEX

© I-PEX Inc. 2025
All rights reserved