

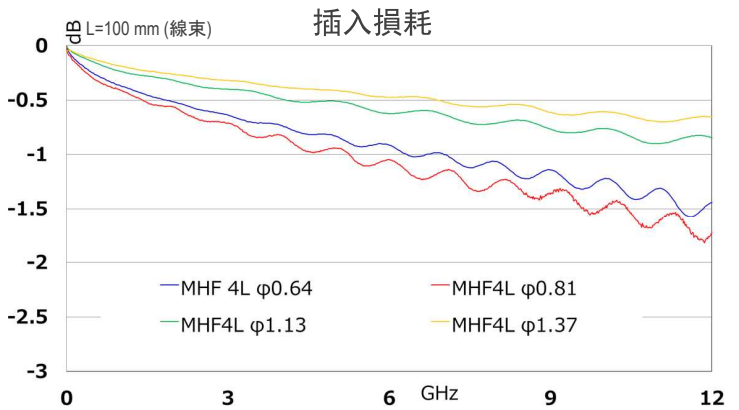

- ✓ 對應12 GHz 的高性能小型連接器
- ✓ 使用 “i-Fit[®]” 技術的無焊料極細同軸線終端
- ✓ 極細同軸線外徑 (AWG) : 1.13 mm (32), 0.95 mm (33)

Maximum height (mm)	1.4	
Outside dimension of receptacle (mm)	2.0 x 2.0	
Applicable wire gauge	O.D. 1.13 mm / AWG 32 O.D. 0.95 mm / AWG 33	
Frequency	DC~12 GHz	
VSWR (L=100 mm)	DC~3 GHz	1.3 max.
	3 GHz~6 GHz	1.45 max.
	6 GHz~9 GHz	1.6 max.
	9 GHz~12 GHz	1.9 max.
	12 GHz~15 GHz	-
Service temp. (Celsius)	-40 degree ~ +90 degree	
Characteristic impedance	50 ohm	
Rated voltage	AC60V	
Contact resistance	20m ohm max.	
Withstand voltage	AC200V/min	
Insulation resistance	500M ohm min./DC100V	

對應12 GHz 的高性能小型連接器

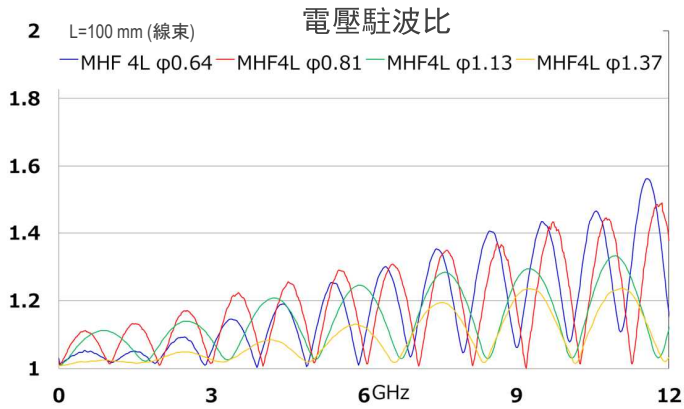

使用 “i-Fit[®]” 技術的無焊料極細同軸線終端

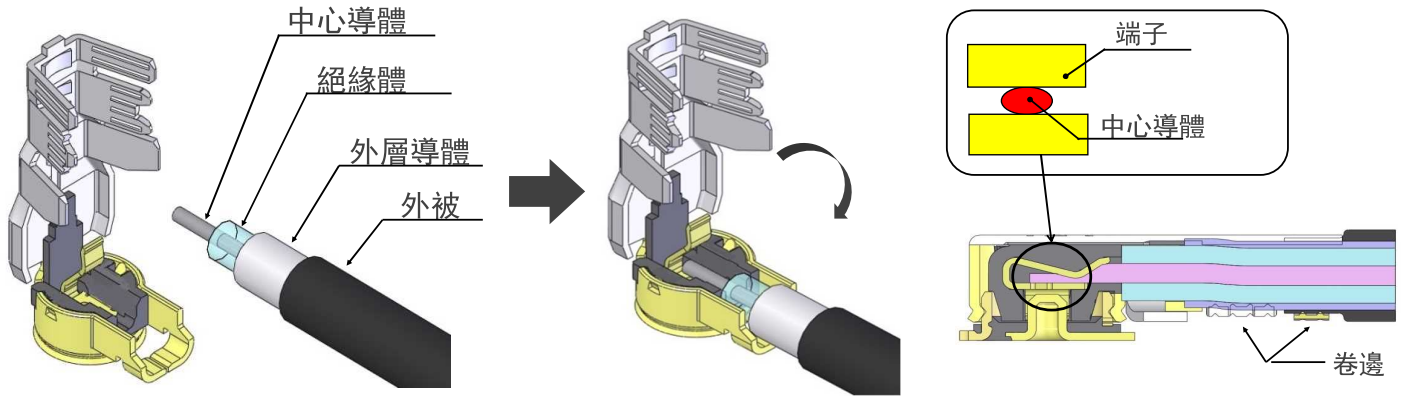

極細同軸線外徑 (AWG) : 1.13 mm (32), 0.95 mm (33)

同軸線外徑 (中心導體 AWG)	組合高度		
	最大 1.7 mm	最大 1.4 mm	最大 1.2 mm
2.00 mm (26)			
1.80 mm (30)			
1.37 mm (30)	○		
1.32 mm (32)			
1.13 mm (32)		○	
0.95 mm (33)		○	
0.81 mm (33)			
0.81 mm (36)			○
0.64 mm (36)			○
0.48 mm (38)			
母座	MHF 4 母座, MHF 4L 母座		

MHF[®] 4L

Component Parts Detail

MHF[®] 4L plug Ni top (1.13,0.95)

Recommended P/N	20565-001R-13
PART NO.	20565-001R-13

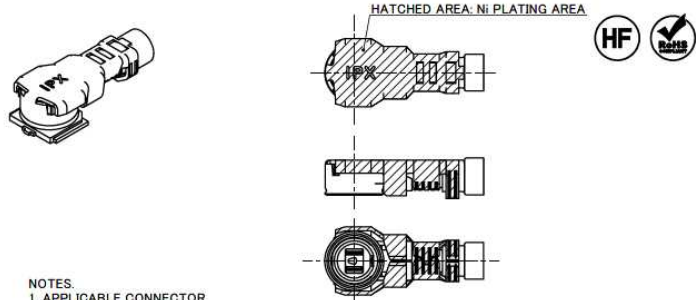
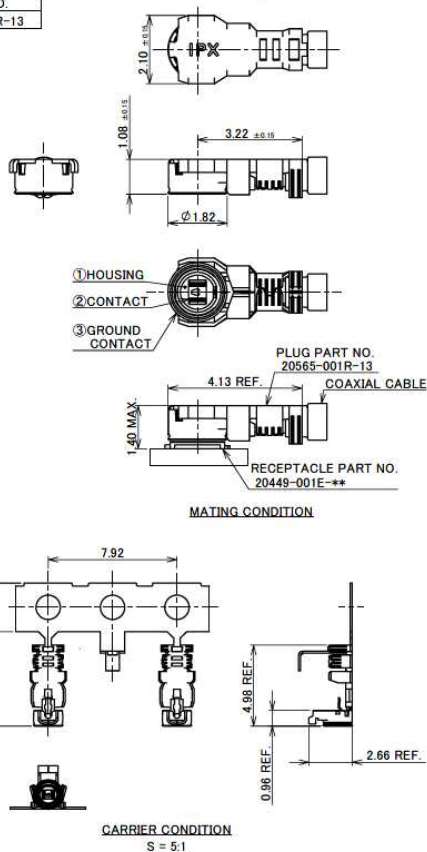

- NOTES.
- APPLICABLE CONNECTOR
20449-001E-***
20579-001E-***
 - MATING AND UNMATING INSTRUCTION
 - MATING
MATE THE CONNECTOR VERTICALLY AS MUCH AS POSSIBLE, ADJUSTING THE MATING AXIS OF PLUG AND RECEPTACLE. DO NOT SLANT MATE.
 - UNMATING INSTRUCTION
2-2-1. IN CASE OF UNMATING BY PULLING TOOL (PART NO. 90609-0001)
USE THE PULLING TOOL AS THE FOLLOWING DRAWING, AND PULL PLUG TO VERTICAL DIRECTION AS DIRECTLY AS POSSIBLE.
 - 2-2-2. IN CASE OF UNMATING DIRECTLY BY HAND
CATCH THE CATCHING AREA OF PLUG, AND PULL PLUG TO VERTICAL DIRECTION AS DIRECTLY AS POSSIBLE.

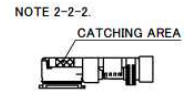
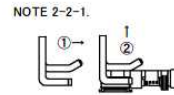
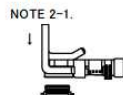

NO.	DESCRIPTION	MATERIAL	FINISH . REMARKS
3	GROUND CONTACT	PHOSPHOR BRONZE	ALL OVER Ni 1.00 μm MIN. CONTACT PART Au 0.05 μm MIN. [Ni PLATING AREA] Ni ONLY
2	CONTACT	PHOSPHOR BRONZE	ALL OVER Ni 1.00 μm MIN. CONTACT PART Au 0.10 μm MIN.
1	HOUSING	PBT	UL94V-0, BLACK

MHF® 4L plug Ni top (1.13,0.95)

Recommended P/N	20565-001R-83
PART NO.	20565-001R-83

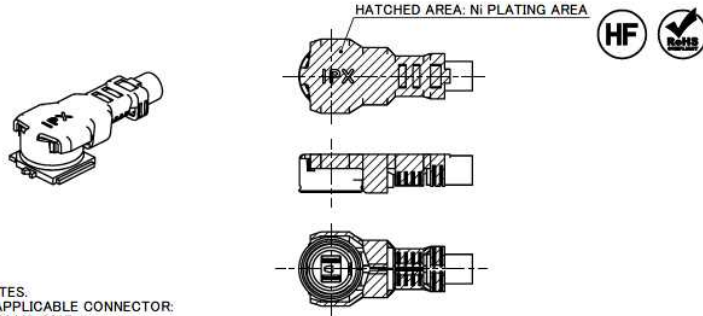
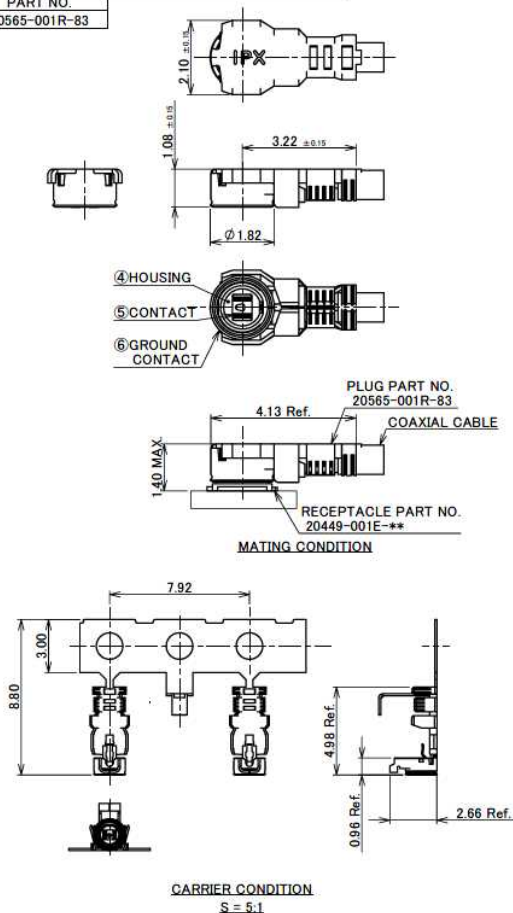

NOTES:
 3. APPLICABLE CONNECTOR:
 20449-001E-**
 20579-001E-**
 4. MATING AND UNMATING INSTRUCTION
 4-1. MATING
 MATE THE CONNECTOR VERTICALLY AS MUCH AS POSSIBLE, ADJUSTING THE MATING AXIS OF PLUG AND RECEPTACLE. DO NOT SLANT MATE.
 4-2. UNMATING INSTRUCTION
 4-2-1. IN CASE OF UNMATING BY PULLING TOOL (PART NO. 90609-0001)
 USE THE PULLING TOOL AS THE FOLLOWING DRAWING, AND PULL PLUG TO VERTICAL DIRECTION AS DIRECTLY AS POSSIBLE.
 4-2-2. IN CASE OF UNMATING DIRECTLY BY HAND
 CATCH THE CATCHING AREA OF PLUG, AND PULL PLUG TO VERTICAL DIRECTION AS DIRECTLY AS POSSIBLE.

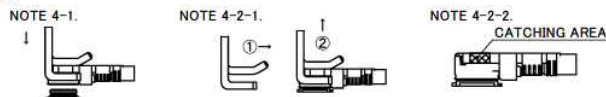

6	GROUND CONTACT	PHOSPHOR BRONZE	ALL OVER Ni: 1.00 μm MIN. CONTACT PART Au 0.05 μm MIN. [Ni PLATING AREA] Ni: ONLY
5	CONTACT	PHOSPHOR BRONZE	CONTACT PART FINISH: Au 0.10 μm MIN. UNDER PLATE: Ni 1.00 μm MIN.
4	HOUSING	PBT	UL94V-0, BLACK
NO.	DISCRIPTION	MATERIAL	FINISH , REMARKS

Confidential C

Rev.7

MHF® 4L plug Ni top (1.13,0.95)

ITEMS	SPECIFICATION		
	AWG#32 (1.13 O.D.)	AWG#33 (0.95 O.D.)	AWG#34 (0.83 O.D.)
APPLICABLE CABLE	AWG#32 (1.13 O.D.)	AWG#33 (0.95 O.D.)	AWG#34 (0.83 O.D.)
RECOMMENDED APPLICABLE CONNECTOR PART No.	20449-001E-**		
RATING VOLTAGE	60 V AC (R.M.S)		
RATING FREQUENCY	DC ~ 12GHz		
OPERATING TEMPERATURE	233 ~ 363 K (-40°C ~ +90°C)		
VSWR	1.3 MAX. AT DC ~ 3GHz, 1.45 MAX. AT 3 ~ 6GHz, 1.6 MAX. AT 6 ~ 9GHz, 1.9 MAX. AT 9 ~ 12GHz		
MAIN CONTACT RESISTANCE	INITIAL: 20 mohm MAX. / AFTER TEST: ΔR 20 mohm MAX.		
GROUND CONTACT RESISTANCE	INITIAL: 20 mohm MAX. / AFTER TEST: ΔR 20 mohm MAX.		
INSULATION RESISTANCE	INITIAL: 500 Mohm MIN. / AFTER TEST: 100 Mohm MIN.		
DIELECTRIC WITHSTANDING VOLTAGE	200 V AC, 1 MINUTE		
DURABILITY	30 CYCLES		
MATING FORCE (INITIAL / AFTER TEST)	INITIAL: 30 N MAX. / AFTER TEST: 30 N MAX.		
UNMATING FORCE (INITIAL / AFTER TEST)	INITIAL: 20 N MAX, 5 N MIN. / AFTER TEST: 20 N MAX, 3 N MIN.		
PRODUCT SPECIFICATION	PRS-1772	PRS-2051	PRS-2062
TEST REPORT	TR-13011	TR-14142	TR-15011
PACKING STANDARD	PST-12066		
INSTRUCTION MANUAL	HIM-12012		
APPEARANCE CRITERIA No.	GLS-A***		

Rev.7

MHF® 4L plug Ni top (1.13,0.95)

PART NO.	20565-001R-13	
APPLICABLE CABLE STRIP DIMENSION		
	※DO NOT USE SOLDER COATED EITHER INNER OR OUTER CONDUCTOR CABLES.	
	REQUIREMENTS CHARACTERISTIC IMPEDANCE: 50 ohm by TDR METHOD NOMINAL CAPACITANCE (REFERENCE VALUE): 97pF/m CONDUCTOR RESISTANCE OF INNER CONDUCTOR AT 293K (REFERENCE VALUE): OD 1.13 TYPE...520 ohm/km OD 0.95 TYPE...752 ohm/km INSULATION RESISTANCE: OD1.13 TYPE...1500 Mega-ohm.km MIN. OD0.95 TYPE...1000 Mega-ohm.km MIN. DIELECTRIC WITHSTAND VOLTAGE: OD1.13 TYPE...NO BREAKDOWN AT AC1000V FOR 1 MINUTE. OD0.95 TYPE...NO BREAKDOWN AT AC500V FOR 1 MINUTE.	
BRAIDED SHIELD OF OUTER CONDUCTOR	SINGLE BRAIDED SHIELD	SINGLE BRAIDED SHIELD
PART NO. OF SEMI AUTO TERMINATION MACHINE	90600-013	90600-010
	※USE FOR POINT MICROMETER.	
CRIMP HEIGHT		
	CH-1 (i-Fit® PART) 1.07~1.11	CH-2 (SHIELD PART) 0.90~0.94
	CH-3 (JACKET PART) 1.16~1.20	CH-1 (i-Fit® PART) 1.04~1.08
	CH-2 (SHIELD PART) 0.92~0.96	CH-3 (JACKET PART) 1.16~1.20

Rev.7

MHF® 4L plug Ni top (1.13,0.95)

PART NO.	20565-001R-83		
APPLICABLE CABLE STRIP DIMENSION			
	※DO NOT USE SOLDER COATED EITHER INNER OR OUTER CONDUCTOR CABLES.		
	REQUIREMENTS CHARACTERISTIC IMPEDANCE: 50 ohm BY TDR METHOD NOMINAL CAPACITANCE (REFERENCE VALUE): 96pF/m CONDUCTOR RESISTANCE OF INNER CONDUCTOR AT 293K (Reference value): 925 ohm/km INSULATION RESISTANCE: 1000 Mega-ohm.km MIN. DIELECTRIC WITH STANCE VOLTAGE: NO BREAKDOWN AT AC 1500V FOR 1 MINUTE.		
BRAIDED SHIELD OF OUTER CONDUCTOR	SINGLE BRAIDED SHIELD		
PART NO. OF SEMI AUTO TERMINATION MACHINE	90600-083		
	※USE FOR POINT MICROMETER.		
CRIMP HEIGHT			
	CH-1 (i-Fit® PART) 0.91~0.95	CH-2 (SHIELD PART) 0.84~0.88	CH-3 (JACKET PART) 0.82~0.86

Rev.7

Accessories for MHF® 4L (1.13,0.95)



MHF 4 (4L) SMA ADAPTOR
PART NO. 90449-001



MHF 4 (4L) INSPECTION CONNECTOR
PART NO. 90449-003-01



FRONT SIDE



BACK SIDE

MHF 4L PUSHING AND PULLING TOOL
PART NO. 90609-0001

Rev.7

MHF® 4L Receptacle

Recommended P/N	20579-001E
PART NO.	PACKING QUANTITY / REEL
20579-001E	10,000 PCS.
20579-001E-01	20,000 PCS.

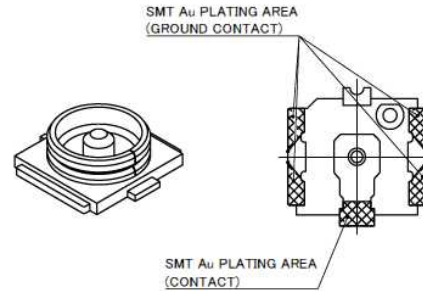
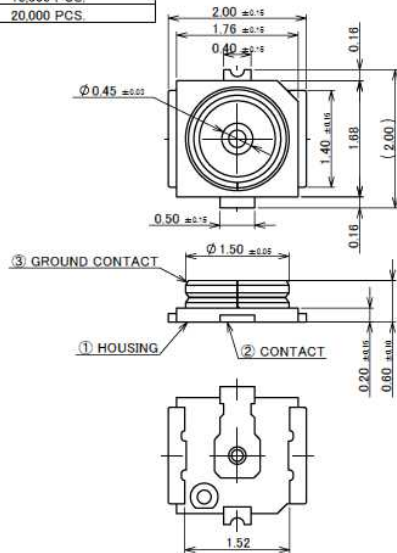

NOTES

- APPLICABLE CONNECTOR (CABLE SIZE)
 - MHF 4 PLUG: 20611-001R ($\varnothing 0.81$), 20448-00*R-081 ($\varnothing 0.81$), 20448-001R-081E ($\varnothing 0.81$)
 - MHF 4L PLUG: 20572-001R-08 ($\varnothing 0.64$, $\varnothing 0.81$), 20565-001R-** ($\varnothing 0.83$, $\varnothing 0.95$, $\varnothing 1.13$), 20632-001R-37 ($\varnothing 1.37$)
 - MHF 4 SMT PUG: 20462-001E
- COPLANARITY: 0.1 mm MAX.

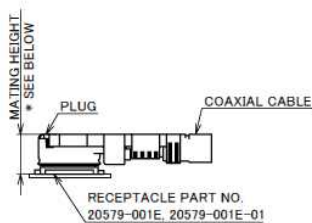

- * MATING HEIGHT
- 1.2 MAX. WITH 20611-001R, 20572-001R-08, 20448-00*R-081, 20448-001R-081E
 - 1.4 MAX. WITH 20565-001R-**
 - 1.7 MAX. WITH 20632-001R-37

MATING CONDITION
WITH MHF 4/MHF 4L PLUG
(S = 10/1)

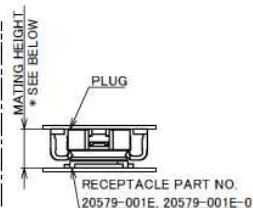

- * MATING HEIGHT
- 1.2 MAX. WITH 20462-001E

MATING CONDITION
WITH MHF 4 SMT
(S = 10/1)

NO.	DESCRIPTION	MATERIAL	FINISH . REMARKS
3	GROUND CONTACT	PHOSPHOR BRONZE	ALL OVER Ni: 1.00 μ m MIN. CONTACT PART: Au 0.05 μ m MIN. . SOLDERING PART Au AREA: 0.03 μ m MIN.
2	CONTACT	BRASS	ALL OVER Ni: 1.00 μ m MIN. CONTACT PART: Au 0.05 μ m MIN. SOLDERING PART Au AREA: 0.03 μ m MIN.
1	HOUSING	LCP	UL94V-0, BLACK

Rev.8

MHF® 4L Receptacle

FOR MHF 4L PLUG

ITEMS	SPECIFICATION	
	20572-001R-08 (CABLE Φ0.81 TYPE)	20565-001E-13 (CABLE Φ 1.13 TYPE)
APPLICABLE CONNECTOR PART No.		
RATING VOLTAGE	60 V AC (R.M.S)/DC	
RATING FREQUENCY	DC ~ 6GHz	
OPERATING TEMPERATURE	233~363 K(-40°C~+90°C)	
VSWR	1.3 MAX. AT DC~3GHz, 1.4 MAX. AT 3~6GHz, 1.85 MAX. AT 3~12GHz	
MAIN CONTACT RESISTANCE	INITIAL : 20 mohm MAX. / AFTER TEST : ΔR 20 mohm MAX.	
GROUND CONTACT RESISTANCE	INITIAL : 20 mohm MAX. / AFTER TEST : ΔR 20 mohm MAX.	
INSULATION RESISTANCE	INITIAL : 500 Mohm MIN. / AFTER TEST : 100 Mohm MIN.	
DIELECTRIC WITHSTANDING VOLTAGE	200 V AC 1 MINUTE	
DURABILITY	30 CYCLES	
MATING FORCE (INITIAL / AFTER TEST)	INITIAL : 30 N MAX. / AFTER TEST : 30 N MAX.	
UNMATING FORCE (INITIAL / AFTER TEST)	INITIAL : 20 N MAX. 5 N MIN. / AFTER TEST : 20 N MAX. 3 N MIN.	
PRODUCT SPECIFICATION	PRS-1907	
TEST REPORT	TR-14097	
PACKING STANDARD	20579-001E: PST-14004 20579-001E-01: PST-14067	
INSTRUCTION MANUAL	HIM-12011	HIM-12012

Rev.8

MHF® 4L Receptacle

FOR MHF 4 SMT PLUG

ITEMS	SPECIFICATION	
	20462-001E (MHF 4 SMT PLUG)	
APPLICABLE CONNECTOR PART No.		
RATING VOLTAGE	60 V AC (R.M.S)/DC	
RATING FREQUENCY	DC~6GHz	
OPERATING TEMPERATURE	233~363 K(-40°C~+90°C)	
VSWR	1.3 MAX. AT DC~3GHz, 1.4 MAX. AT 3~6GHz, 1.85 MAX. AT 3~12GHz	
MAIN CONTACT RESISTANCE	INITIAL : 20 mohm MAX. / AFTER TEST : ΔR 20 mohm MAX.	
GROUND CONTACT RESISTANCE	INITIAL : 20 mohm MAX. / AFTER TEST : ΔR 20 mohm MAX.	
INSULATION RESISTANCE	INITIAL : 500 Mohm MIN. AFTER TEST : 100 Mohm MIN.	
DIELECTRIC WITHSTANDING VOLTAGE	200 V AC 1 MINUTE	
DURABILITY	30 CYCLES	
MATING FORCE (INITIAL / AFTER TEST)	INITIAL : 30 N MAX. / AFTER TEST : 15 N MAX.	
UNMATING FORCE (INITIAL / AFTER TEST)	INITIAL : 4 N MIN. / AFTER TEST : 2 N MIN.	
PRODUCT SPECIFICATION	PRS-1404	
TEST REPORT	TR-08022	
PACKING STANDARD	20579-001E: PST-14004 20579-001E-01: PST-14067	

Rev.8

MHF® 4L Receptacle

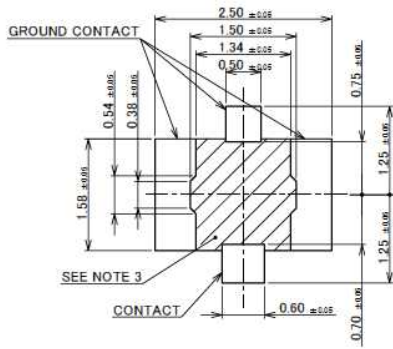

RECOMMENDED FOOTPRINT PATTERN

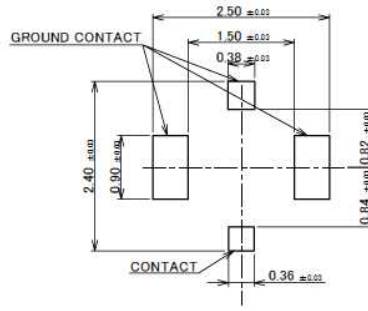

RECOMMENDED METAL MASK LAYOUT

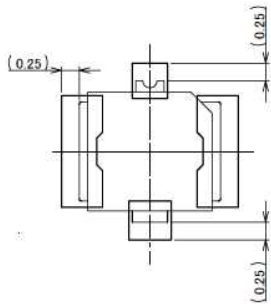

CONNECTOR ON RECOMMENDED FOOTPRINT PATTERN

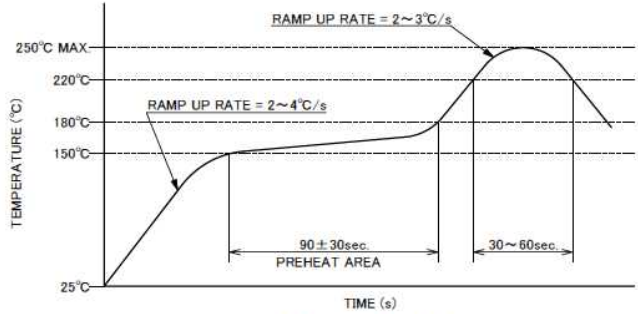

REFLOW TEMPERATURE PROFILE
SENJU METAL INDUSTRY CO., LTD. M705-SHF(Sn96.5 Ag3.0 Cu0.5)

NOTE 3. CUT OUT PROHIBITION AREA.

Rev.8

MHF® 4 Receptacle

Recommended P/N 20449-001E-03

PART NO.	PACKING QUANTITY / REEL	CONTACT PLATING			GROUND CONTACT PLATING		
		CONTACT PART	SOLDERING PART	ALL OVER	CONTACT PART	SOLDERING PART	ALL OVER
20449-001E	10,000 PCS.	TOP: Au 0.05 μm MIN. ZONE X: Au 0.03 μm MIN.	TOP: Au 0.01 μm MIN.	Ni 1.00 μm MIN.	TOP: Au 0.03 μm MIN.	TOP: Au 0.01 μm MIN.	Ni 1.00 μm MIN.
20449-001E-01		TOP: Au 0.05 μm MIN.					
20449-001E-03		TOP: Au 0.01 μm MIN. MIDDLE: Pd-Ni 0.02 μm MIN.	TOP: Au 0.01 μm MIN. MIDDLE: Pd-Ni 0.02 μm MIN.		TOP: Au 0.01 μm MIN. MIDDLE: Pd-Ni 0.02 μm MIN.	TOP: Au 0.01 μm MIN. MIDDLE: Pd-Ni 0.02 μm MIN.	

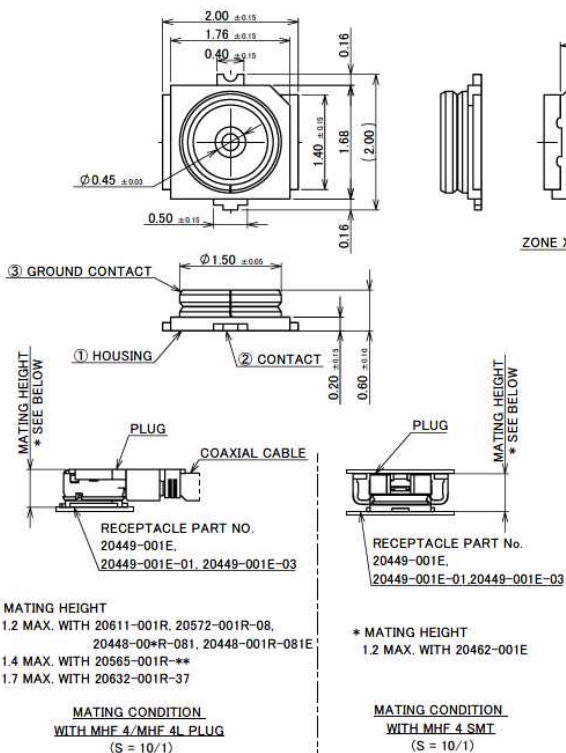

NOTES.

1. APPLICABLE CONNECTOR (CABLE SIZE)
MHF 4 PLUG: 20611-001R (Φ0.81), 20448-00*R-081 (Φ0.81), 20449-001R-081E (Φ0.81)
MHF 4L PLUG: 20572-001R-08 (Φ0.84, Φ0.81), 20565-001R-** (Φ0.83, Φ0.95, Φ1.13), 20632-001R-37 (Φ1.37)
MHF 4 SMT PLUG: 20462-001E
2. COPLANARITY: 0.1 mm MAX.
3. THIS IS "Pb-FREE" CONNECTOR.
4. CHARACTERISTIC IMPEDANCE: 50 Ω (NOMINAL VALUE)

NO.	DESCRIPTION	MATERIAL	FINISH, REMARKS
3	GROUND CONTACT	PHOSPHOR BRONZE	SEE TABLE
2	CONTACT	BRASS	SEE TABLE
1	HOUSING	LCP	UL94V-0, BLACK

Confidential C

Rev.15

MHF® 4 Receptacle

FOR MHF 4 PLUG

ITEMS	SPECIFICATION	
	20611-001R (CABLE Ø0.81 TYPE)	20448-001R (CABLE Ø0.81 TYPE)
APPLICABLE CONNECTOR PART No.		
RATING VOLTAGE	60 V AC (R.M.S.)/DC	
RATING FREQUENCY	DC~9GHz	
OPERATING TEMPERATURE	233~363 K (-40°C~+90°C)	
CHARACTERISTIC IMPEDANCE	50 ohm (NOMINAL VALUE)	
VSWR	1.3 MAX. AT DC~3GHz, 1.4 MAX. AT 3~6GHz, 1.5 MAX. AT 6~9GHz	
MAIN CONTACT RESISTANCE	INITIAL : 20 mohm MAX. / AFTER TEST : Δ R 20 mohm MAX.	
GROUND CONTACT RESISTANCE	INITIAL : 20 mohm MAX. / AFTER TEST : Δ R 100 mohm MAX.	INITIAL : 20 mohm MAX. / AFTER TEST : Δ R 20 mohm MAX.
INSULATION RESISTANCE	INITIAL : 500 Mohm MIN. / AFTER TEST : 100 Mohm MIN.	
DIELECTRIC WITHSTANDING VOLTAGE	200 V AC 1 MINUTE	
DURABILITY	30 CYCLES	
MATING FORCE (INITIAL / AFTER TEST)	-	
UNMATING FORCE (INITIAL / AFTER TEST)	INITIAL : 4 N MIN. / AFTER TEST : 2 N MIN.	
PRODUCT SPECIFICATION	PRS-2530	PRS-1745
TEST REPORT	TR-18086	TR-12118
PACKING STANDARD	20449-001E-03: 300-604	
INSTRUCTION MANUAL	HIM-10003	
APPEARANCE CRITERIA No.	QLS-A***	

Rev.15

MHF® 4 Receptacle

FOR MHF 4L PLUG

ITEMS	SPECIFICATION			
	20572-001R-08 (CABLE Ø0.64 TYPE) (CABLE Ø0.81 TYPE)	20565-001E-13 (CABLE Ø0.95 TYPE) (CABLE Ø1.13 TYPE)	20565-001R-83 (CABLE Ø0.83 TYPE)	20632-001R-37 (CABLE Ø1.37 TYPE)
APPLICABLE CONNECTOR PART No.				
RATING VOLTAGE	60 V AC (R.M.S.)/DC			
RATING FREQUENCY	DC ~ 9GHz			
OPERATING TEMPERATURE	233~363 K (-40°C~+90°C)			
CHARACTERISTIC IMPEDANCE	50 ohm (NOMINAL VALUE)			
VSWR	1.3 MAX. AT DC~3GHz, 1.4 MAX. AT 3~6GHz, 1.5 MAX. AT 6~9GHz			
MAIN CONTACT RESISTANCE	INITIAL : 20 mohm MAX. / AFTER TEST : Δ R 20 mohm MAX.			
GROUND CONTACT RESISTANCE	INITIAL : 20 mohm MAX. / AFTER TEST : Δ R 20 mohm MAX.			
INSULATION RESISTANCE	INITIAL : 500 Mohm MIN. / AFTER TEST : 100 Mohm MIN.			
DIELECTRIC WITHSTANDING VOLTAGE	200 V AC 1 MINUTE			
DURABILITY	30 CYCLES			
MATING FORCE (INITIAL / AFTER TEST)	INITIAL : 30 N MAX. / AFTER TEST : 30 N MAX.			
UNMATING FORCE (INITIAL / AFTER TEST)	INITIAL : 20 N MAX. 5 N MIN. / AFTER TEST : 20 N MAX. 3 N MIN.			
PRODUCT SPECIFICATION	PRS-1944 (CABLE Ø0.64 TYPE) PRS-1772 (CABLE Ø0.81 TYPE)	PRS-2051 (CABLE Ø0.95 TYPE) PRS-1772 (CABLE Ø1.13 TYPE)	PRS-2062 (CABLE Ø0.83 TYPE)	PRS-2008 (CABLE Ø1.37 TYPE)
TEST REPORT	TR-14078 (CABLE Ø0.64 TYPE) TR-13011 (CABLE Ø0.81 TYPE)	TR-14142 (CABLE Ø0.95 TYPE) TR-13011 (CABLE Ø1.13 TYPE)	TR-15011 (CABLE Ø0.83 TYPE)	TR-14100 (CABLE Ø1.37 TYPE)
PACKING STANDARD	20449-001E-03: 300-604			
INSTRUCTION MANUAL	HIM-12011	HIM-12012		HIM-16011
APPEARANCE CRITERIA No.	QLS-A***			

Rev.15

MHF[®] 4 Receptacle

FOR MHF 4 SMT PLUG

ITEMS	SPECIFICATION
APPLICABLE CONNECTOR PART No.	20462-001E (MHF 4 SMT PLUG)
RATING VOLTAGE	60 V AC (R.M.S)/DC
RATING FREQUENCY	DC~9GHz
OPERATING TEMPERATURE	233~363 K(-40°C~+90°C)
CHARACTERISTIC IMPEDANCE	50 ohm (NOMINAL VALUE)
VSWR	1.3 MAX. AT DC~3GHz, 1.4 MAX. AT 3~6GHz, 1.5 MAX. AT 6~9GHz
MAIN CONTACT RESISTANCE	INITIAL : 20 mohm MAX. / AFTER TEST : Δ R 20 mohm MAX.
GROUND CONTACT RESISTANCE	INITIAL : 20 mohm MAX. / AFTER TEST : Δ R 20 mohm MAX.
INSULATION RESISTANCE	INITIAL : 500 Mohm MIN. / AFTER TEST : 100 Mohm MIN.
DIELECTRIC WITHSTANDING VOLTAGE	200 V AC 1 MINUTE
DURABILITY	30 CYCLES
MATING FORCE (INITIAL / AFTER TEST)	INITIAL : 30 N MAX. / AFTER TEST : 15 N MAX.
UNMATING FORCE (INITIAL / AFTER TEST)	INITIAL : 4 N MIN. / AFTER TEST : 2 N MIN.
PRODUCT SPECIFICATION	PRS-1404
TEST REPORT	TR-08022
PACKING STANDARD	20449-001E-03: 300-604
INSTRUCTION MANUAL	HIM-15005
APPEARANCE CRITERIA No.	QLS-A***

Rev.15

MHF[®] 4 Receptacle

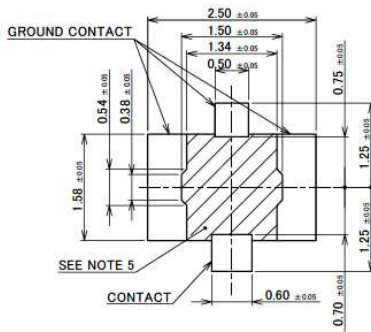

RECOMMENDED FOOTPRINT PATTERN

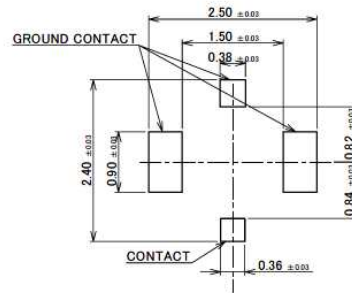

MASK THICKNESS: 0.12 mm

RECOMMENDED METAL MASK LAYOUT

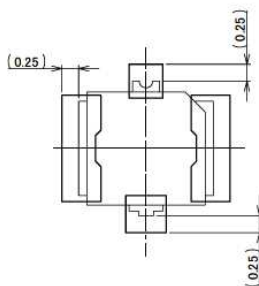

CONNECTOR ON RECOMMENDED FOOTPRINT PATTERN

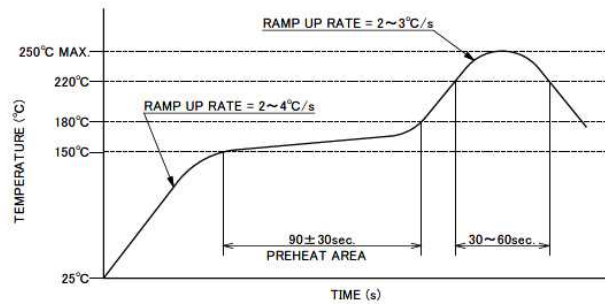

NOTE 5. CUT OUT PROHIBITION AREA.

Confidential C

Rev.15

Accessories for MHF® 4L Receptacle



MHF 4 (4L) SMA ADAPTOR
PART NO. 90449-002



MHF 4 SMA ADAPTOR HIGH CYCLE TYPE
PART NO. 90688-0001



MHF 4 RECEPTACLE NARROW PITCH
SMA ADAPTOR HIGH CYCLE TYPE
PART NO. 90576-0001

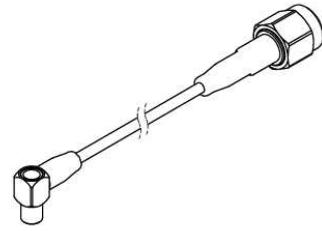

4.5MM HIGH CYCLE TEST PROBE CABLE ASS'Y
PART NO. 90577-****

* 90576-0001 AND 90577-**** SHOULD BE USED TOGETHER.

Rev.15

I-PEX

Copyright © I-PEX Inc. 2020. All rights reserved.

I-PEX, MHF, CABLINE, NOVASTACK, EVAFLEX, MINIFLEX, ISH, IARPB, IASLP, ESTORQ, i-Fit 以及 ISFIT 是 I-PEX 株式會社的註冊商標。請注意，目錄中的內容可能會在沒有事先告知的情況下進行更改。I-PEX 集團沒有義務和責任承擔這些檔中誤差和更新。使用我們的產品前，請務必正確閱讀和理解最新的“使用注意事項”和“使用說明書”。如果您在使用我們的產品時沒有遵循使用注意事項，我們將不對任何不良、損壞或故障負責。當您將我們的產品使用在任何需要較高可靠性和安全性，或者涉及生命安全的應用時，請提前聯繫我們的銷售代表。（例如：核電控制，航空航太，運輸，醫療設備，安全設備等）

請聯繫您當地的銷售代表，了解更詳細的信息 [i-pex.com]

202101R0