

CABLINE®-VS PLUG

Part No. 20453-#**T-###

Assembly Manual

10	S22436	October 4, 2022	K.Baba	R.Takei	H.Ikari
9	S21634	November 25, 2021	R.Morita	T.Masunaga	H.Ikari
8	S19014	January 8, 2019	Y.Miyazaki	T.Masunaga	H.Ikari
7	S18632	October 1, 2018	Y.Miyazaki	-	H.Ikari
Rev.	ECN	Date	Prepared by	Checked by	Approved by

1. Purpose :

This manual is to explain the soldering method / process of the CABLINE-VS PLUG with cable, and assembly of SHELL-A, PULL-BAR.

2. Applicable connector :

Name : CABLINE-VS PLUG

Parts No. :

Set P/N	CABLE ASS'Y	20453-##*T-###
Discrete P/N	HOUSING ASS'Y	20454-##*T-##
	SHELL-A	2574-##*#
	PULL-BAR	2576-##*##

3. Fixtures :

3.1 Components and Instruments used in the condition confirmation

- Pulse heater

Name	P/N	Manufacturer
Reflow head	NA-66	Nippon Avionics Co.,Ltd.
Pulse heat power supply	TCW-215	Nippon Avionics Co.,Ltd.

- Heater chip

	20P	30P	40P	50P
Thickness	0.5 ⁰ _{-0.05}	0.5 ⁰ _{-0.05}	0.5 ⁰ _{-0.05}	0.5 ⁰ _{-0.05}
Width	10.0 ⁰ _{-0.03}	15.0 ⁰ _{-0.03}	20 ⁰ _{-0.03}	25 ⁰ _{-0.03}

Unit:mm

- Recommended solder bar

Resin-free solder made by Uchihashi Estec Co.,Ltd. was used.

Positions		20P	30P	40P	50P
Solder size	AWG#40~#44	φ0.1	φ0.1	φ0.1	φ0.1
	AWG#32~#36	φ0.14	φ0.14	φ0.14	φ0.14
Length		10.0mm Ref.	15.0mm Ref.	20.0mm Ref.	25.0mm Ref.

Unit:mm

4. Recommended pulse heat condition

	MICRO-COAX	Discrete
① Idle temp.	150°C	150°C
② 1 st heat temp.	220°C	220°C
③ " rise time	0.5sec.	0.5sec.
④ " holding time	3.0sec.	3.0sec.
⑤ 2 nd heat temp.	340~360°C	370~390°C
⑥ " rise time	0.5sec.	0.5sec.
⑦ " holding time	3.0sec.	3.0sec.
Heater tip Pressure	15~19N	15~19N

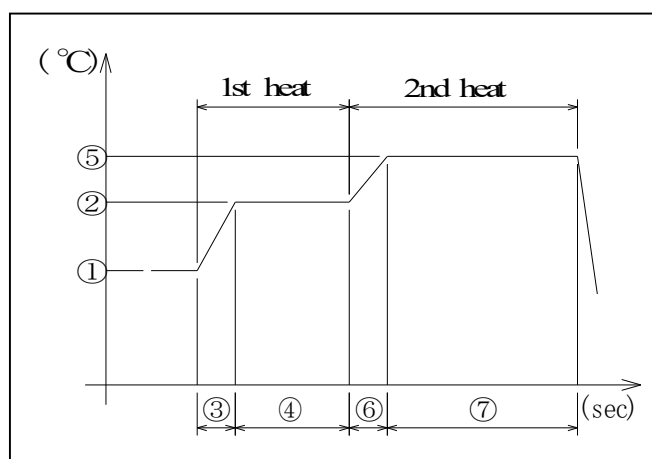

※ This pulse heat condition was evaluated and confirmed by our pulse heat jig and instruments.

The most optimum condition may change based on the shapes of pulse heat jig and instruments, the environments, or other reason.

Therefore, please examine the pulse heat condition adequately in advance of use.

5. Work procedures :

5-1. Soldering of center-conductor

① The cables have to be fabricated as shown below in advance of soldering.

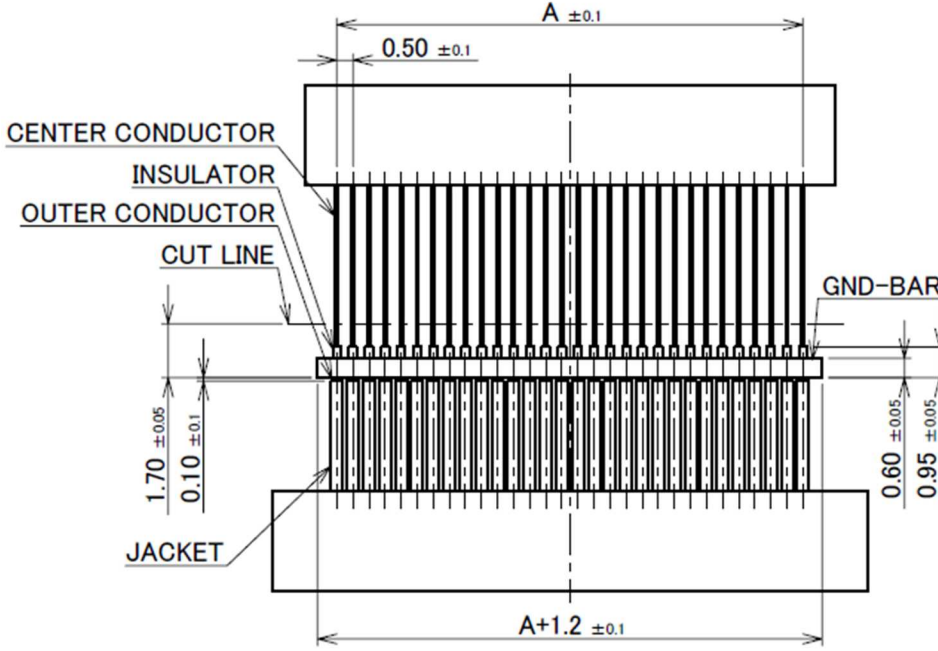

DIMENSION-A

Pos.	A
20P	9.50
30P	14.50
40P	19.50
50P	24.50

RECOMMENDED MICRO COAX CABLE DIMENSION

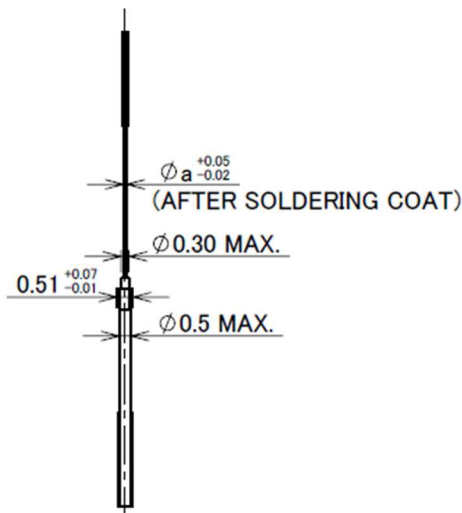

MICRO COAX CABLE DIMENSION

AWG	a
#36	0.15
#38	0.12
#40	0.09
#42	0.075
#44	0.063

MICRO COAX CABLE AWG #**

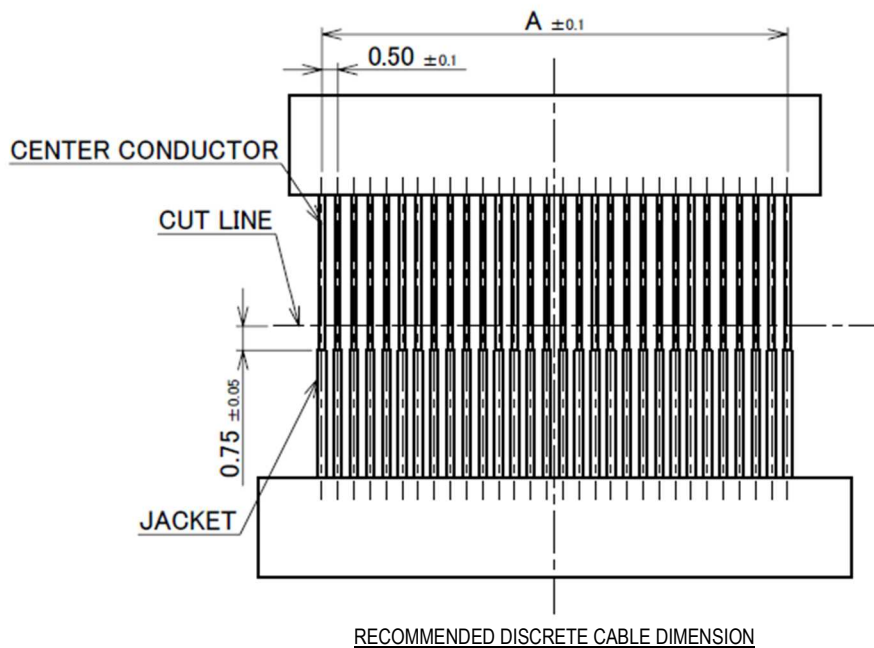

DIMENSION-A

Pos.	A
20P	9.50
30P	14.50
40P	19.50
50P	24.50

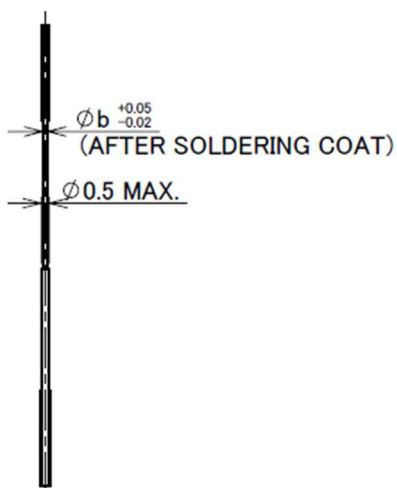

DISCRETE CABLE DIMENSION

AWG	b
#32	0.24
#34	0.192
#36	0.15

DISCRETE CABLE AWG #**

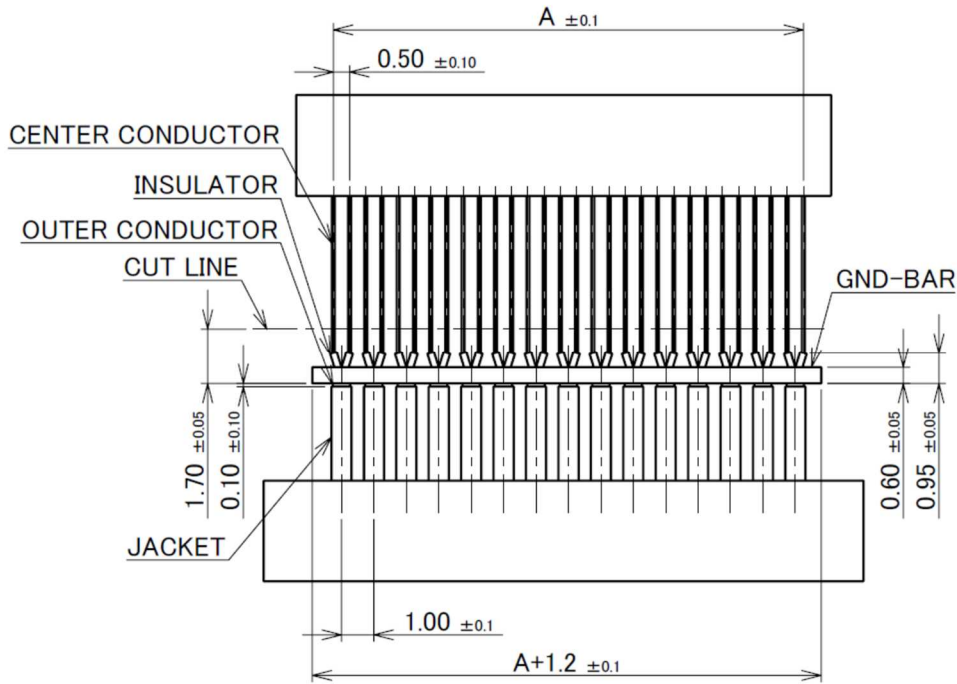

DIMENSION-A

Pos.	A
20P	9.50
30P	14.50
40P	19.50
50P	24.50

RECOMMENDED TWINCOAX DIMENSION

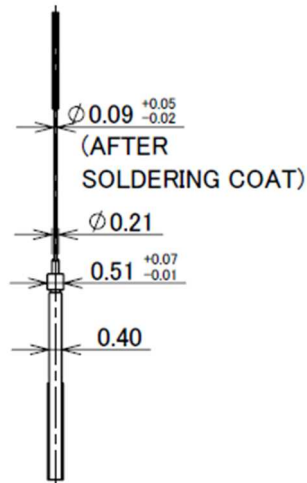

TWINCOAX CABLE AWG #40

②Apply flux to contact by the dispenser etc., and please confirm all contacts were applied flux.

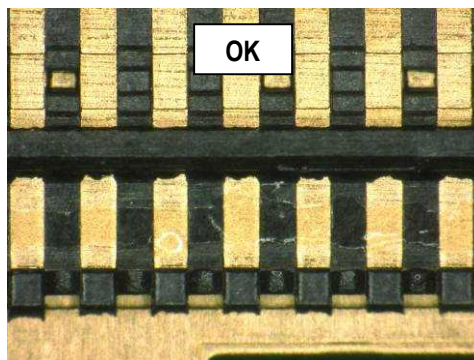
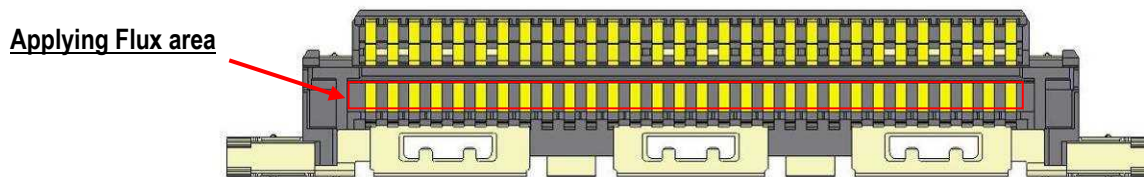

Photo.1 After applying flux

※Please do not apply flux too much like Photo.2. It can cause flux splash or leak to the mating area.

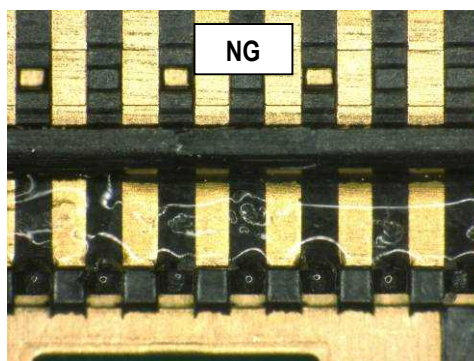

Photo.2 Extra flux

※Washer must not be used to take flux off because it may cause flux attached to mating area.

③ Pre-set and locate solder bar at center of connector (HSG ASS'Y).

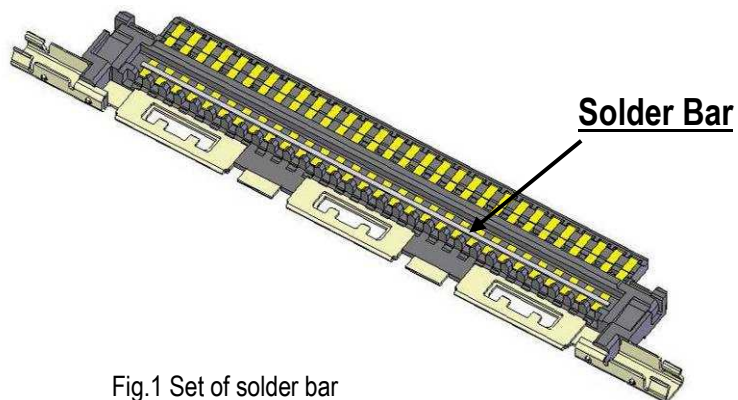

Fig.1 Set of solder bar

④ Set the cable.

※ Setting discrete cable is to protect 0.2MAX. as Fig.3. There is danger that Center Conductor touch SHELL.

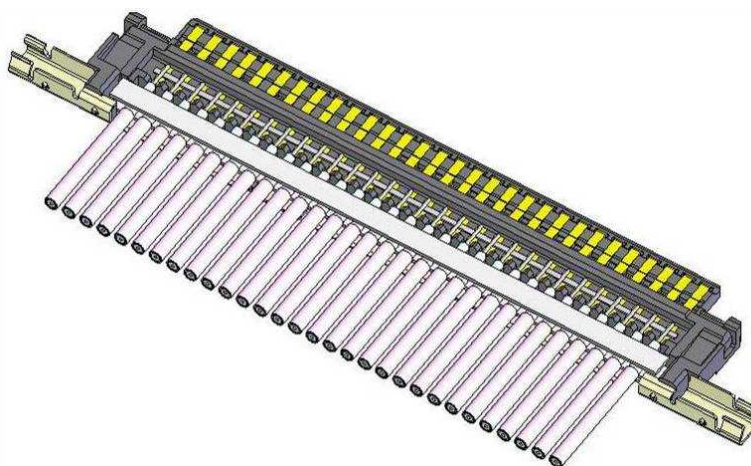

Fig.2 Set of cable

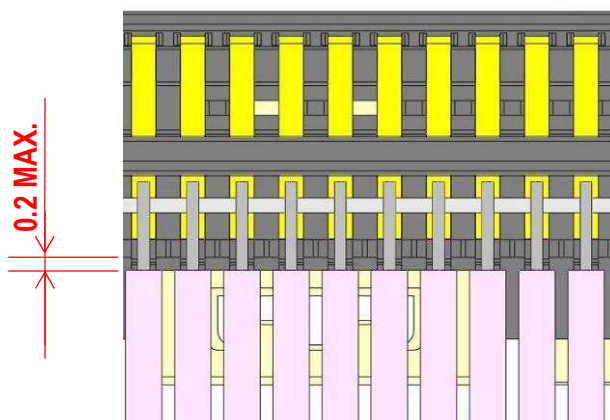

Fig.3 Setting Discrete Cable

⑤Center-conductors are soldered with pulse heater. See photo.3 of soldering condition.

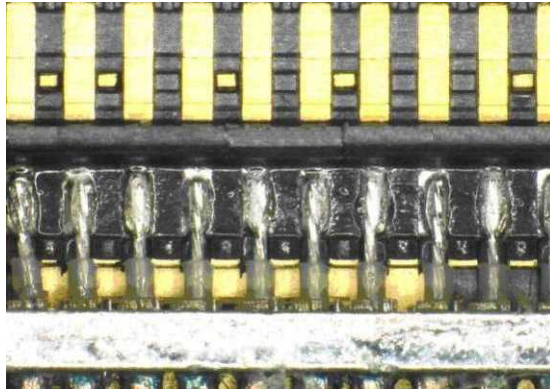

Photo.3 AWG#40

Caution: The SHELL bottom side of PLUG HSG ASS'Y has convex shape at the points shown in Fig.4, so please make escape shape on the receiving jig of the pulse heater to prevent interference.

	A	B
20P	—	16.0
30P	5.4	21.0
40P	10.4	26.0
50P	15.4	31.0

Unit:mm

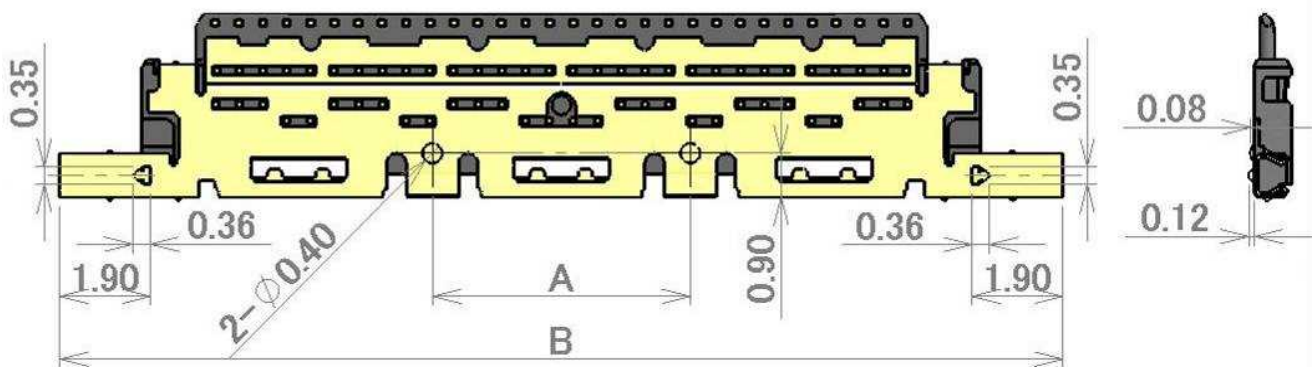

Fig.4 The SHELL bottom side of PLUG HSG ASS'Y

※When solder bridge is appeared between the terminal, try heating again with pulse heater only one time.

If the bridge isn't repaired, use the soldering iron only a NG point.

Condition of Soldering iron : 50W

Operating temperature : 350°C

Application time of soldering iron : Within 5sec.

※When there is much quantity of solder in hand soldering, and there might be the short circuit with SHELL-A, put an insulating tape in SHELL-A before assembly of SHELL-A.

Caution: Do not forcibly pull the cable toward red arrow direction after soldering or apply excessive load on the soldered area, or it may peel the solder. [Fig. 5]

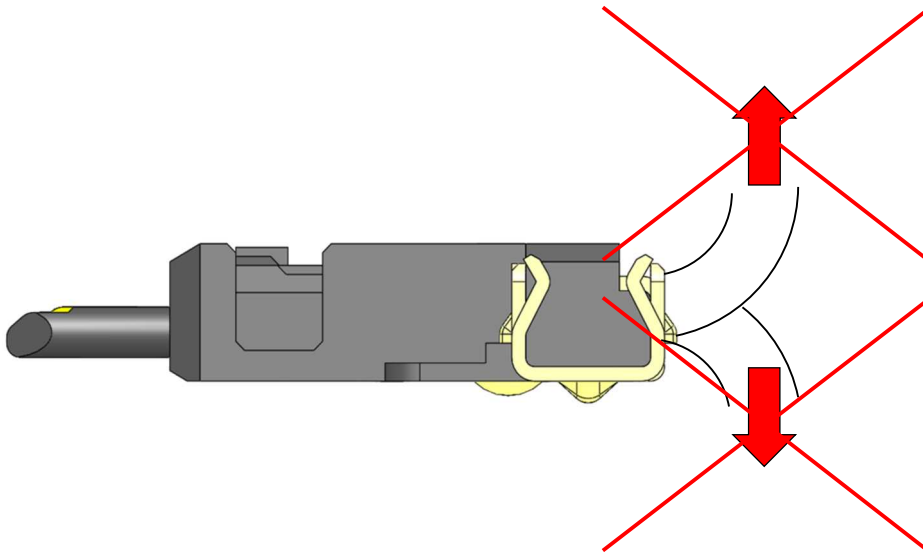
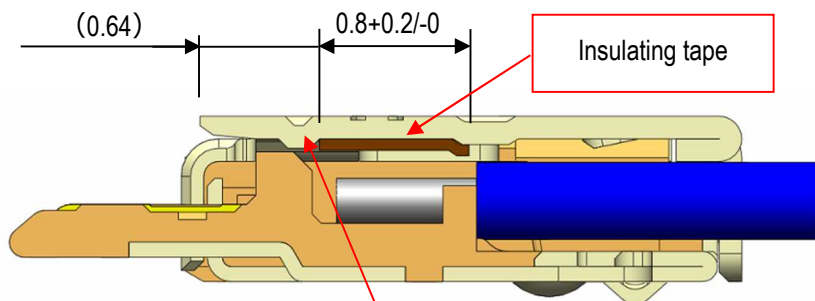

Fig.5 Cause of solder peeling

◆ Insulating tape thickness $t=0.06\text{mm}$

【SHELL-A P/N : 2574-#**】



Please avoid touching the convex point on SHELL-A fore-end.
It might cause the SHELL-A float.

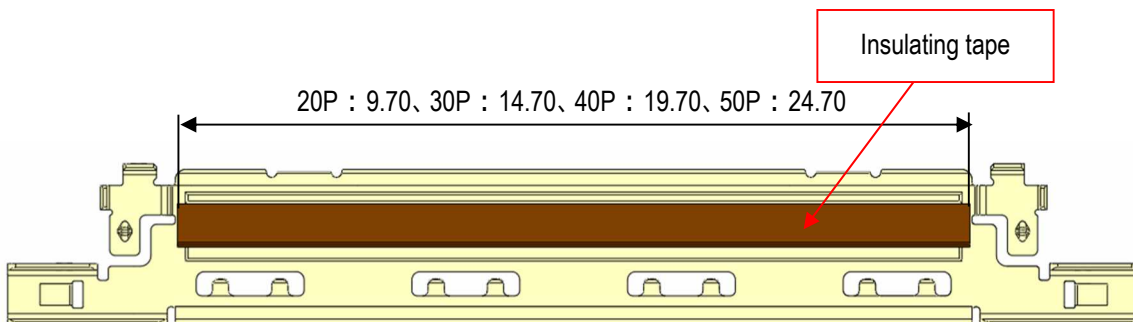

5-2. Cautions in treating SHELL-A

SHELL-A is delivered in the reel with a carrier. The following is the method to cut SHELL-A from Carrier.

Cut carrier on the cut line of a lower left picture (green line) by a scissors for metal.

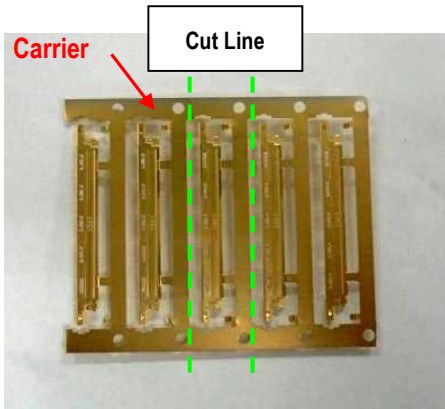

Photo 4. Before cut

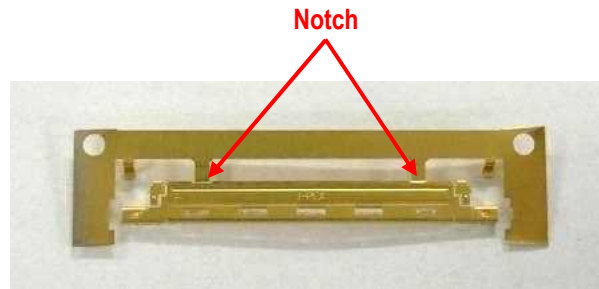

Photo 5. After cut

- ① Hold the center of Plug shell-A and cut it off from Notch by ± 45 deg of reciprocating work. When it does not be cut, try again this reciprocating work. After separated, check there is no burr around the cut part. (Photo.7)

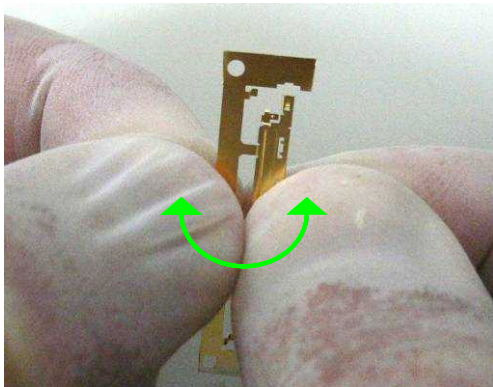
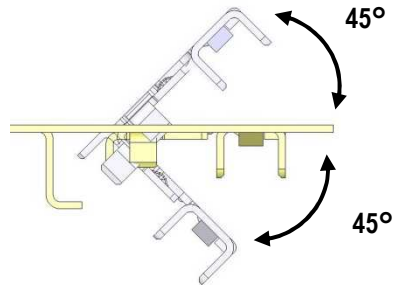

Photo 6. Cut condition



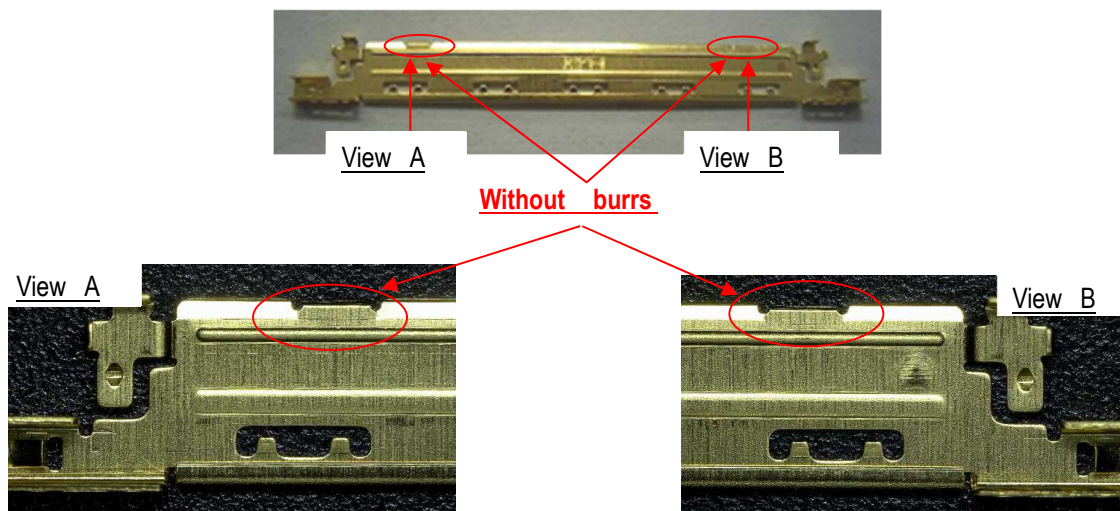

Photo.7 After cut

Plug SHELL-A Detail of Notch

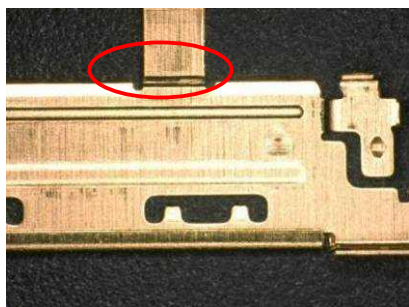

Photo 8. Bottom side view

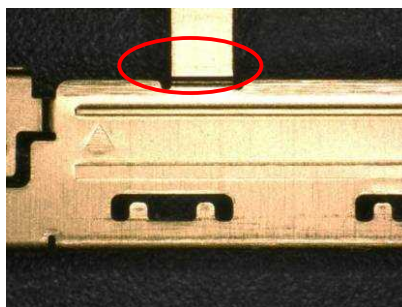

Photo 9. Upper side view

Caution: By pulling like a lower photo to cut off by force (Red arrow direction), burrs and transformation can be caused.

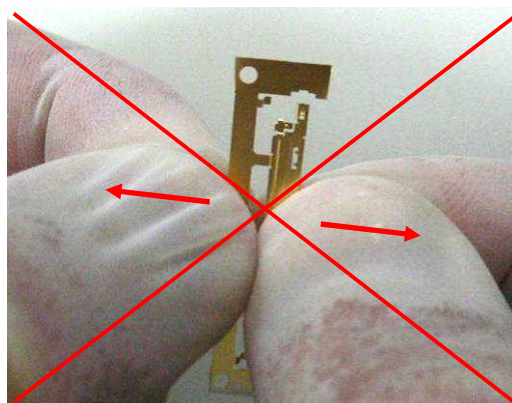

Photo 10. Cut by force (Bad example)

5-3. Assembly of PULL-BAR

• In case of WITH PULL-BAR (CABLE ASS'Y P/N:20453-0**T-#1)

& WITH INSULATION PULL-BAR (CABLE ASS'Y P/N:20453-0**T-#3) .

PULL-BAR (pull-tape※1) is assembled to HOUSING ASS'Y.

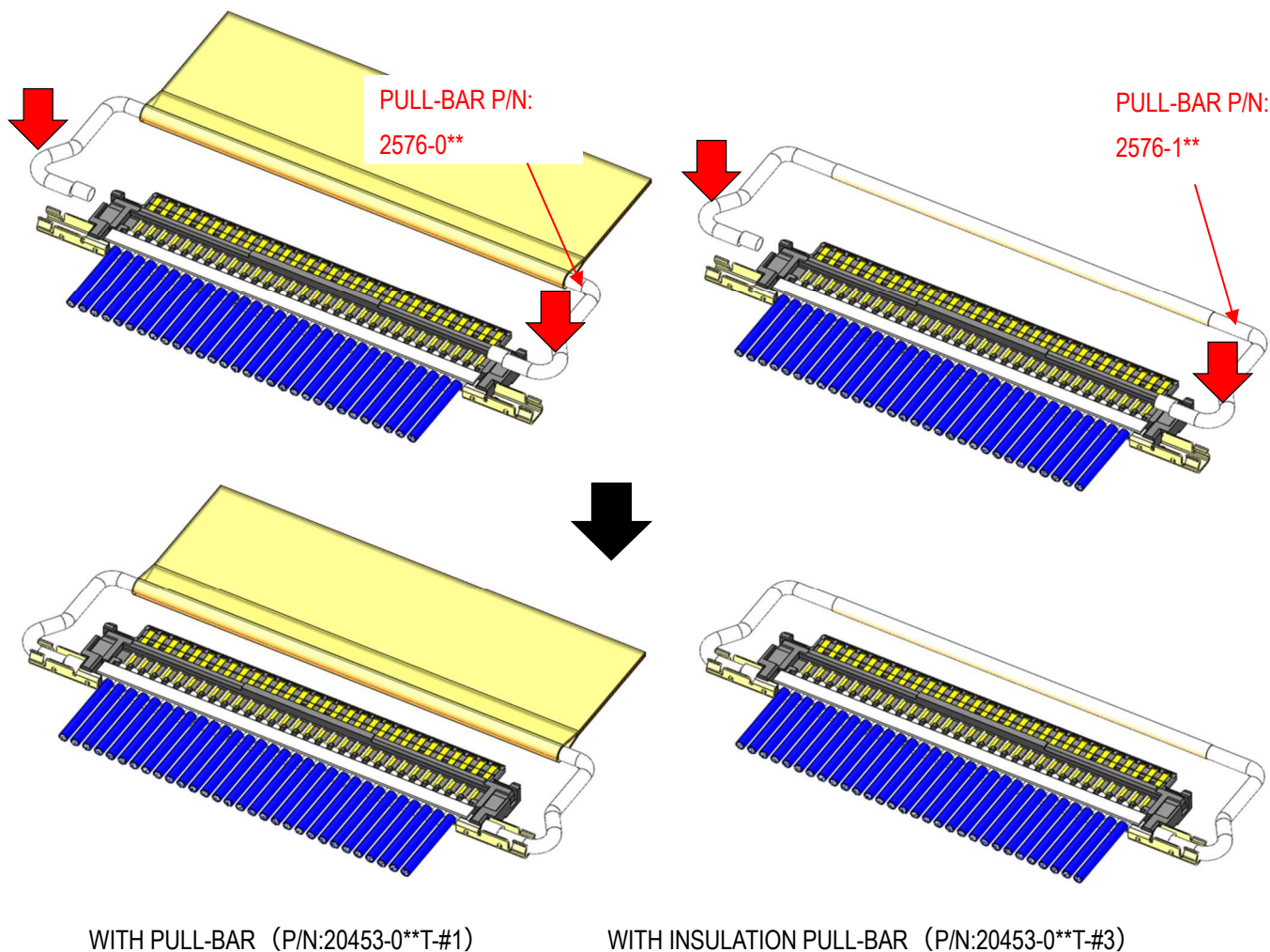

Fig.6-1 Assembly of PULL-BAR

※1 : ① In case of WITH PULL-BAR (CABLE ASS'Y P/N:20453-0**T-#1)

Pull-tape is necessary for insulating. Please make sure to attach it.

② In case of WITH INSULATION PULL-BAR (CABLE ASS'Y P/N:20453-0**T-#3)

Pull-tape is arbitrary.

Pull-tape thickness : 0.08mmMAX.

Recommended pull-tape

• TERAOKA's INSULATION TAPE

No.650S (#50) thickness=0.08mm

Positions	20P	30P	40P	50P
A	13.0	18.0	23.0	28.0
B	14.45	19.45	24.45	29.45

Unit:mm

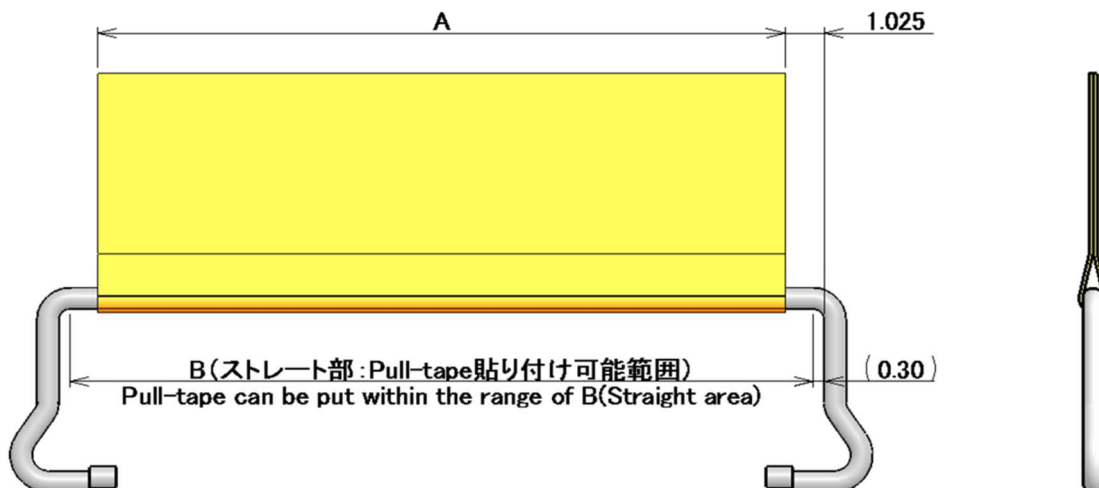

Caution1 : Pull-tape dimensions shall be based on recommended dimensions. Excessively small pull-tape may cause pull-bar deformation.

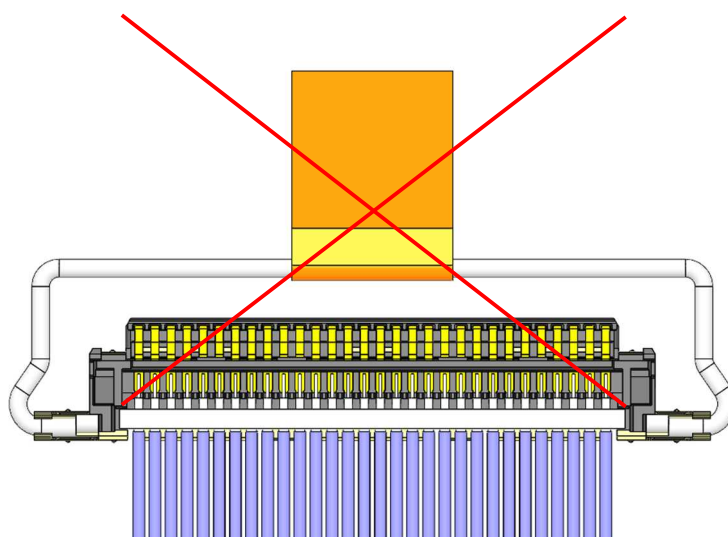

Fig.6-3 Pull-tape Caution of Pull-tape dimension

Caution 2 : Do not apply force toward arrowed directions. It may deform the pull-bar.

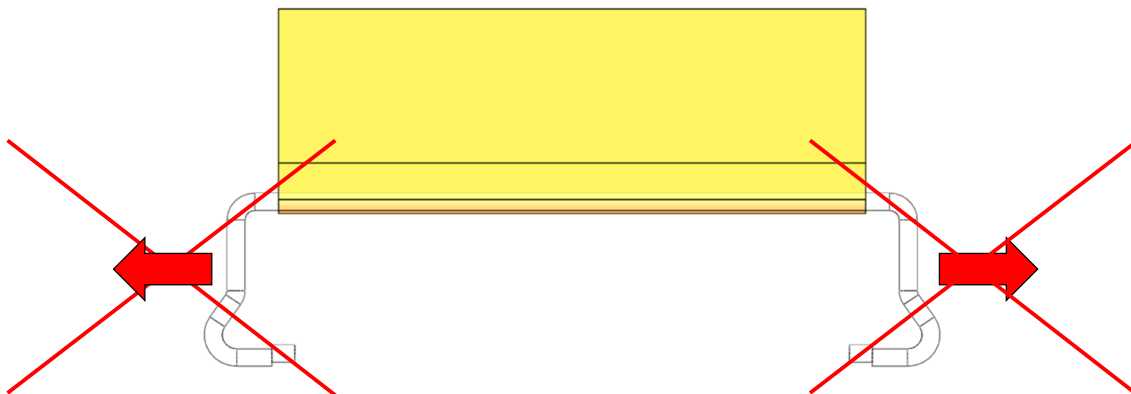

Fig.6-4 Caution of handling of pull-bar

Caution3 : Do not attach a pull-bar after shell-A is assembled. It may deform the pull-bar.

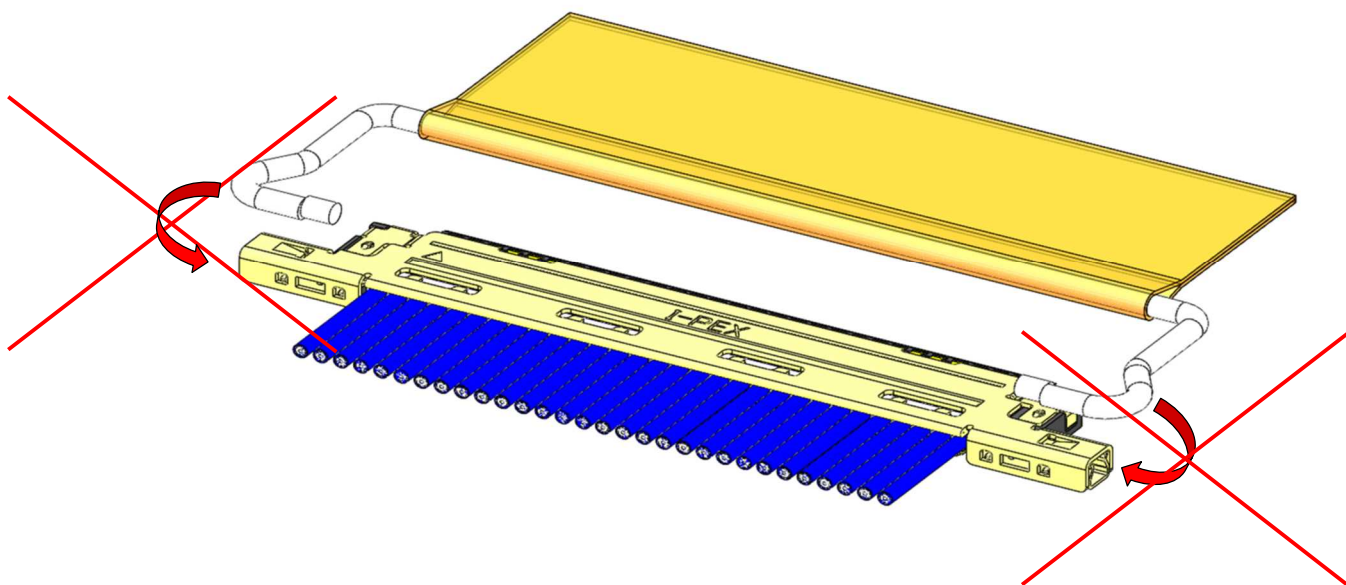

Fig.6-5 Caution of assembly of pull-bar

5-4. Assembly of SHELL-A

- ① Place the SHELL-A on the upper surface of the HOUSING ASS'Y and push only the blue shaded areas to assemble them.
Do not push the red shaded area by itself during assembling, or it may deform tip of the lock and may cause incomplete lock of the connector.

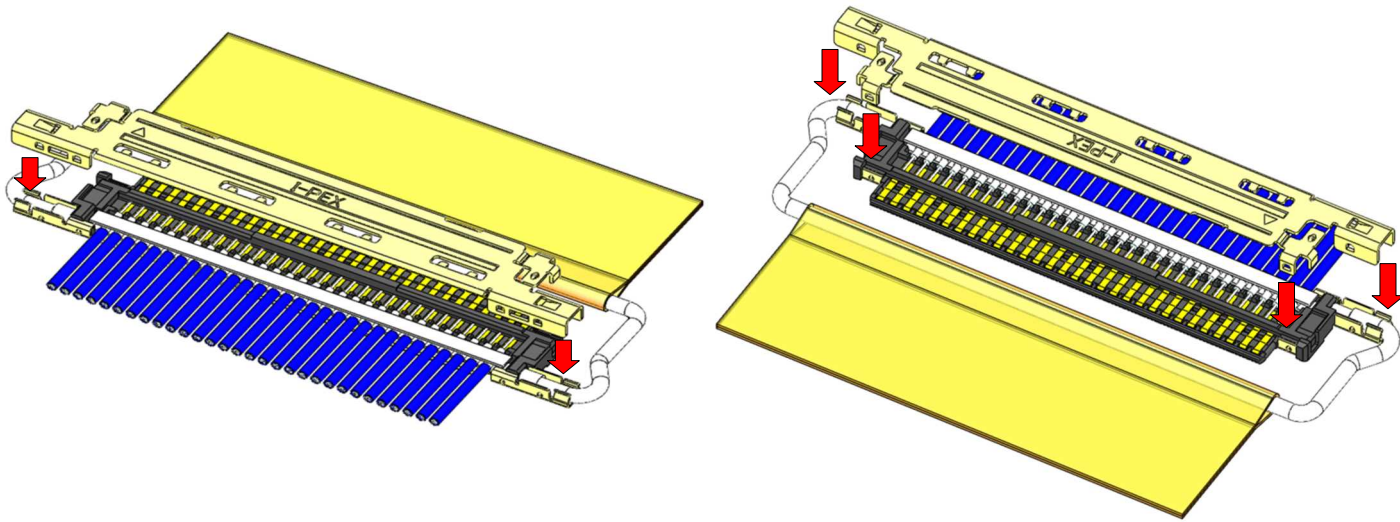

Fig.7-1 Assembly of SHELL-A

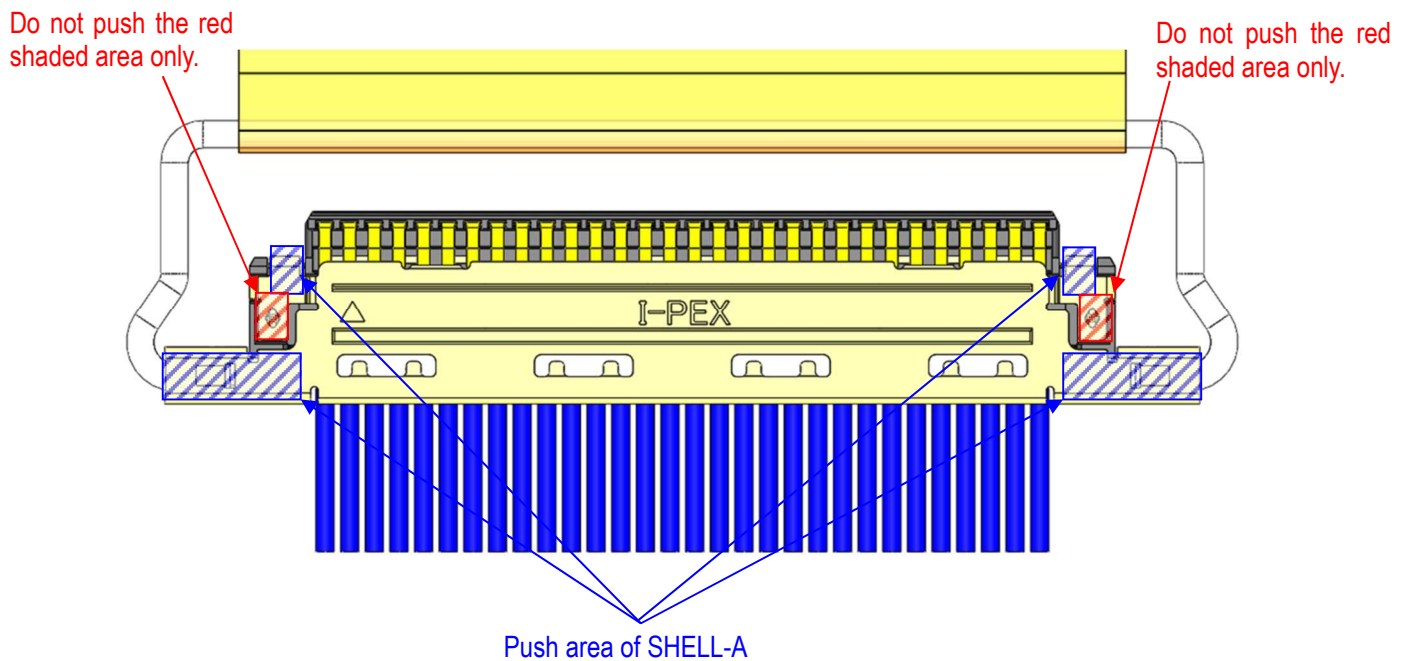

Fig.7-2 Push area of SHELL-A

- ② It confirms whether SHELL-A is being assembled normally.
Whether SHELL locks are being assembled normally. (Fig.8★ point)
Please refer to Fig.9 for shell-A lock criteria.

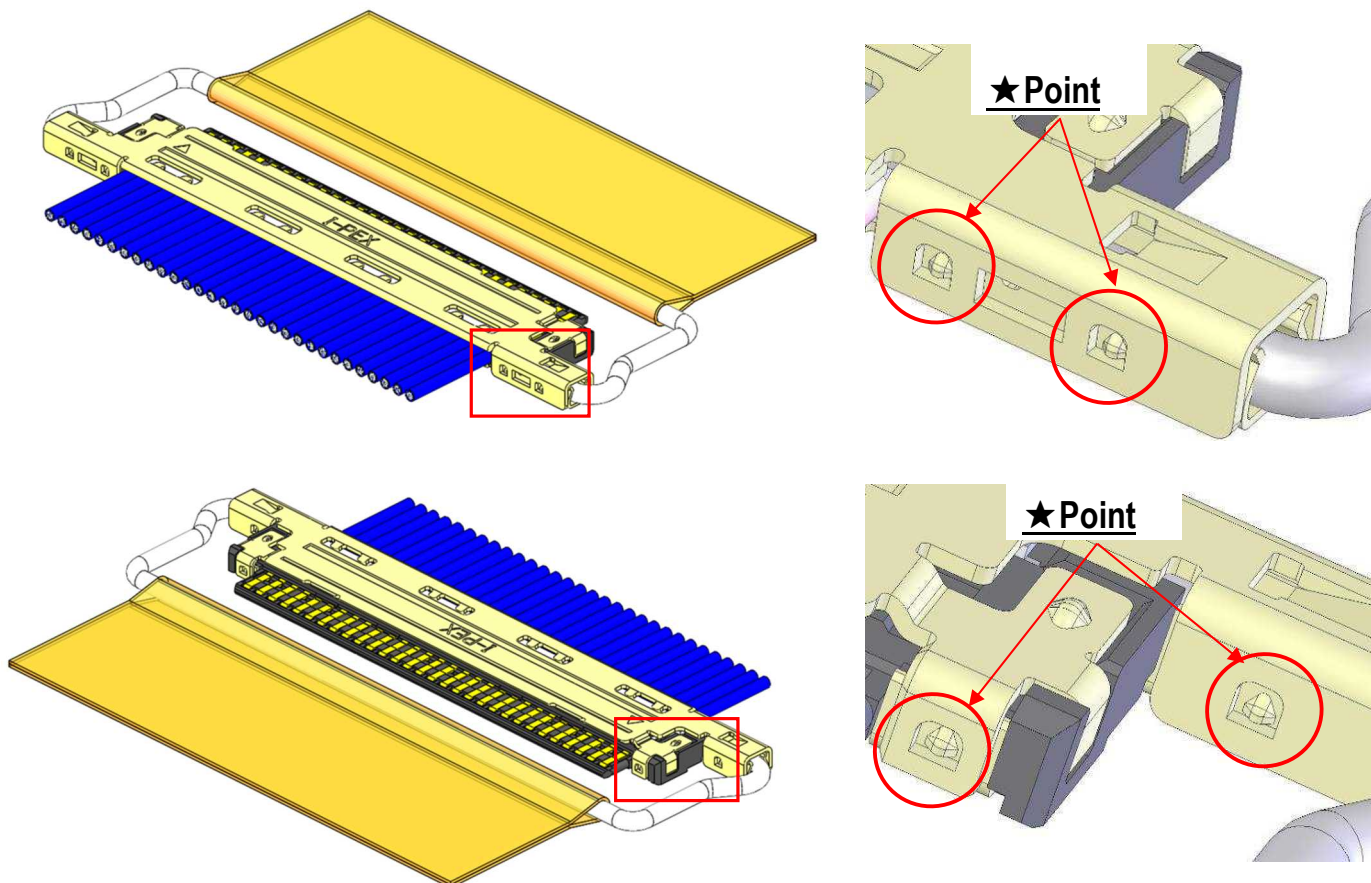

Fig.8 The assembly confirmation of SHELL-A

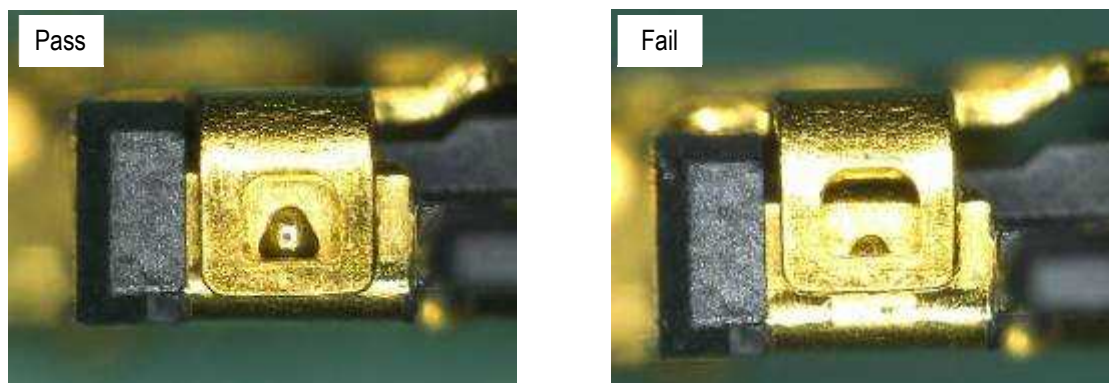

Fig.9 Shell-A lock criteria

Precaution:

Do not push shell-A toward bottom side as shown in Fig. 10 , or this may unlock shell-A.

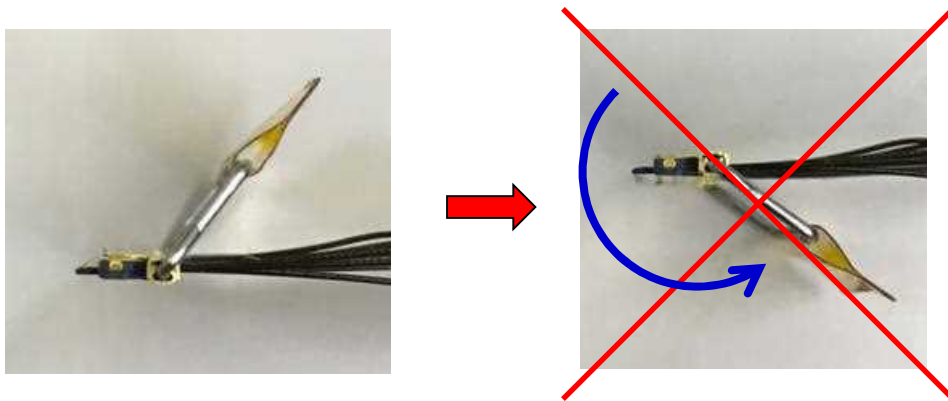

Fig.10 Improper handling of shell-A

- ③ Soldering SHELL-A ,B and GND BAR with the soldering iron at all designated points is recommended. (Fig.11,12 ◆ point)

Refer to Fig.15 for a limit of the solder height.

Conditions of Soldering iron refer to sheet 9.

※In case of soldering discrete cable, soldering at Fig.11,12 ◆point is impossible.

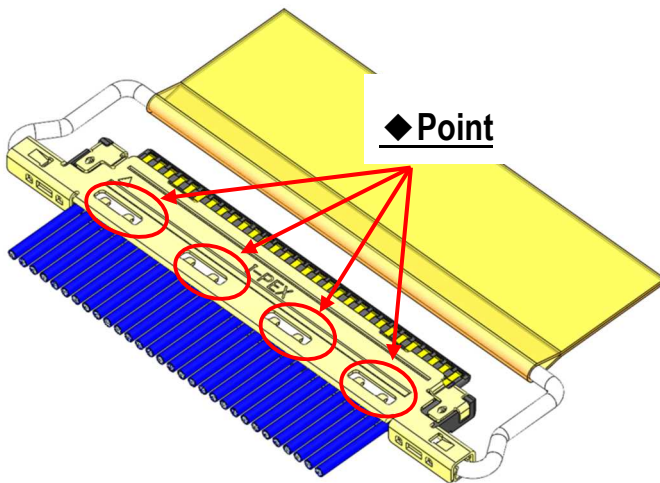

Fig.11 Soldering of SHELL-A and GND BAR

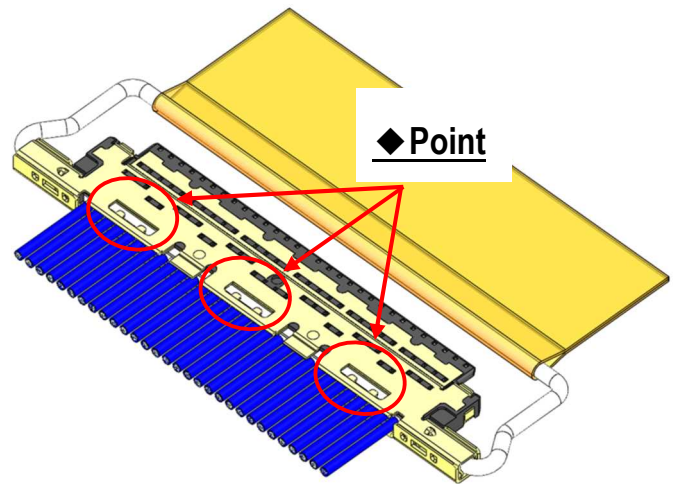

Fig.12 Soldering of SHELL-B and GND BAR

- ④ Soldering SHELL-A and SHELL-B with the soldering iron at all designated points is recommended. (Fig.13 ◆ point)

Conditions of Soldering iron refer to sheet 9.

※ In case of soldering discrete cable, soldering at Fig.13 ◆ point is necessary.

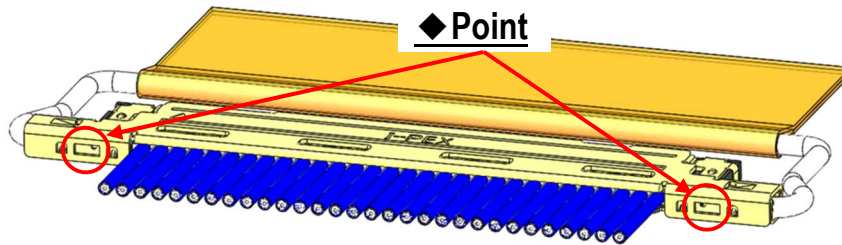

Fig.13 Soldering of SHELL-A and SHELL-B

Caution in soldering:

When using the pull-tape or the insulation pull-tape (P/N:2576-1**), please be careful the soldering iron does not touch to the pull-tape or the insulation coated area.

The heat of the soldering iron can melt them and there is possibility to cause short when mating with receptacle.

5-5. Cable fixation

Fix the cable terminal part with the bond.

Bond: LOCTITE 352

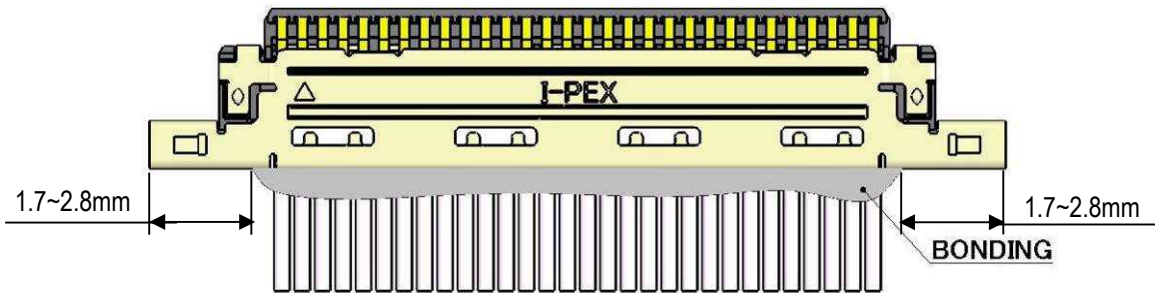

Fig.14 Bonding

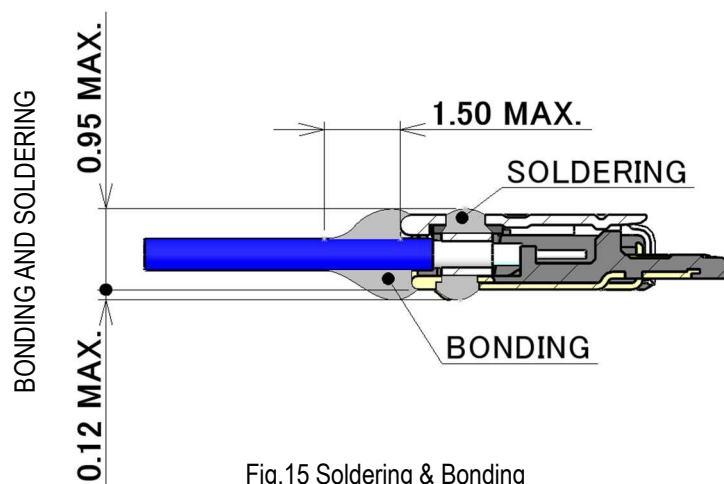

Fig.15 Soldering & Bonding