

CABLINE®-VS II PLUG

Part No. 20846 / 21070

Assembly Manual

4	S25062	January 31, 2025	K.Tanabe	M.Nakamura	T.Masunaga
3	S23273	September 26, 2023	H.Uchida	M.Nakamura	T.Masunaga
2	S22439	October 5, 2022	K.Baba	R.Takei	H.Ikari
1	S19446	July/22/'19	M.Nakamura	T.Masunaga	H.Ikari
Rev.	ECN	Date	Prepared by	Checked by	Approved by

1.Purpose :

This manual explains the soldering method and assembly processes of the CABLINE- VS II PLUG with lock bar assembly and shell-A.

2.Applicable Connector :

Name: CABLINE-VS II PLUG

Parts No.:

Set P/N	Cable Assembly	20846-0**T-01 / 21070-0**T-01
Discrete P/N	Housing Assembly	20847-0**T-01 / 21071-0**T-01
	Lock Bar Assembly	20848-0**T-01 / 21072-0**T-01
	Shell-A	3427-0**1 / 3859-0**1

3.Fixtures :

3.1 Components and Instruments Used in the Condition Confirmation

- Pulse Heater

Name	P/N	Manufacturer
Reflow Head	NA-66	Nippon Avionics Co., Ltd.
Pulse Heat Power Supply	TCW-215	Nippon Avionics Co., Ltd.

- Heater Tip

	20P	30P	40P
Thickness	0.5 ⁰ _{-0.05}	0.5 ⁰ _{-0.05}	0.5 ⁰ _{-0.05}
Width	10.0 ⁰ _{-0.03}	15.0 ⁰ _{-0.03}	20.0 ⁰ _{-0.03}

Unit: mm

- Recommended Solder Bar

Resin-free solder made by Uchihashi Estec Co., Ltd.

Positions		20P	30P	40P
Solder Size	AWG#32~#38	φ0.14	φ0.14	φ0.14
	AWG#40~#44	φ0.1	φ0.1	φ0.1
Length		10.0 mm Ref.	15.0 mm Ref.	20.0 mm Ref.

Unit: mm

4. Recommended Pulse Heat Condition

① Idle Temp.	150 °C
② 1 st Heat Temp.	220 °C
③ " Rise Time	0.5sec.
④ " Holding Time	3.0sec.
⑤ 2 nd Heat Temp.	300~320 °C
⑥ " Rise Time	0.5sec.
⑦ " Holding Time	3.0sec.
Heater Tip Pressure	5~10N

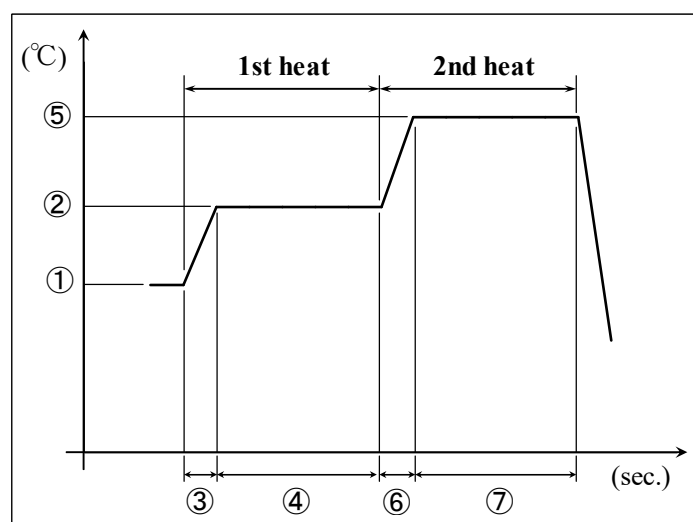

*This pulse heat condition was evaluated and confirmed by our pulse heat jig and instruments. The most optimum condition may change based on the shapes of pulse heat jig and instruments, the environments, or other reason.

Therefore, please examine the pulse heat condition adequately in advance of use.

5. Work Procedures :

5-1. Soldering of Center-Conductor

- ① The cables have to be fabricated as shown below in advance of soldering.

Pos.	B	G
20P	9.50	10.70
30P	14.50	15.70
40P	19.50	20.70

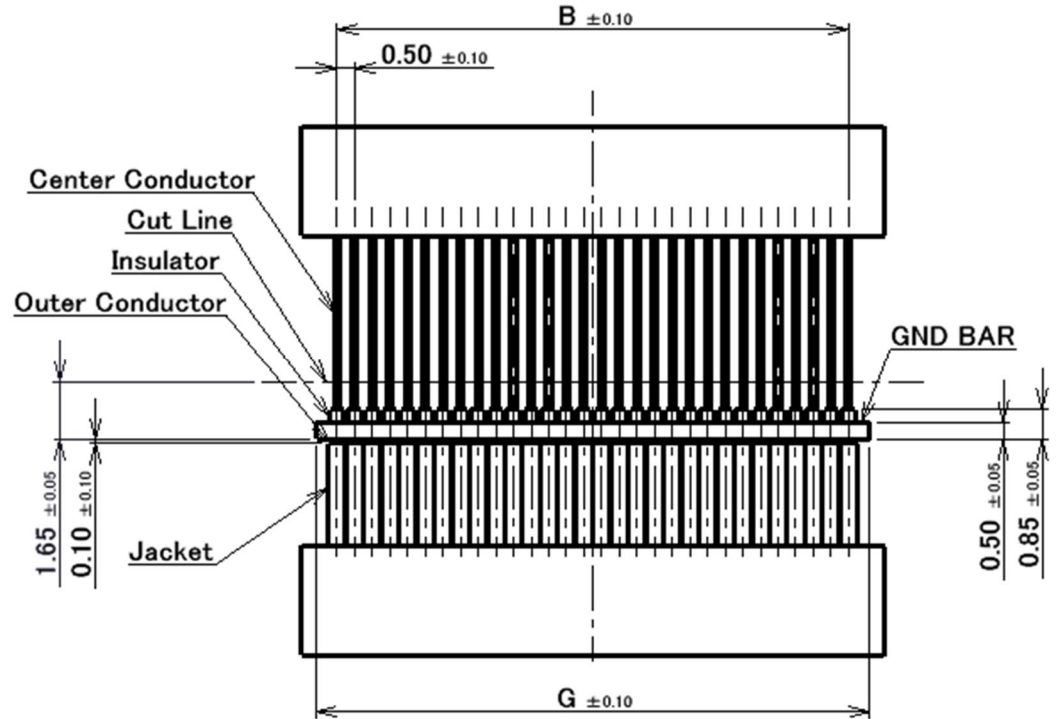

Recommended Micro-Coaxial Cable Dimensions

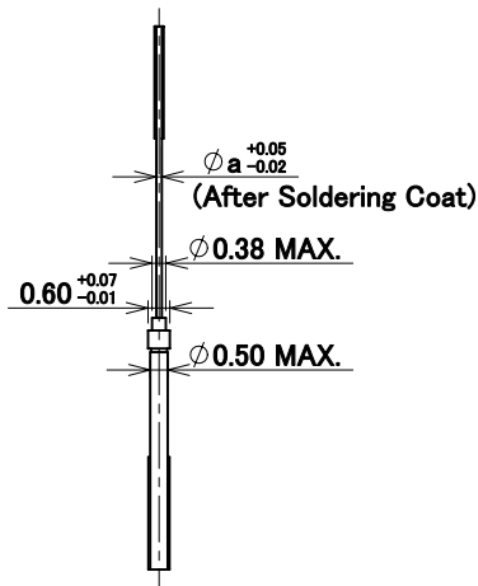

Micro-Coaxial Cable Dimensions

	a
#36	0.15
#38	0.12
#40	0.09
#42	0.075
#44	0.063

Micro-Coaxial Cable AWG#**

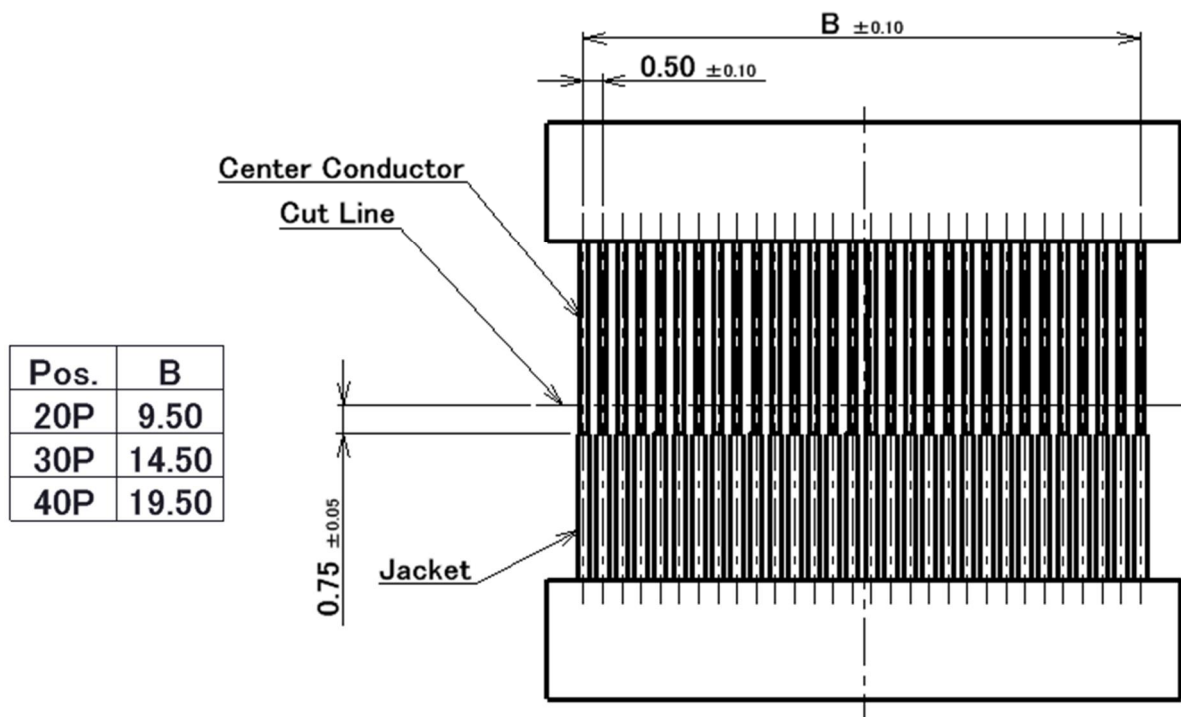

Pos.	B
20P	9.50
30P	14.50
40P	19.50

Recommended Discrete Wire Dimensions

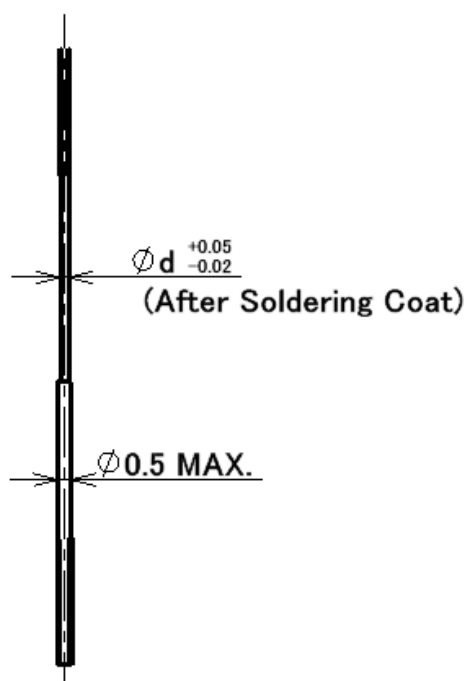

Discrete Wire Dimensions

	d	e
#32	0.24	0.41
#34	0.192	0.32
#36	0.15	0.25

Discrete Wire AWG#**

Pos.	B	G
20P	9.50	10.70
30P	14.50	15.70
40P	19.50	20.70

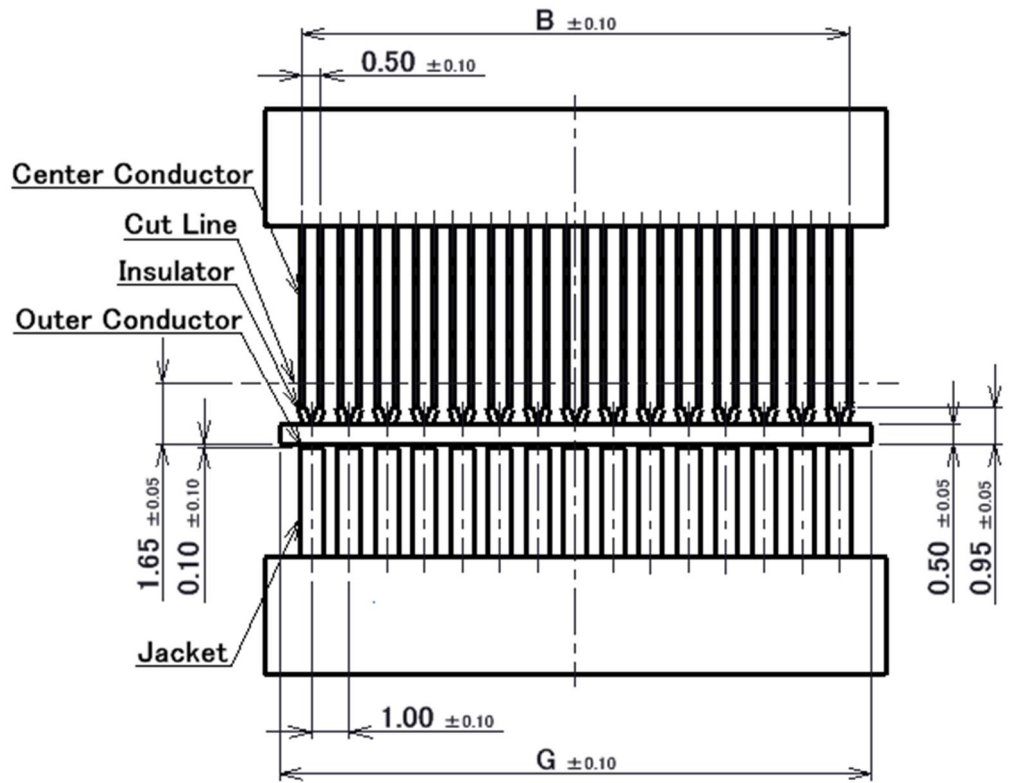

Recommended Twinax Cable Dimensions

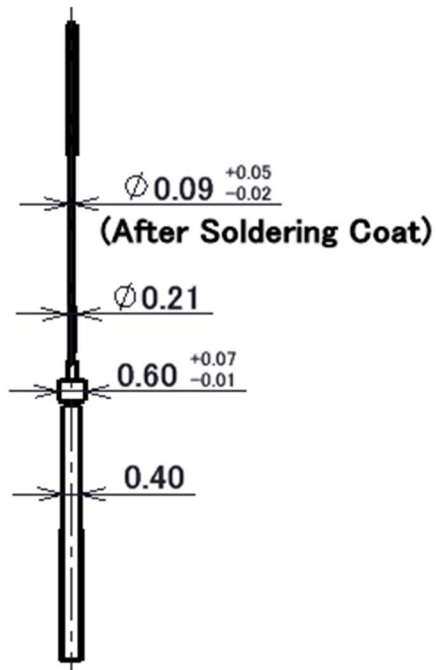

Twinax Cable AWG#40

② Apply flux to contacts using a dispenser or any other applicable tool and ensure that all contacts have been coated with flux.

Applying Flux Area

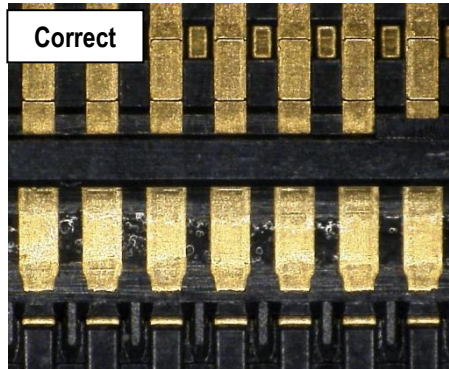
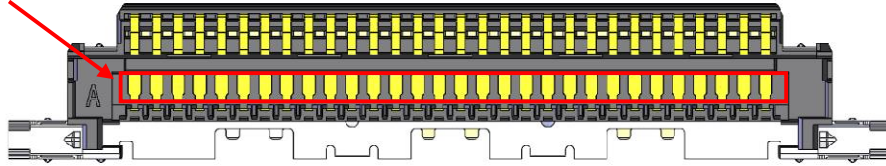

Photo.1 After Applying Flux

*Please do not apply flux too much like Photo.2. It can cause flux splash or leak to the mating area.

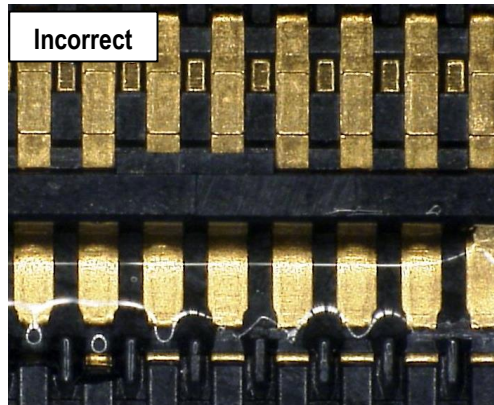

Photo.2 Extra Flux

*Do not use a cleaning machine or any other methods to clean the flux, or it may cause flux residue adhering to the mating parts.

③ Set the solder bar on the connector.

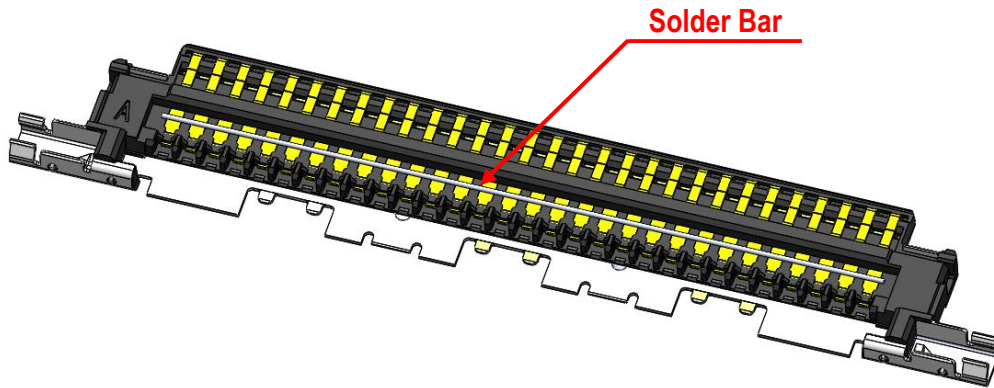

Fig.1 Set of Solder Bar

④ Set the cable or wire.

*To prevent potential contact between the core wire and the shell during discrete wire setting, ensure that a maximum of 0.2 mm is not exceeded, as illustrated in Figure 3.

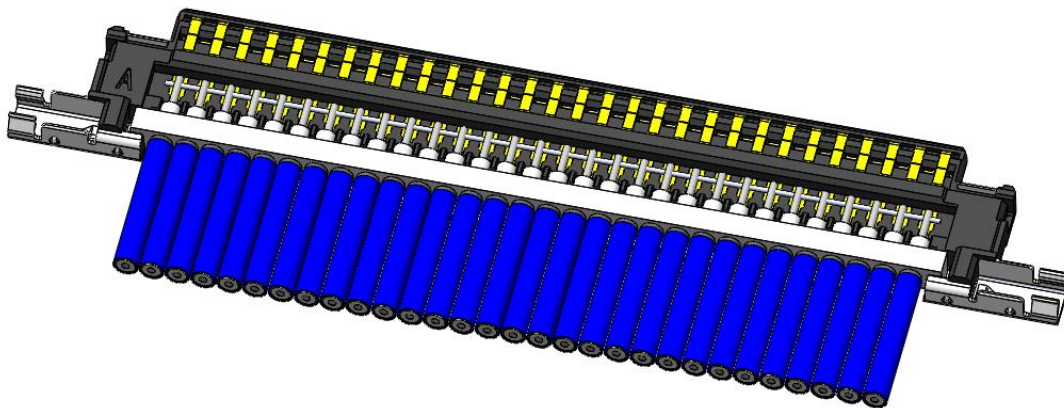

Fig.2 Set of Cable

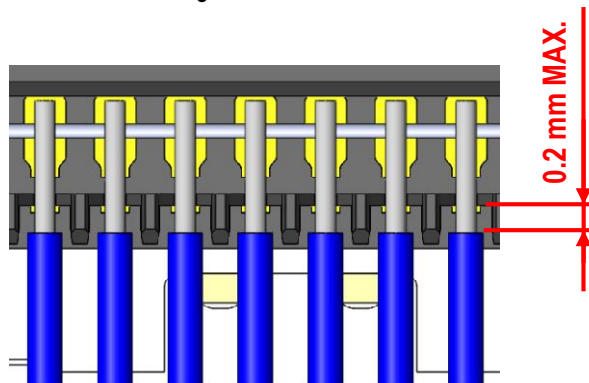

Fig.3 Setting Discrete Wire

⑤Center-conductors are soldered with pulse heater. See Photo.3 of soldering condition.



Photo.3 AWG#40

Caution: The shell bottom side of plug housing assembly has convex shape at the points shown in Fig.4, so please make escape shape on the receiving jig of the pulse heater to prevent interference.

	A	B
20P	-	15.30
30P	4.50	20.30
40P	9.00	25.40

Unit: mm

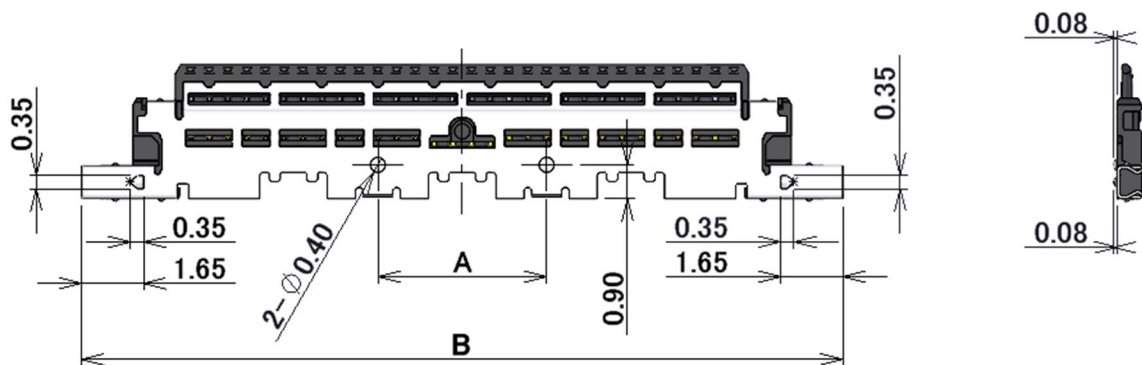

Fig.4 The Shell Bottom Side of Plug Housing Assembly

*When solder bridge is appeared between the terminal, try heating again with pulse heater only one time.

If the bridge isn't repaired, use the soldering iron only the failure point.

Condition of Soldering Iron : 50W

Operating Temperature : 350 °C

Application Time of Soldering Iron : Within 5sec.

*Because it might give product damage, please do not instigate a cable after soldering.

*When there might be the short circuit with shell-A, put an insulating tape in shell-A before assembly of shell-A.

Caution: Do not forcibly pull the cable toward red arrow direction after soldering or apply excessive load on the soldered area, or it may peel the solder. [Fig. 5]

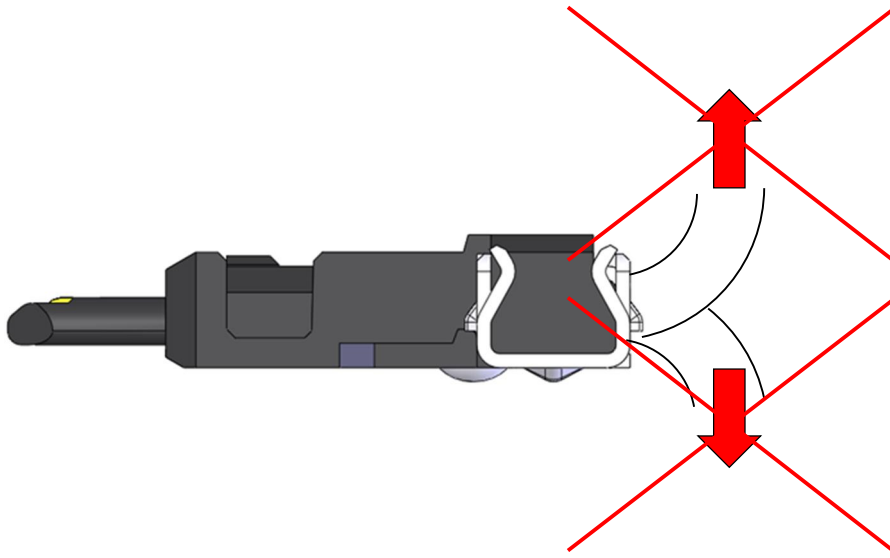
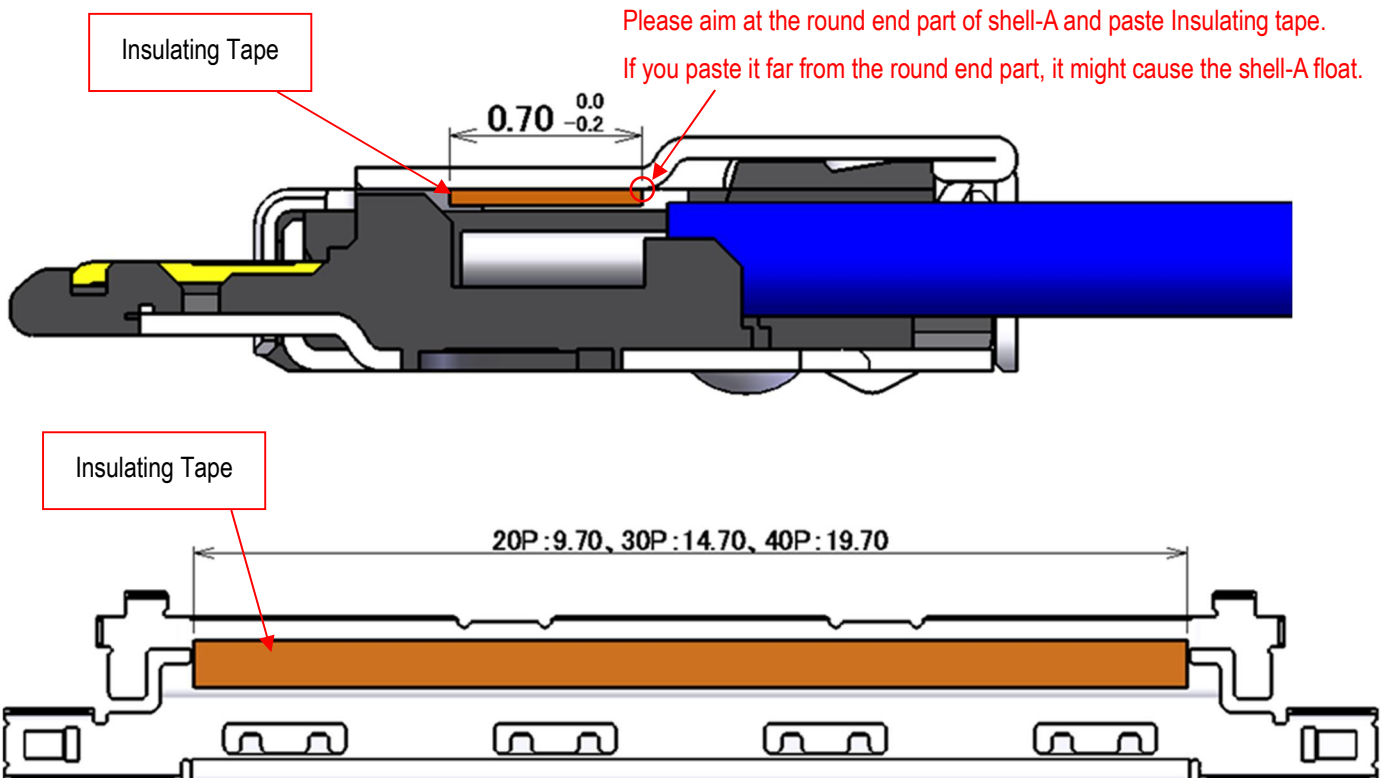

Fig.5 Cause of Solder Peeling

◆ Insulating Tape Thickness $t=0.06\text{mm}$



5-2. Cautions in treating shell-A

Shell-A is delivered in the reel with a carrier. The following is the method to cut shell-A from carrier.

- ① Cut carrier on the cut line of the left below picture (green line) by a scissors for metal.

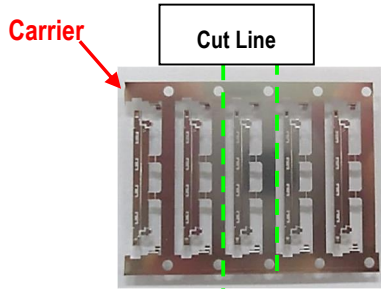

Photo.4 Before Cut

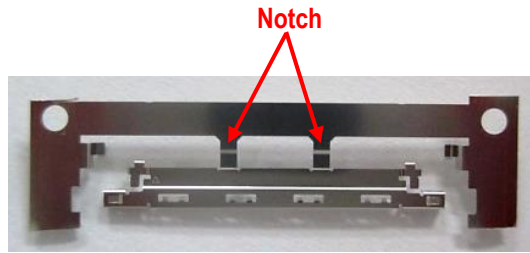

Photo.5 After Cut

- ② Hold the center of plug shell-A and cut it off from notch by ± 45 deg of reciprocating work.

When it does not be cut, try again this reciprocating work.

After separated, check there is no burr around the cut part. (Photo.7)

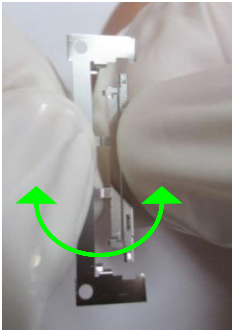

Photo.6 Cut Condition

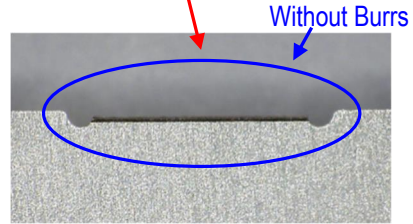
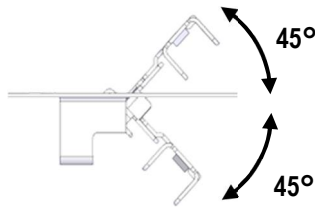

Photo.7 After Cut

Plug Shell-A Detail of Notch

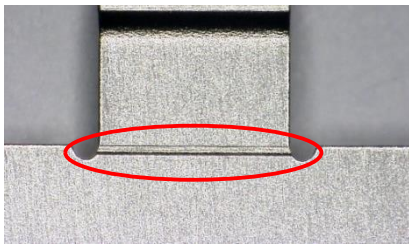

Photo.8 Bottom Side View

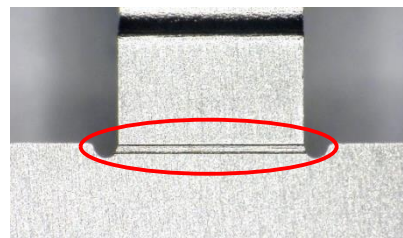

Photo.9 Upper Side View

Caution: By pulling like the photo below to cut off by force (red arrow direction), burrs and transformation can be caused.

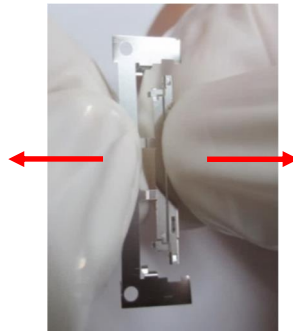

Photo.10 Cut by Force (Bad Example)

5-3. Assembly of Lock Bar Assembly

Lock bar assembly is assembled to housing assembly.

※I-PEX logo mark side of lock bar assembly facing the cable side.

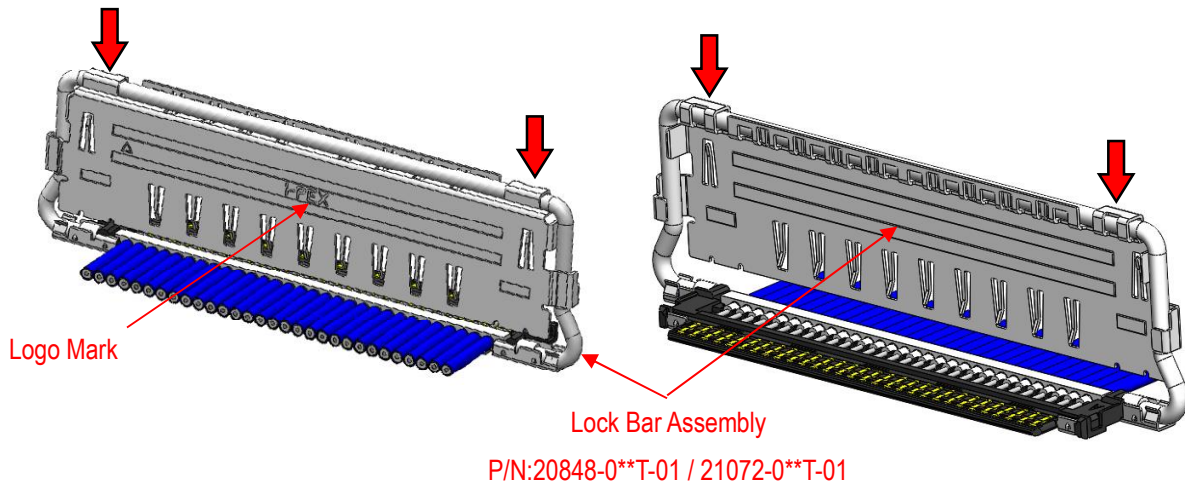

Fig.6 Assembly of Lock Bar Assembly

5-4. Assembly of Shell-A

① Lock bar assembly is tilted to the cable side 45 deg.

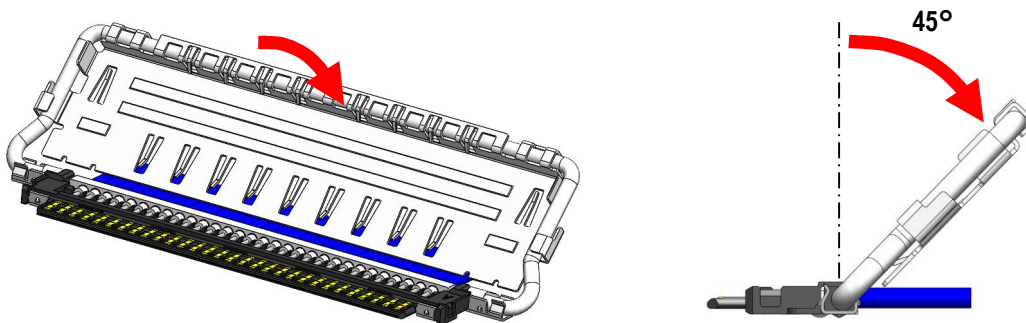

Fig.7 Tilt Lock Bar Assembly

② Shell-A is assembled from the upper side of housing assembly.

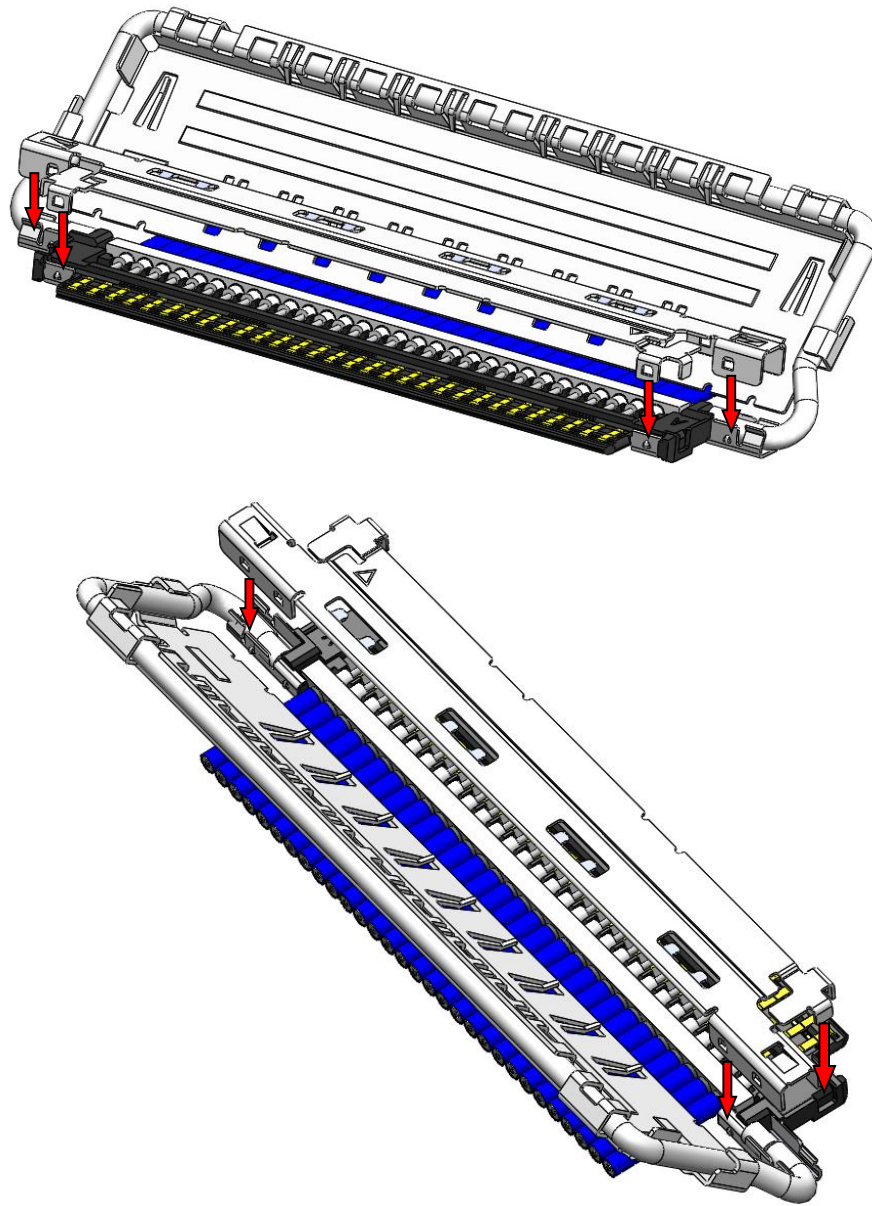

Fig.8 Assembly of Shell-A

③ Confirms whether shell-A is assembled properly.

Whether shell locks are assembled properly. (Fig.9★ Point)

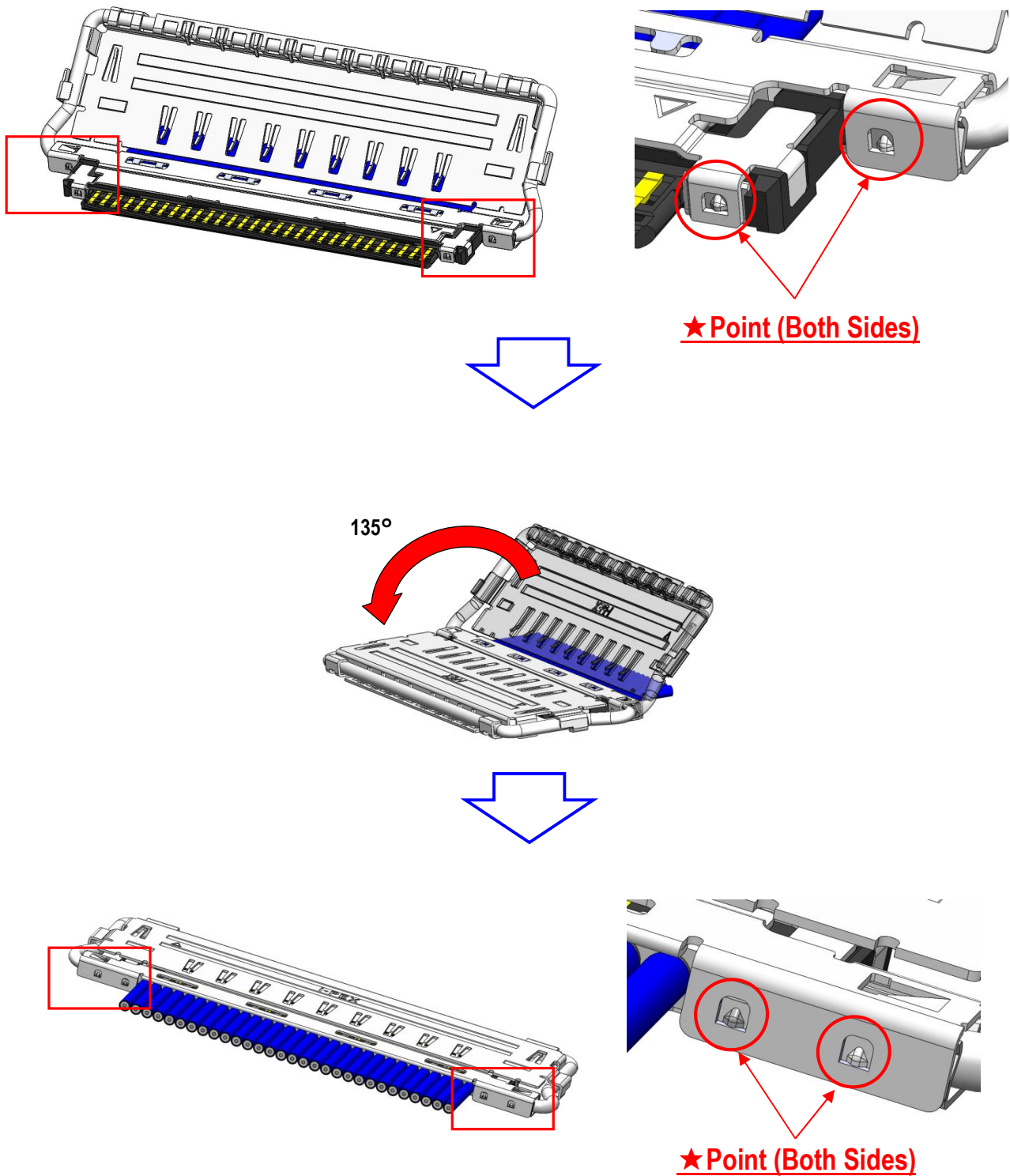

Fig.9 The Assembly Confirmation of Shell-A

④ Soldering shell-A, B and ground bar with the soldering iron at all designated points is recommended. (Fig.10,12 ◆Point)

Refer to Fig.16 for a limit of the solder height.

For conditions of soldering iron refer to sheet 8.

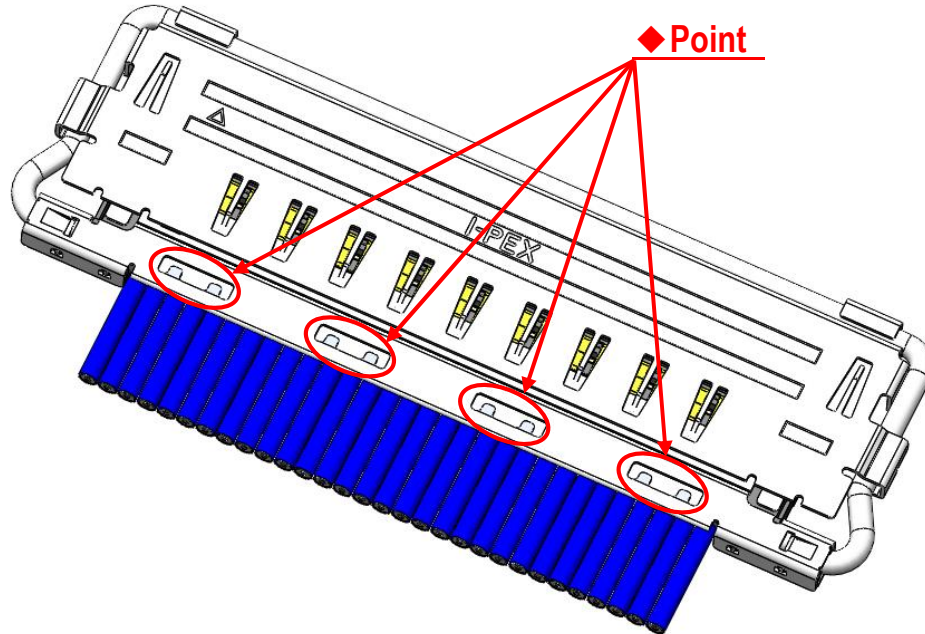

Fig.10 Soldering of Shell-A and Ground Bar

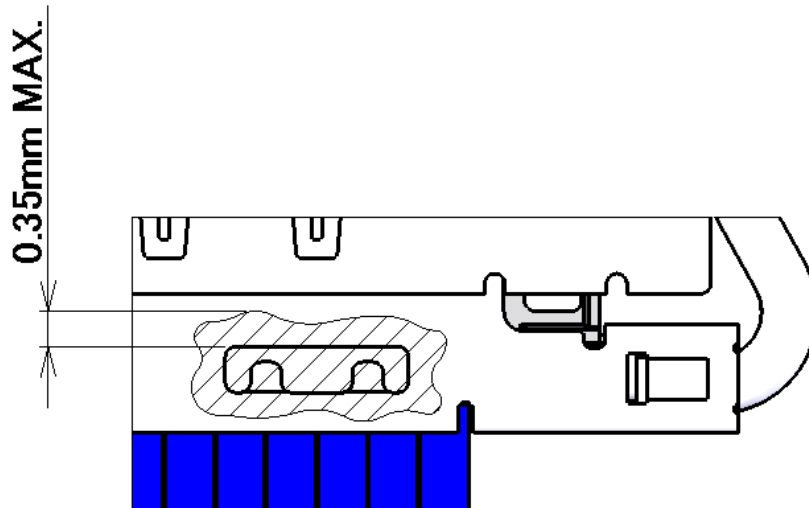

Fig.11 Solder Leaking

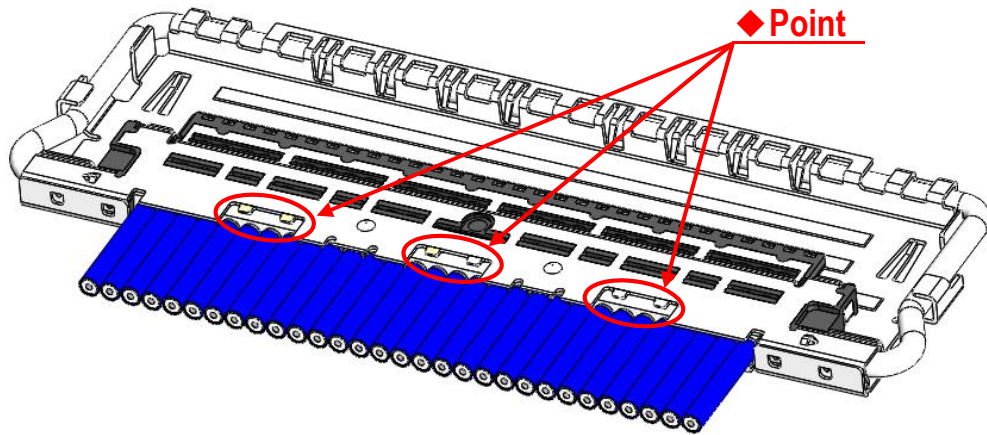

Fig.12 Soldering of Shell-B and Ground Bar

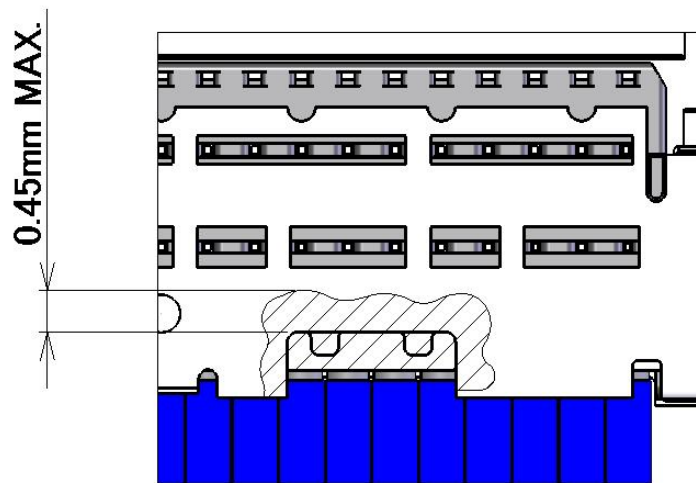

Fig.13 Solder Leaking

- ⑤ Soldering shell-A and shell-B with the soldering iron at all designated points is recommended. (Fig.14 ◆ Point)
Conditions of soldering iron refer to sheet 8.

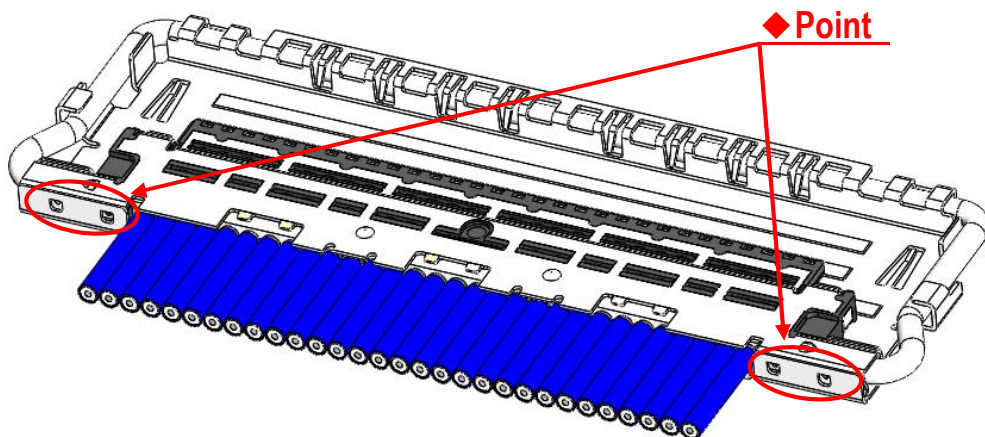

Fig.14 Soldering of Shell-A and Shell-B

5-5. Cable Fixation

Fix the cable terminal part with the bond.

Recommended Bond: LOCTITE 352

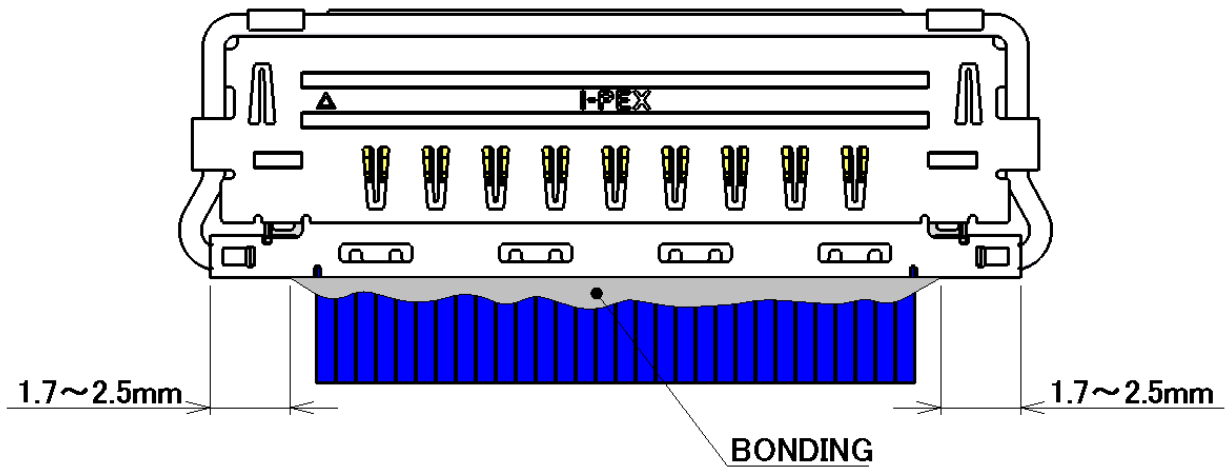

Fig.15 Bonding

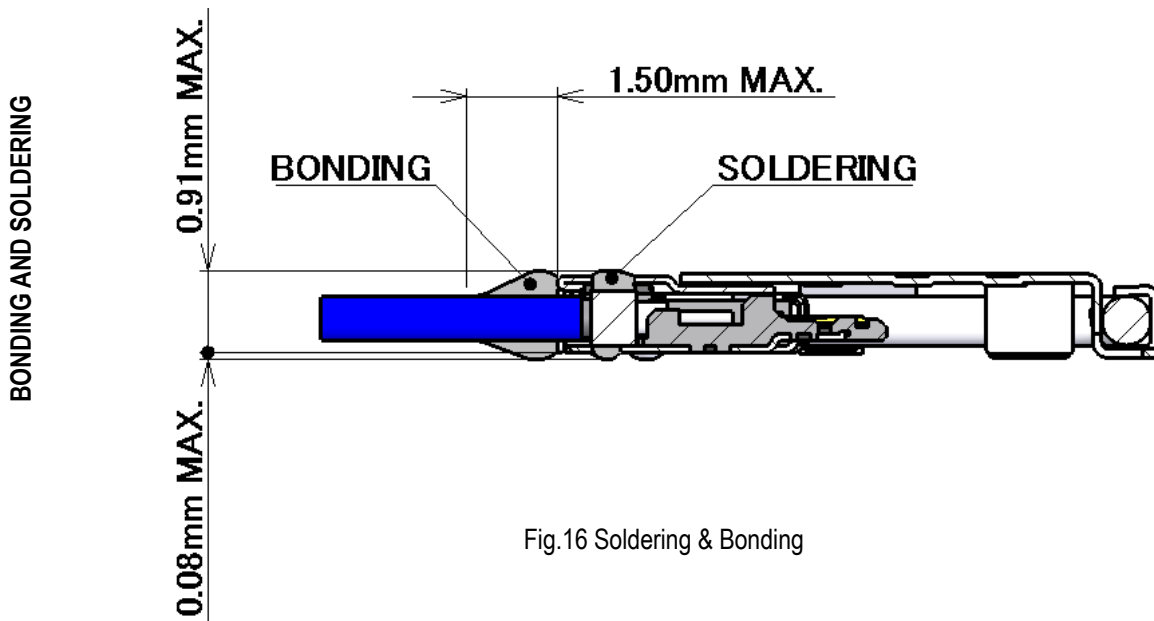

Fig.16 Soldering & Bonding