

# CABLINE®-UM PLUG

Part No. 20877 / 21074

## Assembly Manual

14	S25481	December 4, 2025	K.Tanabe	M.Nakamura	T.Masunaga
13	S25232	May 29, 2025	Y. Kawano		M. Takemoto
12	S25052	January 28, 2025	K.Tanabe	M.Nakamura	T.Masunaga
11	S24068	February 13, 2024	H.Uchida	M.Nakamura	T.Masunaga
Rev.	ECN	Date	Prepared by	Checked by	Approved by

## 1. Purpose :

This manual explains the soldering method and assembly processes of the CABLINE-UM PLUG with a lock cover, shell-A, and pull tape holder.

## 2. Applicable Connector :

Name: CABLINE-UM PLUG

Parts No. :

Set P/N	Cable Assembly	20877-##T-## / 21074-0**T-01
Discrete P/N	Housing Assembly	20878-##T-#1 / 21075-0**T-01
	Lock Cover	3493-##*1 / 3861-0**1
	Shell-A	3488-##*1 / 3860-0**1
	Pull Tape Holder	3588-##*1

## 3. Fixtures :

### 3-1. Components and Instruments Used in the Condition Confirmation

- Pulse Heater

Name	P/N	Manufacturer
Reflow Head	NA-66	Nippon Avionics Co., Ltd
Pulse Heat Power Supply	TCW-215	Nippon Avionics Co., Ltd

- Heater Tip

Positions	30P	40P	50P	60P	70P
Thickness	0.5 <sup>0</sup> <sub>-0.05</sub>	0.5 <sup>0</sup> <sub>-0.05</sub>	0.5 <sup>0</sup> <sub>-0.05</sub>	0.5 <sup>0</sup> <sub>-0.05</sub>	0.5 <sup>0</sup> <sub>-0.05</sub>
Width	12.2 <sup>0</sup> <sub>-0.03</sub>	16.2 <sup>0</sup> <sub>-0.03</sub>	20.2 <sup>0</sup> <sub>-0.03</sub>	24.2 <sup>0</sup> <sub>-0.03</sub>	28.2 <sup>0</sup> <sub>-0.03</sub>

Unit: mm

- Recommended Solder Bar

Resin-free solder made by Uchihashi Estec Co., Ltd.

Positions		30P	40P	50P	60P	70P
Solder Size	AWG#34~#38	φ0.14	φ0.14	φ0.14	φ0.14	φ0.14
	AWG#40~#44	φ0.1	φ0.1	φ0.1	φ0.1	φ0.1
Length		12.0 mm Ref.	16.0 mm Ref.	20.0 mm Ref.	24.0 mm Ref.	28.0 mm Ref.

Unit: mm

## 4. Recommended Pulse Heat Condition

① Idle Temp.	150 °C
② 1 <sup>st</sup> Heat Temp.	220 °C
③ " Rise Time	0.5sec.
④ " Holding Time	3.0sec.
⑤ 2 <sup>nd</sup> Heat Temp.	300~320 °C
⑥ " Rise Time	0.5sec.
⑦ " Holding Time	3.0sec.
Heater Tip Pressure	5~10N

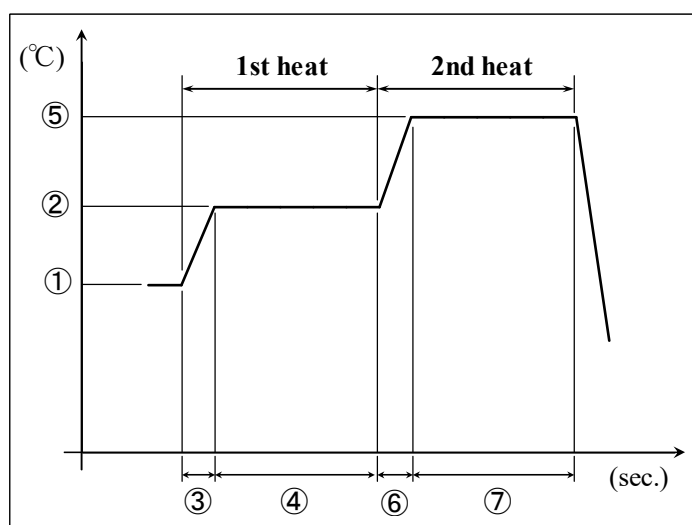

\*This pulse heat condition was evaluated and confirmed by our pulse heat jig and instruments.

The most optimum condition may change based on the shapes of pulse heat jig and instruments, the environments, or other reason.

Therefore, please examine the pulse heat condition adequately in advance of use.

## 5. Work Procedures :

### 5-1. Soldering of Center-Conductor

- ① The cables have to be fabricated as shown below in advance of soldering.

Pos.	D
30	11.60
40	15.60
50	19.60
60	23.60
70	27.60

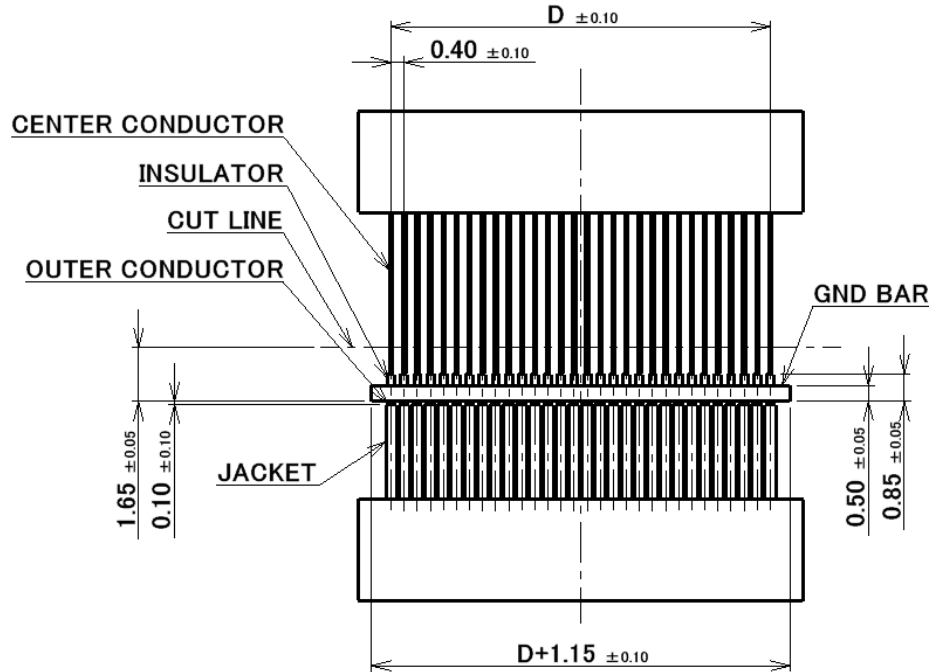

Recommended Micro-Coaxial Cable Dimensions

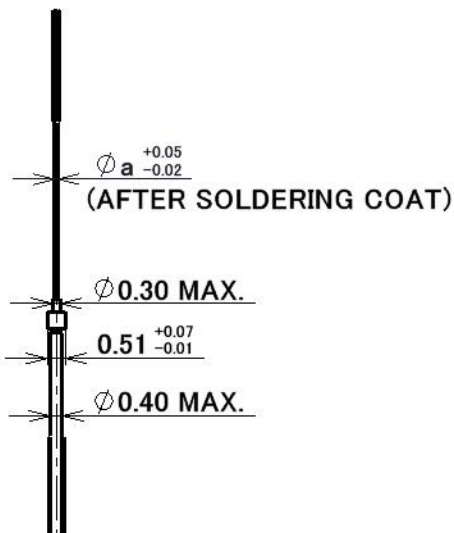

Micro-Coaxial Cable AWG#\*\*

### Characteristic Impedance Matching Micro-Coaxial Cable

	a
#38	0.12
#40	0.09
#42	0.075
#44	0.063

### Characteristic Impedance Un-Matching Micro-Coaxial Cable

	a
#36	0.15

Micro-Coaxial Cable #36: Not Recommended for  
High Speed Signal Transfer

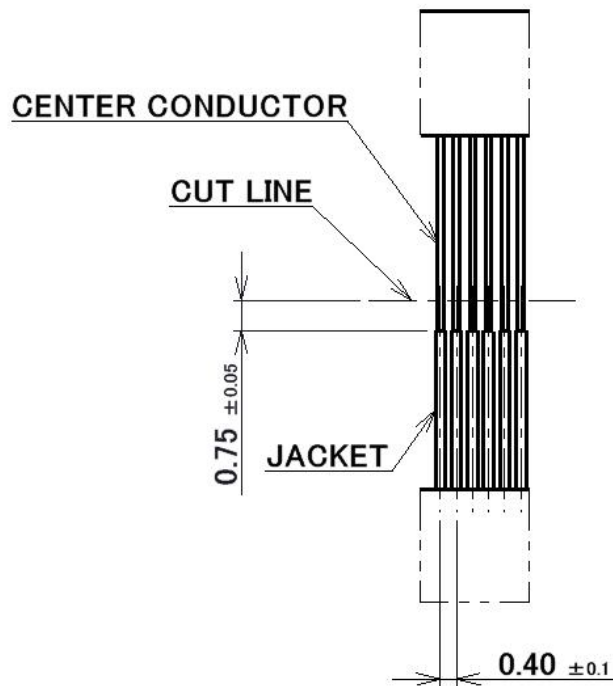

Recommended Discrete Wire Dimensions

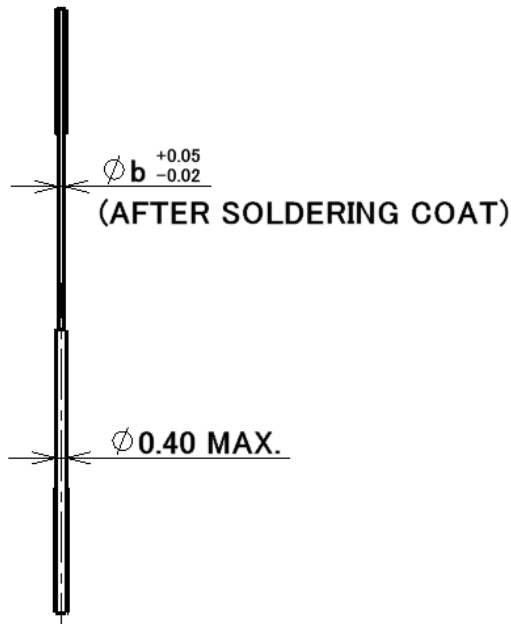

Discrete Wire Dimensions

	b
#34	0.192
#36	0.15

Discrete Wire AWG#\*\*

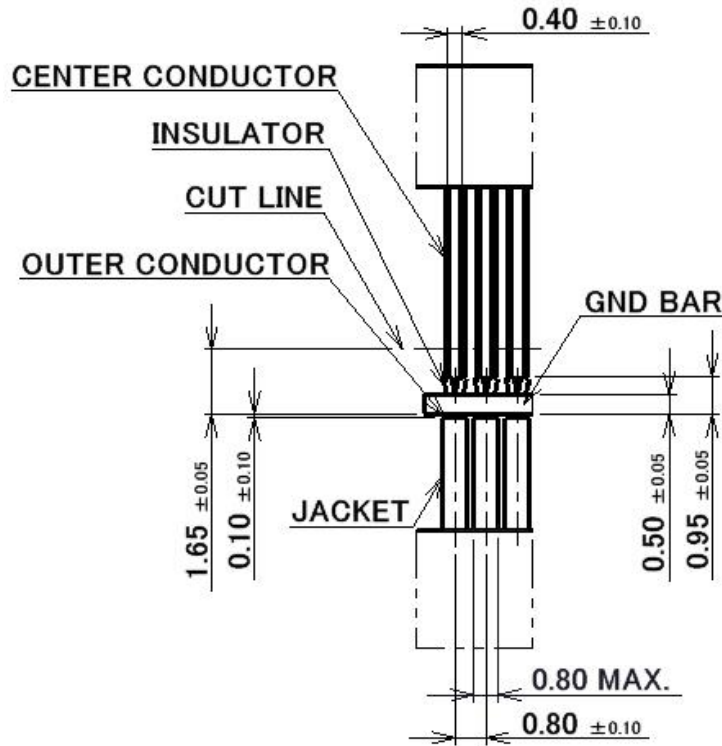

Recommended Twinaxial Cable Dimensions

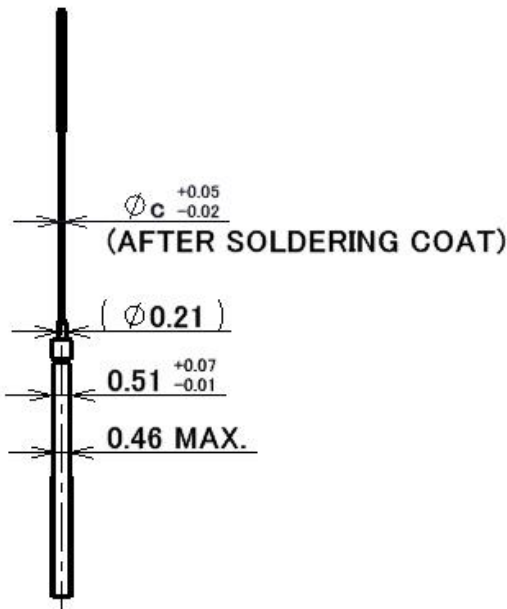

Twinaxial Cable Dimensions

	c
#40	0.09
#42	0.075

Twinaxial Cable AWG#\*\*

② Apply flux to contacts using a dispenser or any other applicable tool and ensure that all contacts have been coated with flux.

**Applying Flux Area**

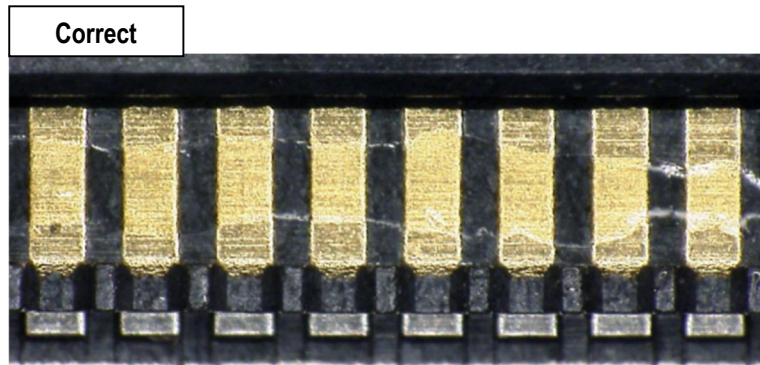
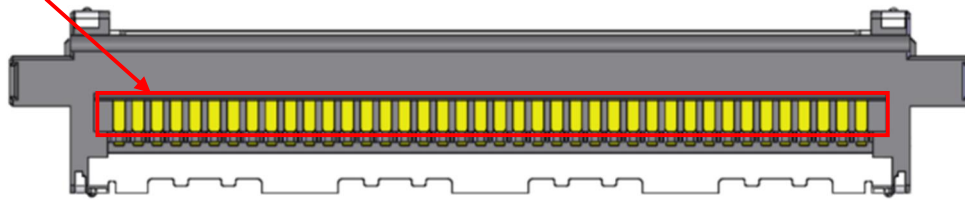

Photo.1 After Applying Flux

\*Please do not apply flux too much like Photo.2. It can cause flux splash or leak to the mating area.

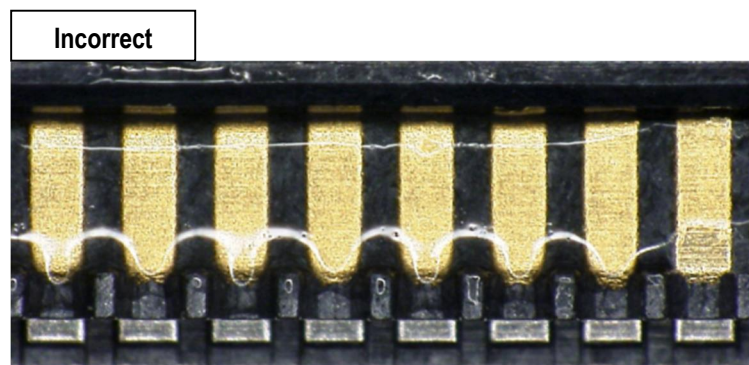

Photo.2 Extra Flux

\*Do not use a cleaning machine or any other methods to clean the flux, or it may cause flux residue adhering to the mating parts.

③ Set the solder bar on the connector.

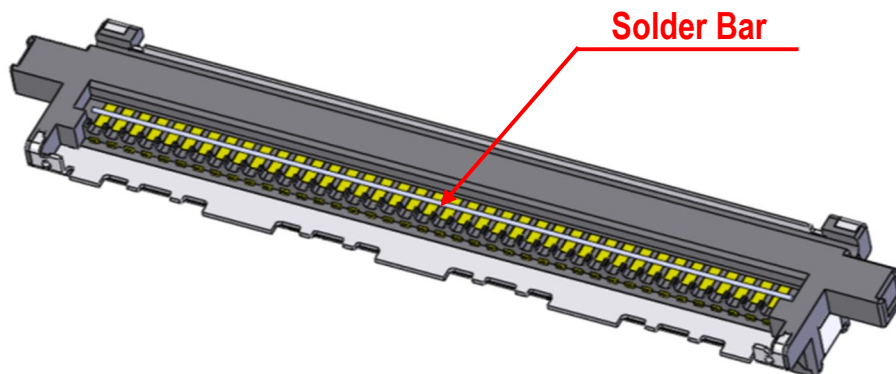

Fig.1 Set of Solder Bar

④ Set the cable or wire.

\* To prevent potential contact between the core wire and the shell during discrete wire setting, ensure that a maximum of 0.2 mm is not exceeded, as illustrated in Figure 3.

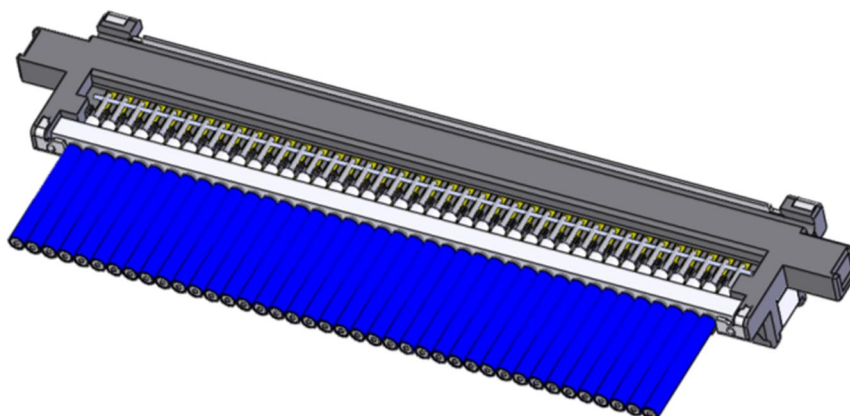

Fig.2 Set of Cable

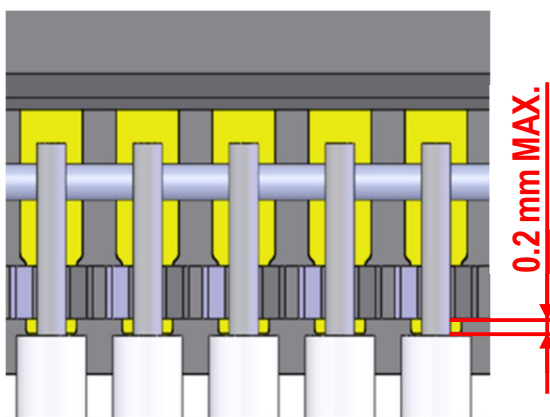

Fig.3 Setting Discrete Wire

⑤ Center-conductors are soldered with pulse heater. See Photo.3 of soldering condition.

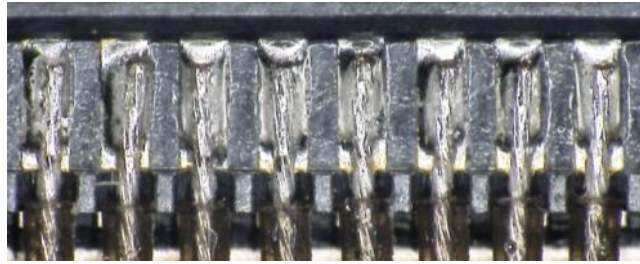

Photo.3 AWG#40

\*When solder bridge is appeared between the terminal, try heating again with pulse heater only one time.

If the bridge isn't repaired, use the soldering iron only the failure point.

Condition of Soldering Iron : 50W

Operating Temperature : 350 °C

Application Time of Soldering Iron : Within 5sec.

\*Do not agitate the cable after soldering the core wire, as this may damage the product.

## 5-2. Cautions in Treating Lock Cover

Lock cover is delivered in the reel with a carrier.  
The following is the method to cut lock cover from carrier.

- ① Cut carrier on the cut line of the left below picture (green line) by a scissors for metal.

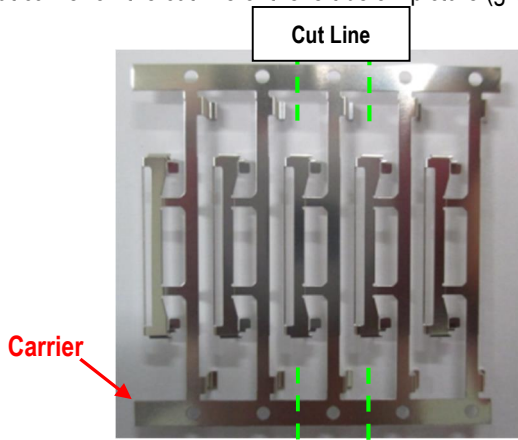

Photo.4 Before Cut



Photo.5 After Cut

- ② Hold the center of lock cover and cut it off from notch by  $\pm 45$  deg of reciprocating work. When it does not be cut, try again this reciprocating work. After separated, check there is no burr around the cut part. (Photo.7)

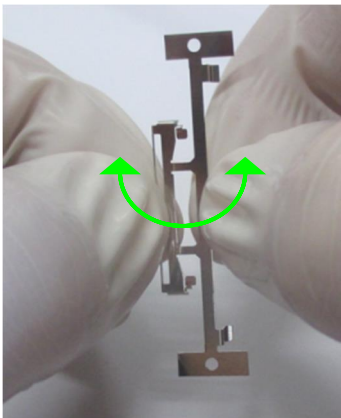

Photo.6 Cut Condition

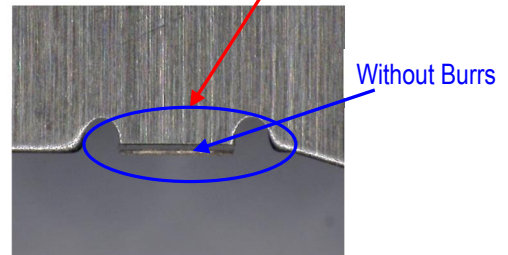
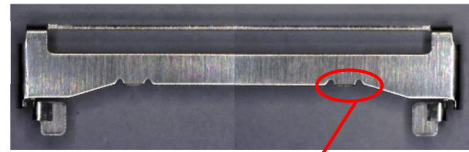
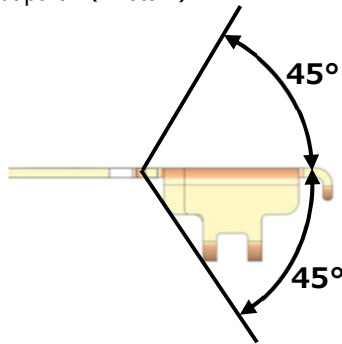

Photo.7 After Cut

Lock Cover Detail of Notch

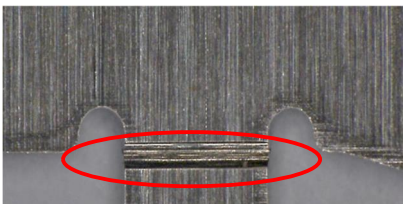

Photo.8 Bottom Side View

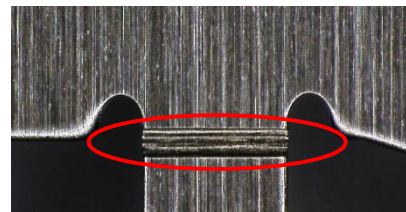

Photo.9 Upper Side View

Caution: By pulling like the photo below to cut off by force (red arrow direction), burrs and deformation can be caused.

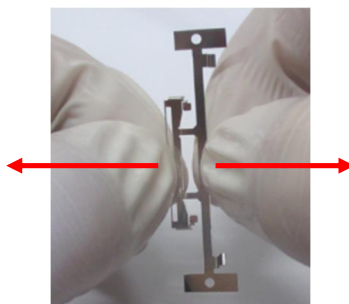

Photo.10 Cut by Force (Bad Example)

### 5-3. Assembly of Lock Cover

Lock cover is assembled from upper side of housing assembly.

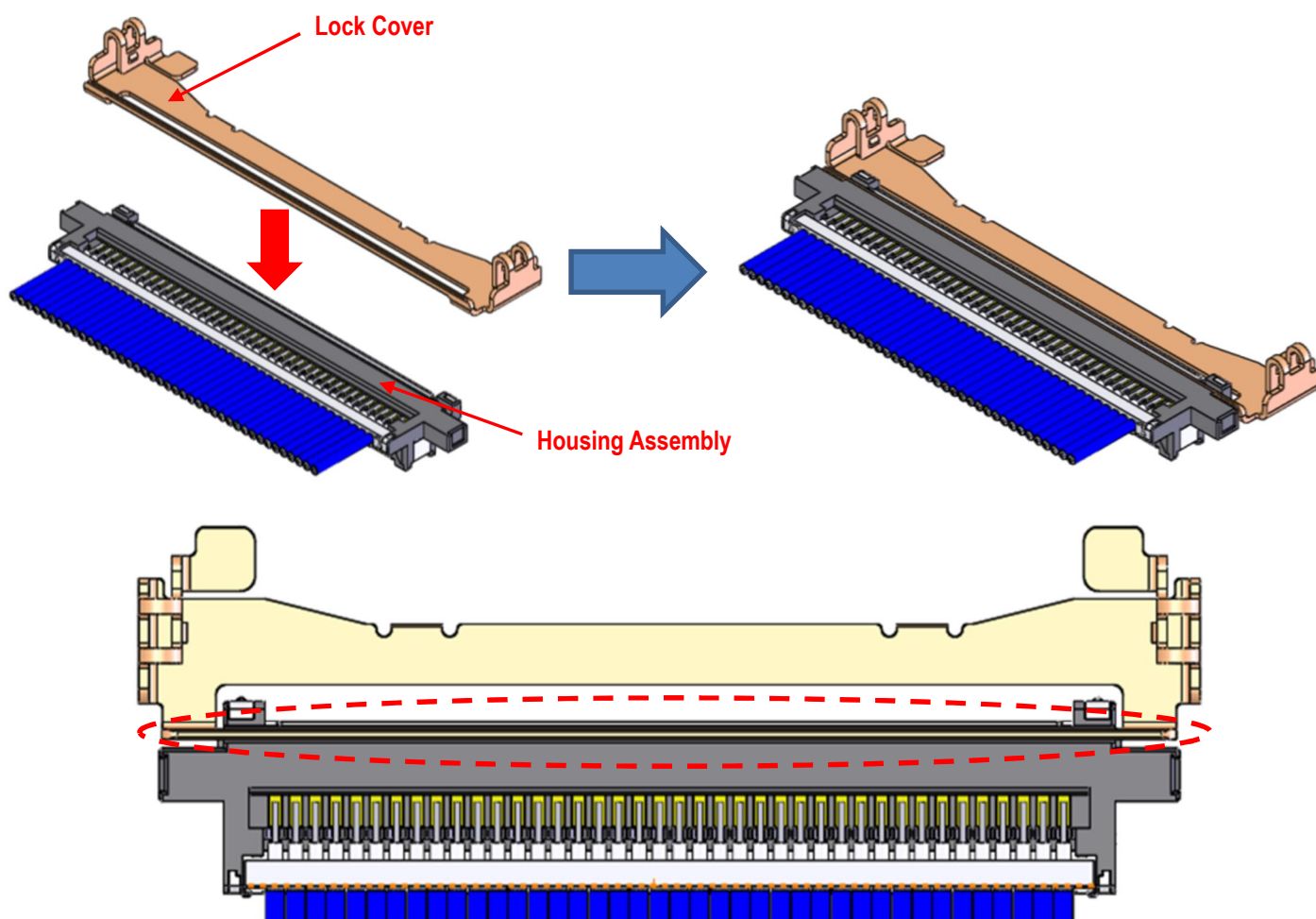

Fig.4 Assembly of Lock Cover

## 5-4. Cautions in Treating Shell-A

Shell-A is delivered in the reel with a carrier. The following is the method to cut shell-A from carrier.

- ① Cut carrier on the cut line of the left below picture (green line) by a scissors for metal.

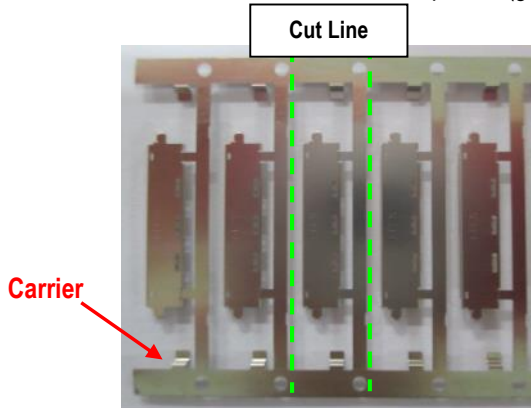

Photo.11 Before Cut

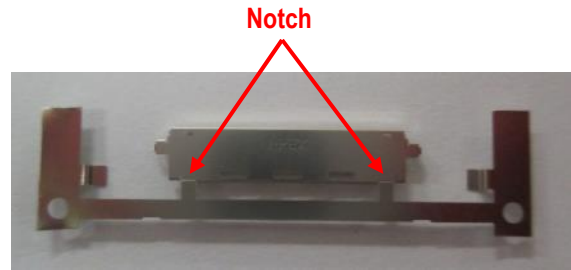

Photo.12 After Cut

- ② Hold the center of shell-A and cut it off from notch by  $\pm 45$  deg of reciprocating work. When it does not be cut, try again this reciprocating work. After separated, check there is no burr around the cut part. (Photo.14)

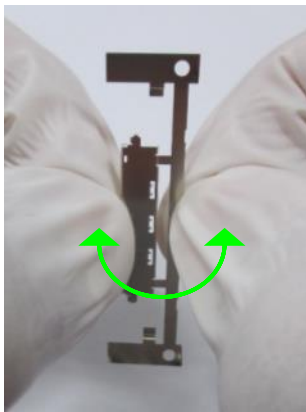

Photo.13 Cut Condition

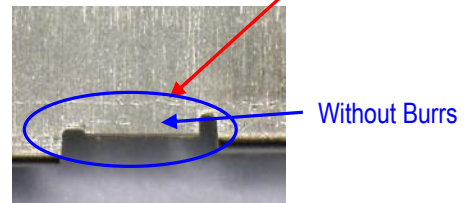
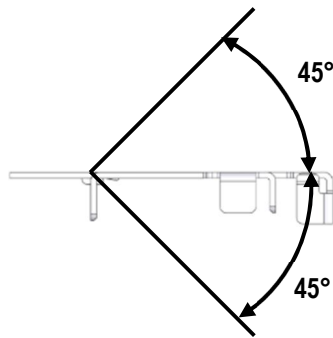

Photo.14 After Cut

### Plug Shell-A Detail of Notch

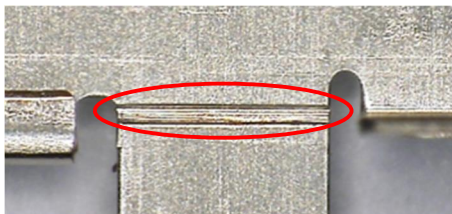

Photo.15 Bottom Side View



Photo.16 Upper Side View

Caution: By pulling like the photo below to cut off by force (red arrow direction), burrs and transformation can be caused.

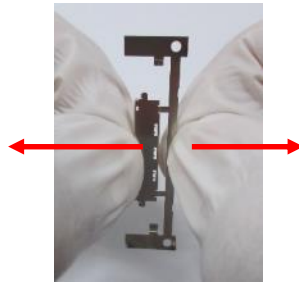

Photo.17 Cut by Force (Bad Example)

## 5-5. Assembly of Shell-A

- ① As show in Figure 5, shell-A is assembled from the upper side of housing assembly.

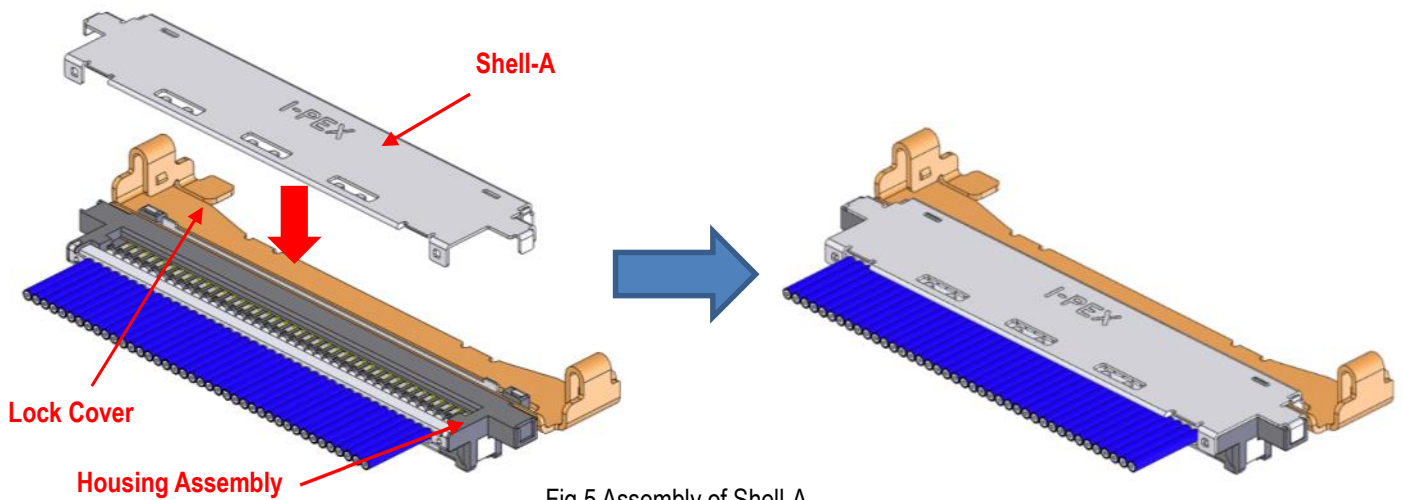

Fig.5 Assembly of Shell-A

- ② Confirms whether shell-A is assembled properly.  
Whether shell locks are assembled properly. (Fig.6★ Point)

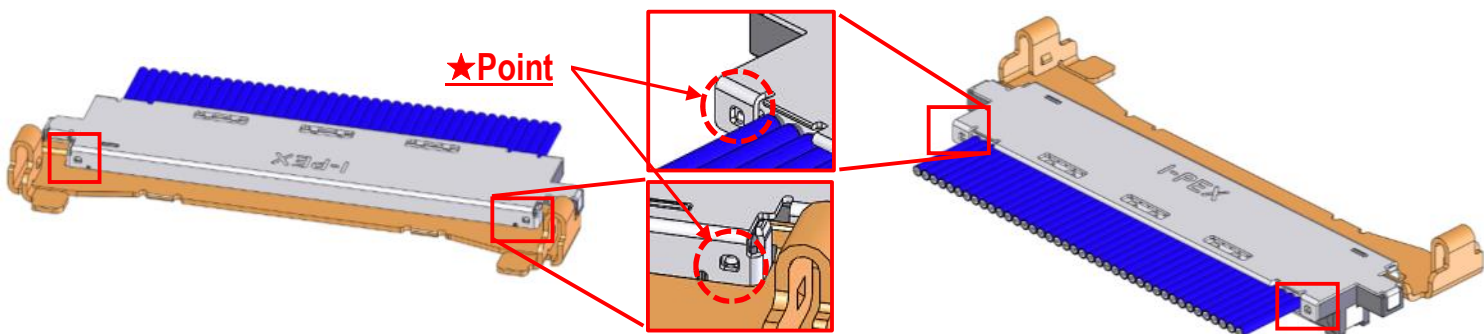

Fig.6 The Assembly Confirmation of Shell-A

- ③ Soldering shell-A, B and ground bar with the soldering iron at designated points is recommended. (Fig.7,8◆Point)

Refer to Fig.17 for a limit of the solder height. For conditions of Soldering iron refer to sheet 8.

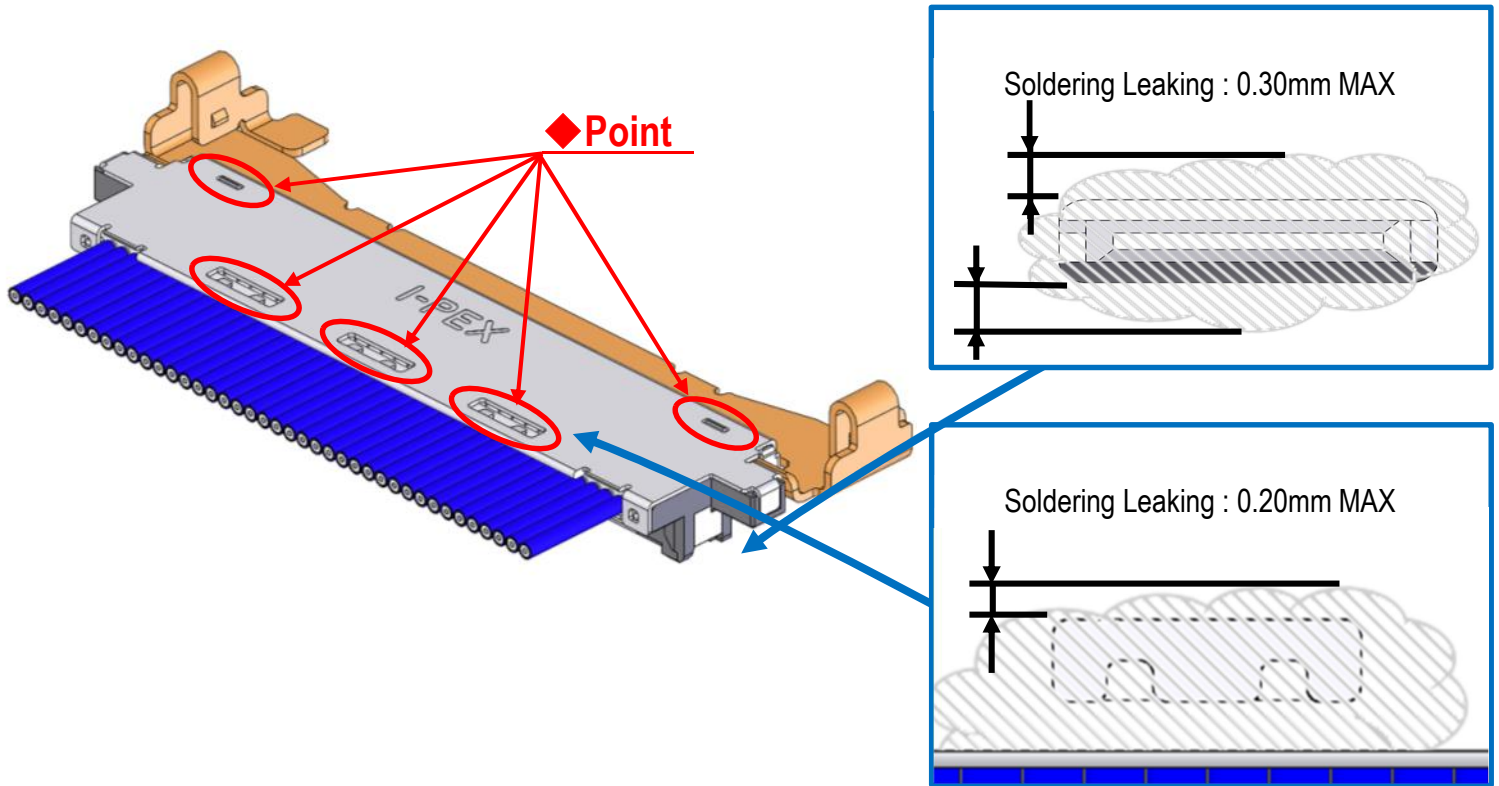

Fig.7 Soldering of Shell-A and Ground Bar

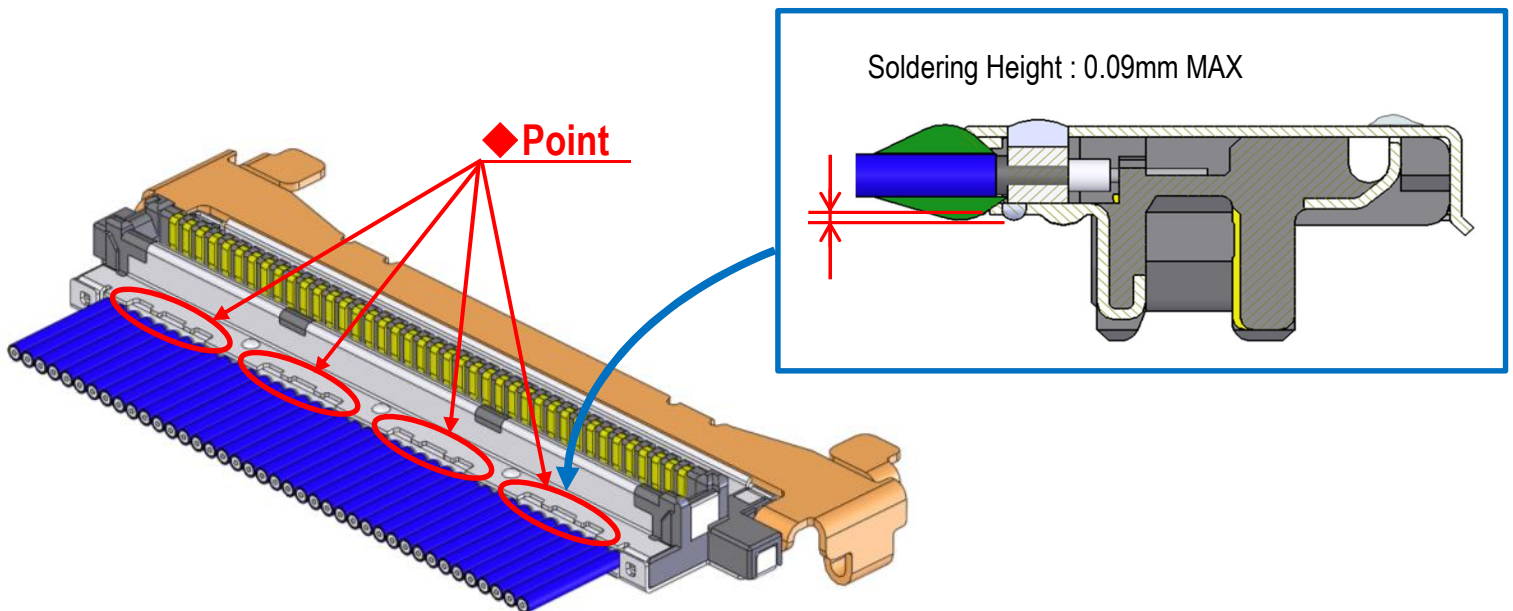

Fig.8 Soldering of Shell-B and Ground Bar

【When using pull tape holder without using lock cover】

## 5-5.Cautions in Treating Pull Tape Holder

Pull tape holder comes in a carrier tape wounded in a reel.

Follow the methods shown below to cut pull tape holder from carrier tape.

- ① Cut carrier tape along the green dotted cut line in Photo 18 by metal cutting scissors.

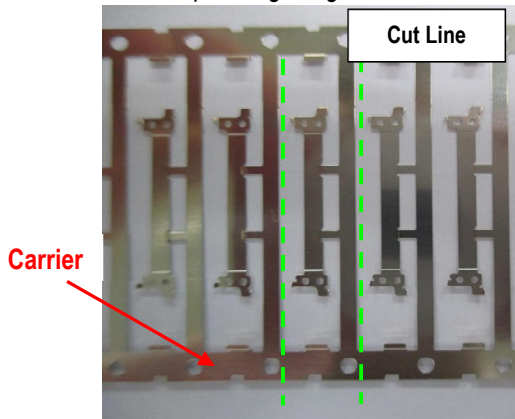

Photo.18 Before Cut

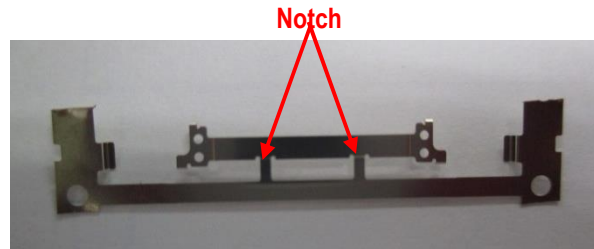

Photo.19 After Cut

- ② Hold the center of pull tape holder and bend it back and forth within  $\pm 45$  degrees to detach it from notch. Repeat until the pull tape holder is separated from the notch. Make sure no burr is found from cut off area. (Photos 20 and 21)

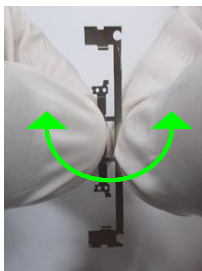

Photo.20 Cut Condition

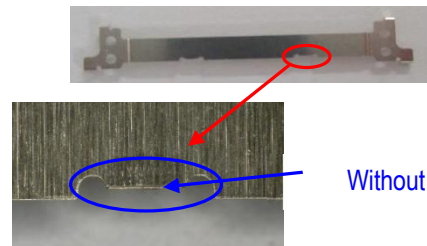
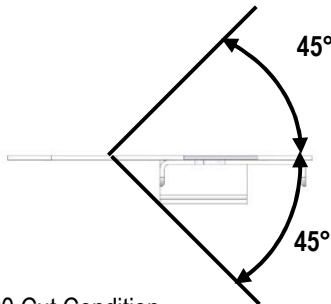

Photo.21 After Cut

Plug Detail of Notch



Photo.22 Bottom Side View



Photo.23 Upper Side View

Caution: Do not forcedly pull carrier toward red arrow direction or it may cause deformation or burr.

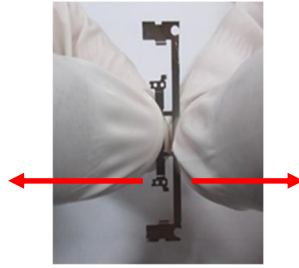

Photo.24 Cut by Force (Bad Example)

## 5-5. Assembling Pull Taper Holder

① Tape pull tape around pull taper holder as shown in Figure 10.

### • Recommended Pull Tape Dimensions

Positions	30P	40P	50P	60P	70P
Thickness	0.10 MAX				
A	7.4 ~ 9.7	11.3 ~ 13.7	15.3 ~ 17.7	19.3 ~ 21.7	23.3 ~ 25.7
B	10.0	14.0	18.0	22.0	26.0

\*Reference Material: Polyimide

Unit : mm

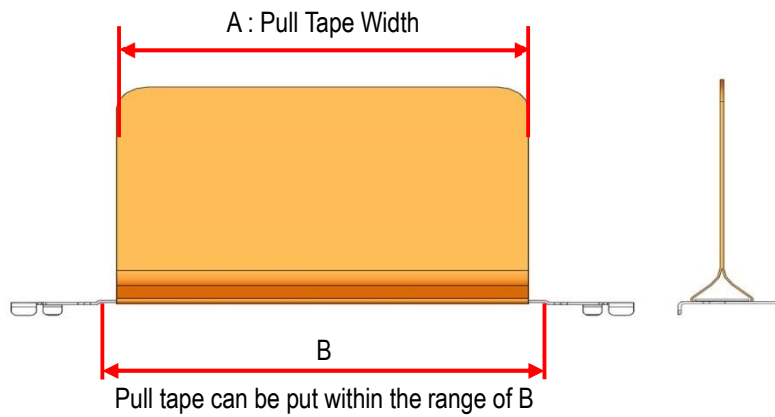

Fig.9 Pull Tape Dimensions

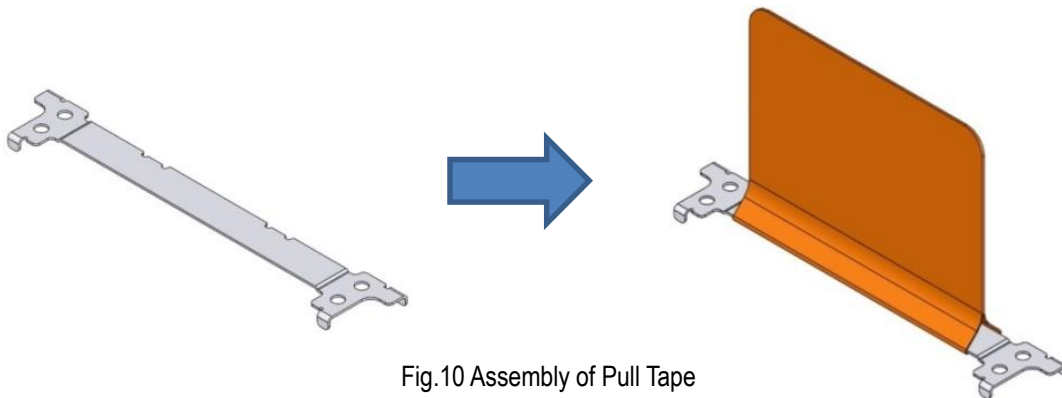

Fig.10 Assembly of Pull Tape

- ② Assemble the pull tape holder from upper surface of shell-A.

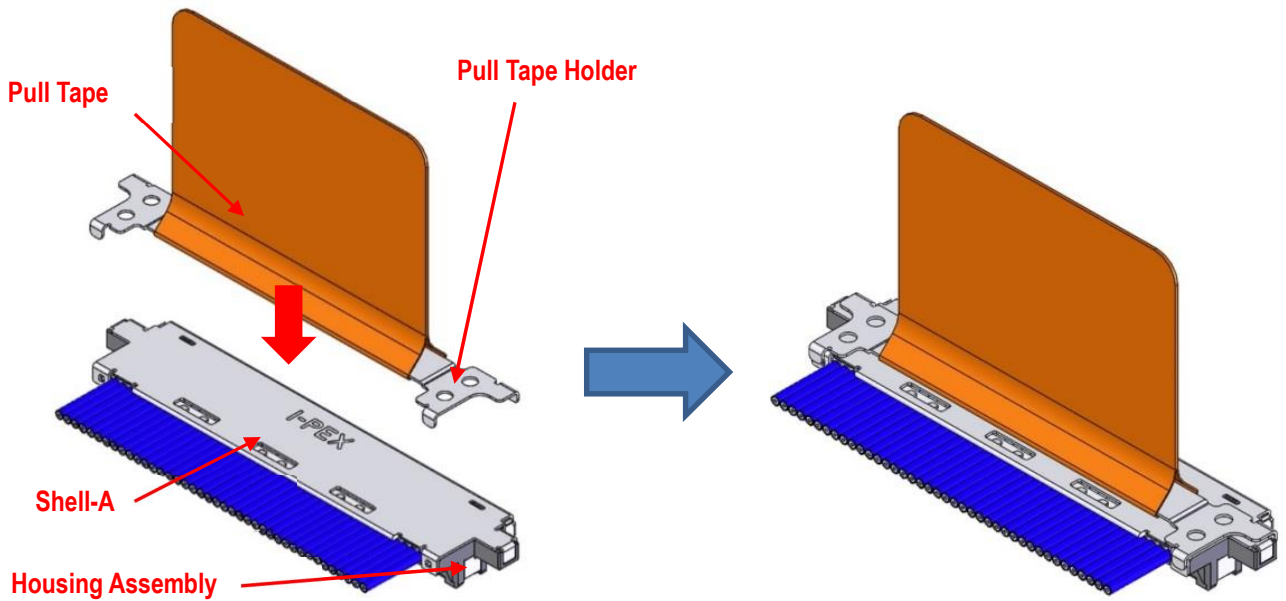

Fig.11 Assembly of Pull Tape Holder

- ② Make sure that pull tape holder is assembled properly.( Fig.12★Point)

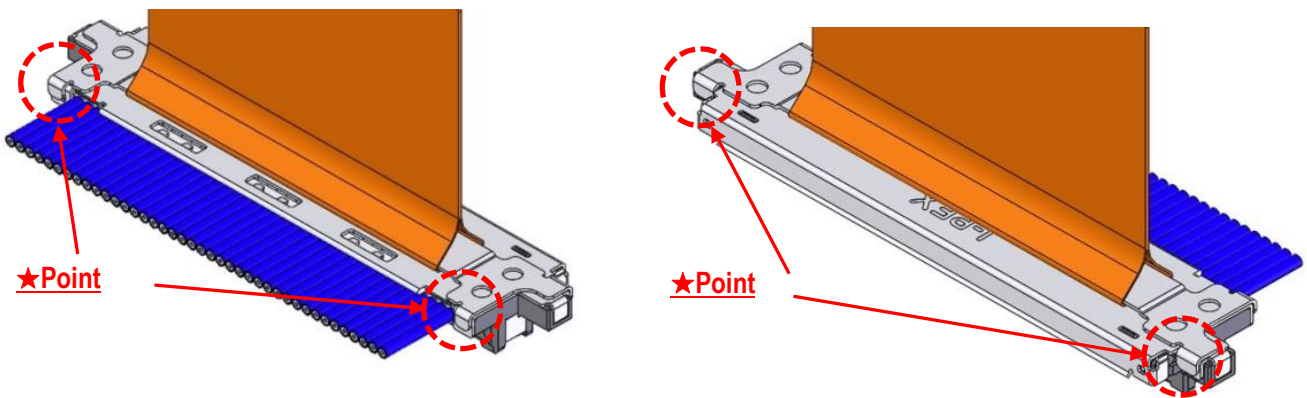

Fig.12 The Assembly Confirmation of Pull Tape Holder

- ③ Use soldering iron to solder pull tape holder and Shell-A. (Fig.13◆Point)

Refer to sheet 8 for soldering conditions.

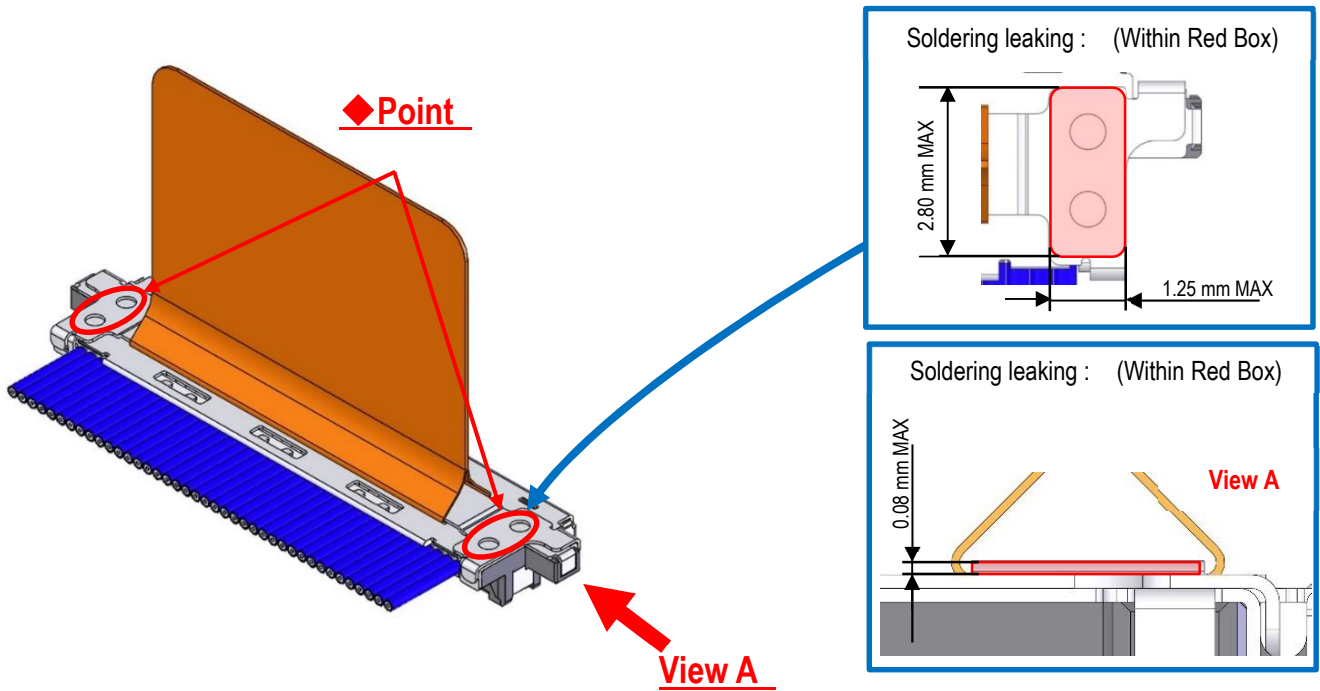

Fig.13 Soldering of Pull Tape Holder

**[70P Only – Additional Soldering]**

Solder Shell-A and Shell-B at the ◆ points shown in Fig. 14 after completing Step 4.

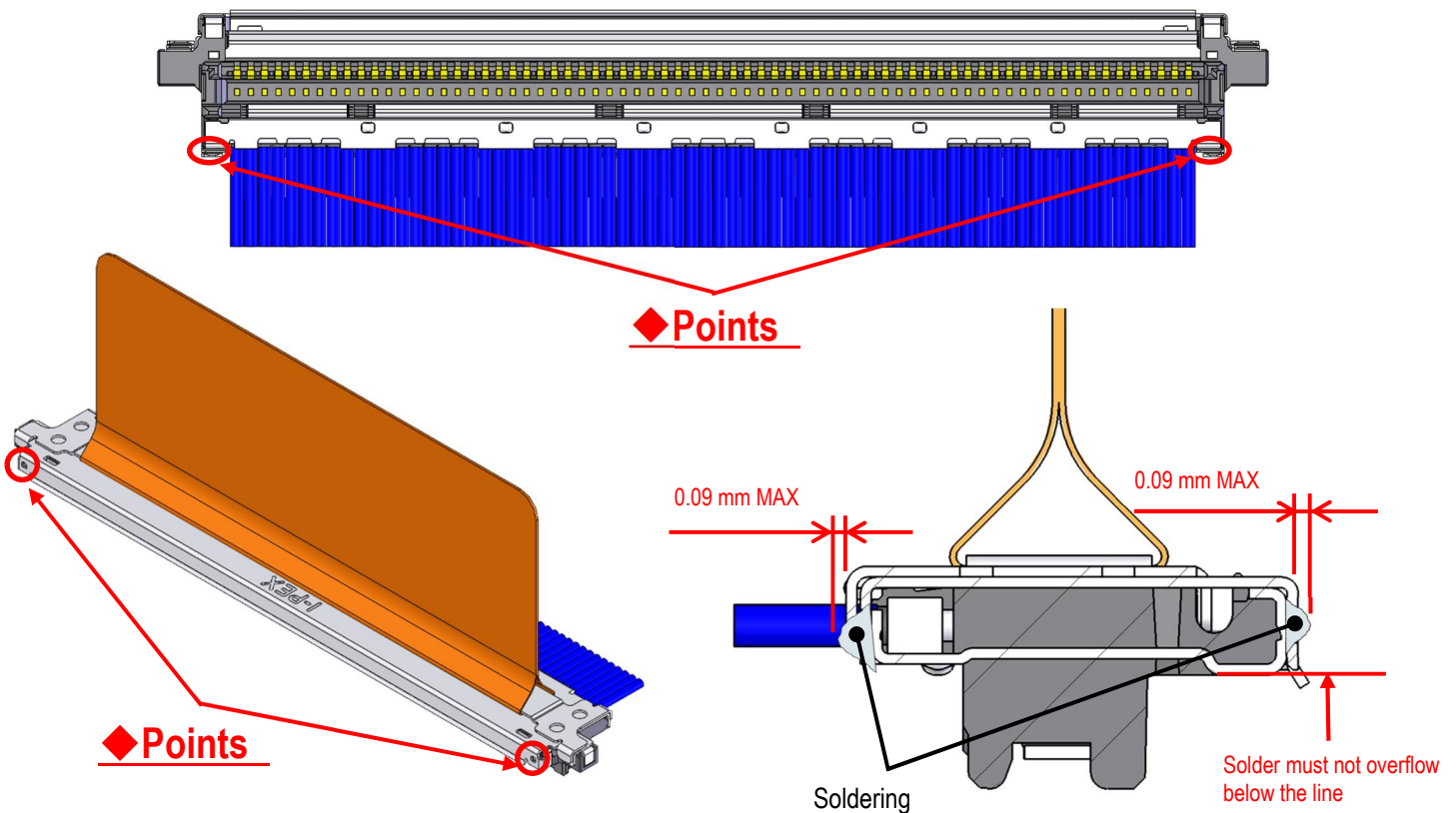

Fig.14 Additional Soldering Points for Shell-A and Shell-B

**[Caution]**

\*Do not place pull tape holder upside-down.

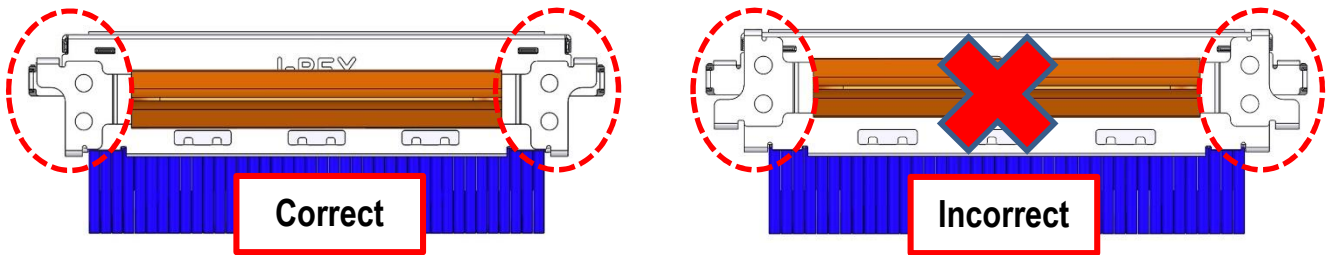

Fig. 15 Assembling Pull Tape Holder

\*If pull tape holder is unstable, secure it before soldering.

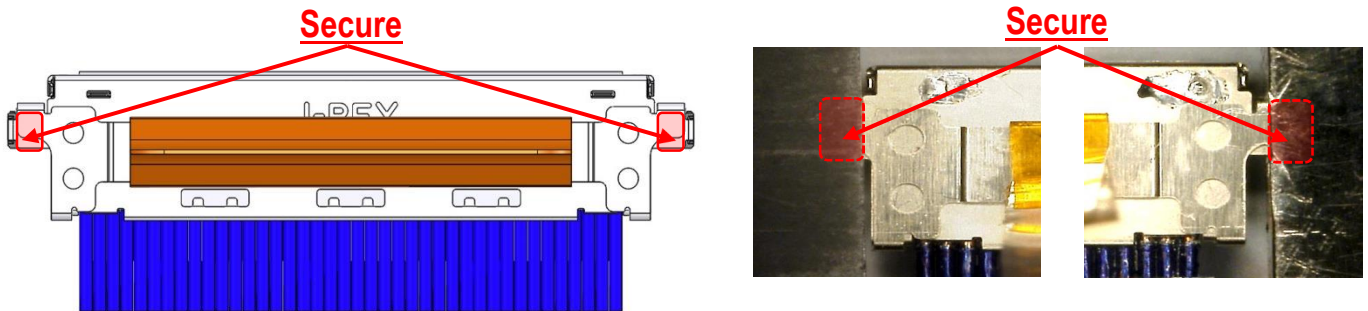

Fig.16 Secured Pull Tape Holder

\*If soldering paste amount is not enough, strength of pull tape holder may decrease.  
Make sure all four holes are soldered as shown in correct photo.

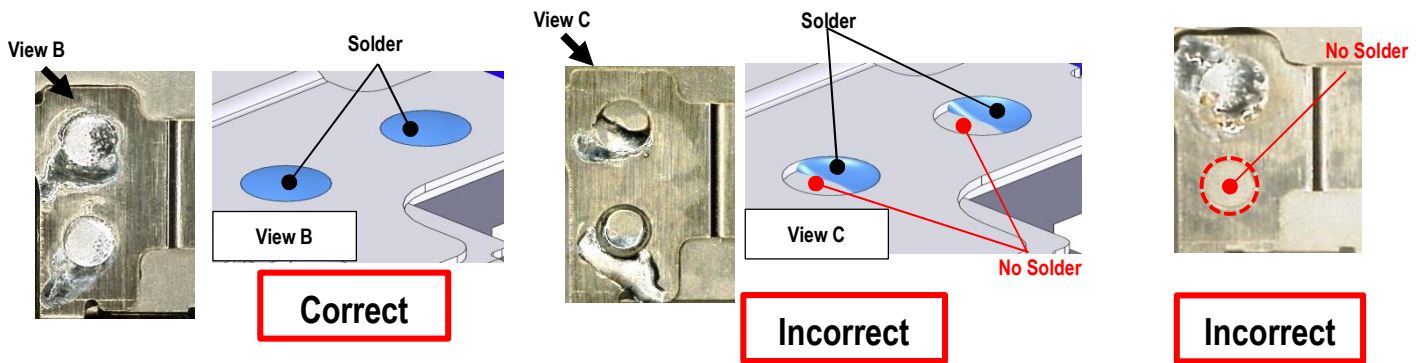
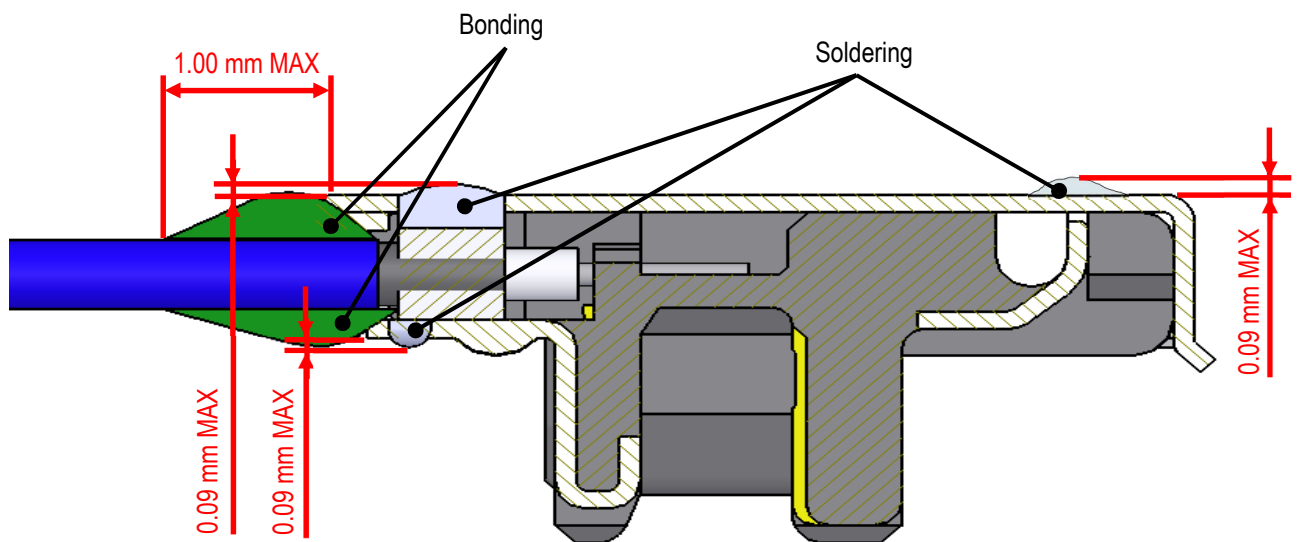
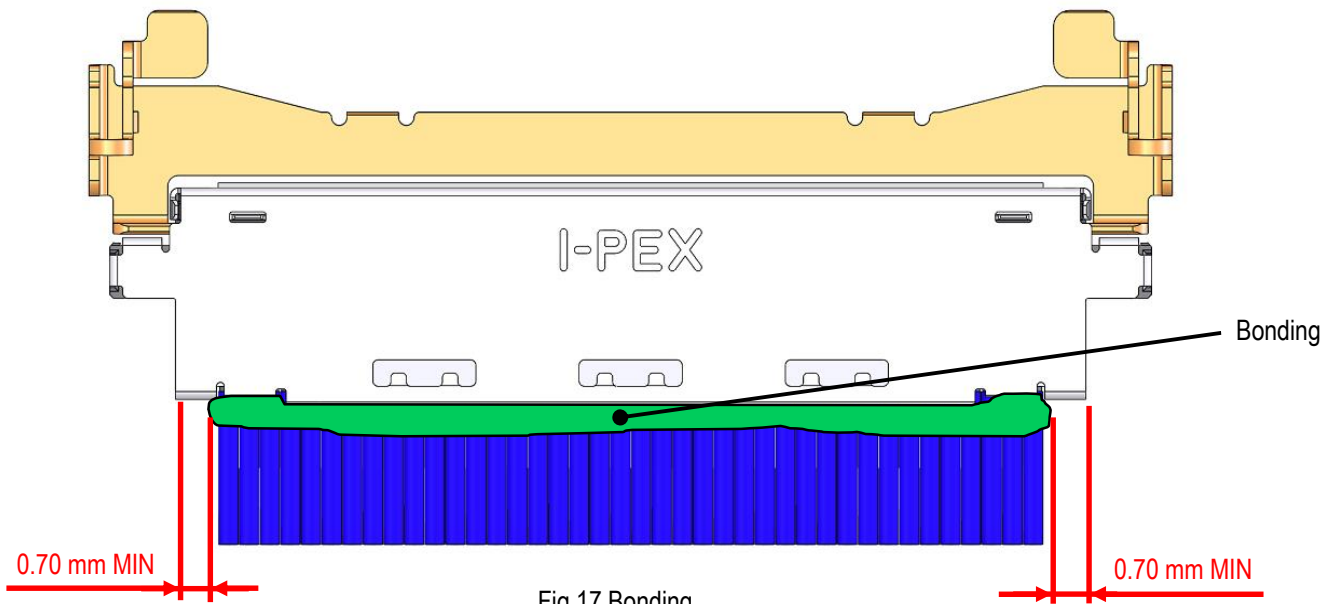

Photo.25 Soldering

\*Do not touch pull tape with soldering iron or it may melt it according to the heat-resistant temperature.

## 5-6. Cable Fixation

Fix the cable terminal part with the bond. Recommended bond: LOCTITE 352



## 【Caution】

\*Do not tape the prohibition area or lock cover may not work properly.  
Bundle the cable as shown in Figure 19 and 20.

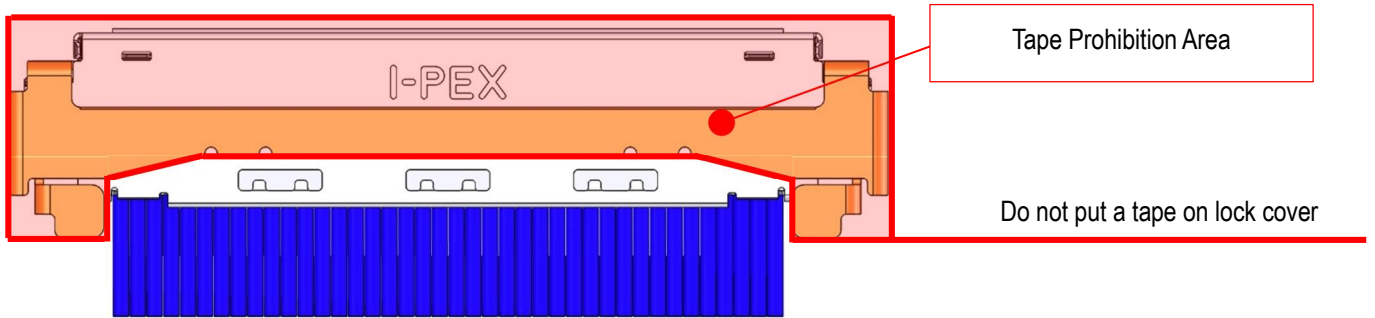

Fig.19 Top Surface Tape Prohibition Area

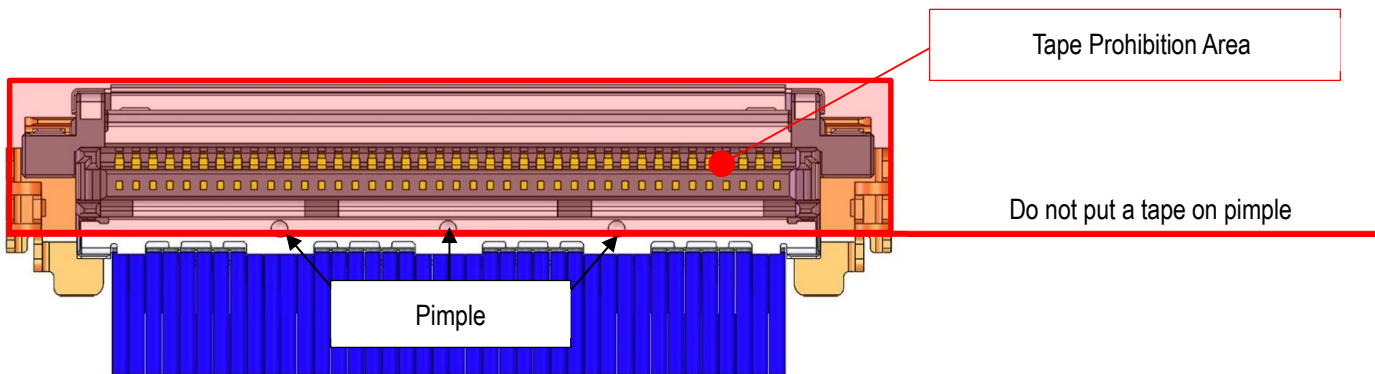

Fig.20 Bottom Surface Tape Prohibition Area