

CABLINE®-CX II PLUG Without Cover

Part No. 20978

Assembly Manual

2	S22450	October 6, 2022	K.Baba	R.Takei	H.Ikari
1	S19504	September 4, 2019	S.Yamaguchi	T.Kurachi	H.Ikari
0	S17869	November 27, 2017	R.Hoshino	T.Yayoshi	M.Takemoto
Rev.	ECN	Date	Prepared by	Checked by	Approved by

1. Purpose :

This manual is to explain the soldering method / process of the CABLINE-CX II PLUG with cable, and assembly of SHELL-A, LOCK BAR.

2. Applicable connector :

Name: CABLINE-CX II PLUG

Parts No.:

Set P/N	WITHOUT COVER CABLE ASS'Y	20978-040T-01
Discrete P/N	HOUSING ASS'Y	20974-040T-01
	SHELL-A	3655-0401
	LOCK BAR	3656-0402

3. Fixtures :

3-1. Components and Instruments used in the condition confirmation

- Pulse heater

Name	P/N	Manufacturer
Reflow head	NA-66	Nippon Avionics Co., Ltd.
Pulse heat power supply	TCW-215	Nippon Avionics Co., Ltd.

- Heater chip

Positions	40P
Thickness	0.30 ⁰ _{-0.05}
Width	10.80 ⁰ _{-0.03}

Unit: mm

- Recommended solder bar

Resin-free solder made by Uchihashi Estec Co., Ltd. was used.

Positions	40P
Solder size	φ0.06
Length	10.7 Ref.

Unit: mm

4. Recommended pulse heat condition

	Micro-Coax
① Idle temp.	150°C
② 1 st heat temp.	220°C
③ " rise time	0.5sec.
④ " holding time	2.0sec.
⑤ 2 nd heat temp.	320°C
⑥ " rise time	0.5sec.
⑦ " holding time	5.0sec.
Heater tip Pressure	11N

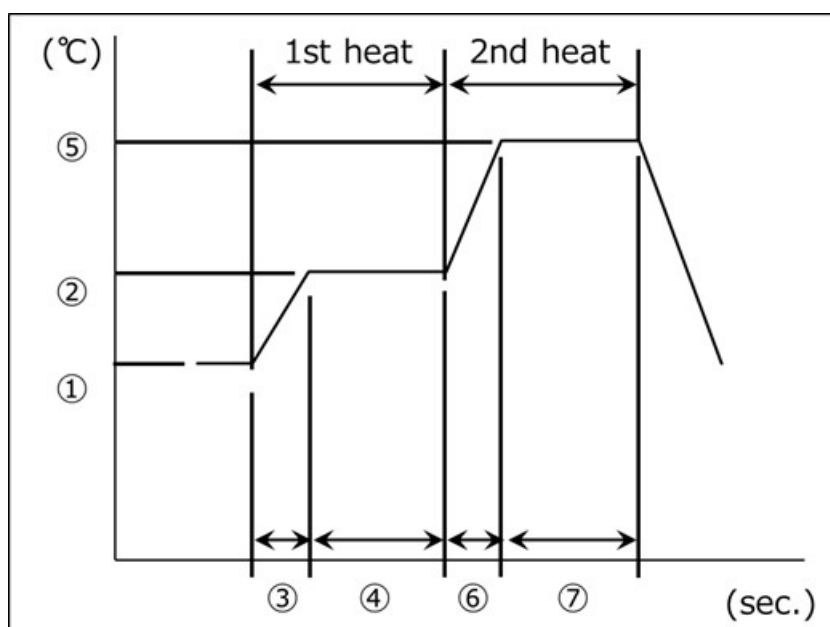

※This pulse heat condition was evaluated and confirmed by our pulse heat jig and instruments.

The most optimum condition may change based on the shapes of pulse heat jig and instruments, the environments, or other reason.

Therefore, please examine the pulse heat condition adequately in advance of use.

5. Work procedures :

5-1. Soldering of center-conductor

① The cables have to be fabricated as shown below in advance of soldering.

[Micro coax cable]

Unit: mm

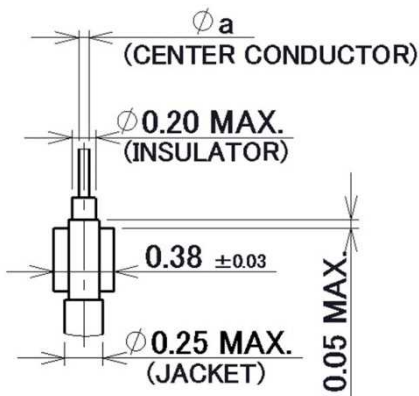
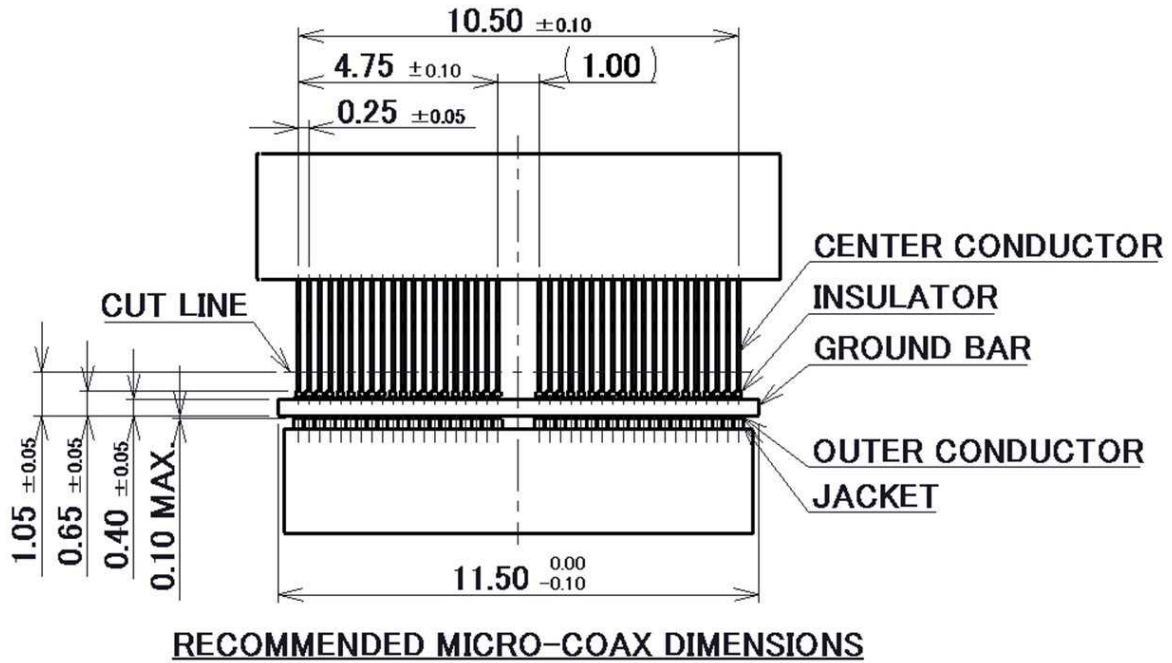

MICRO COAX CABLE DIMENSION

	a
#39	0.102
#44	0.063
#46	0.048

Micro coax cable #39 :

Not recommended for high speed signal transfer

[Discrete cable]

Unit: mm

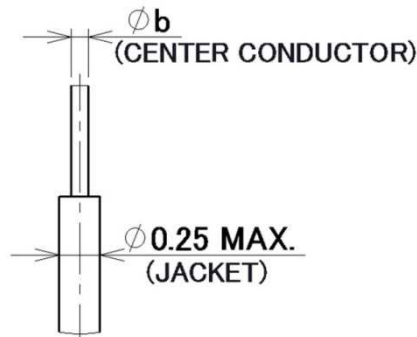
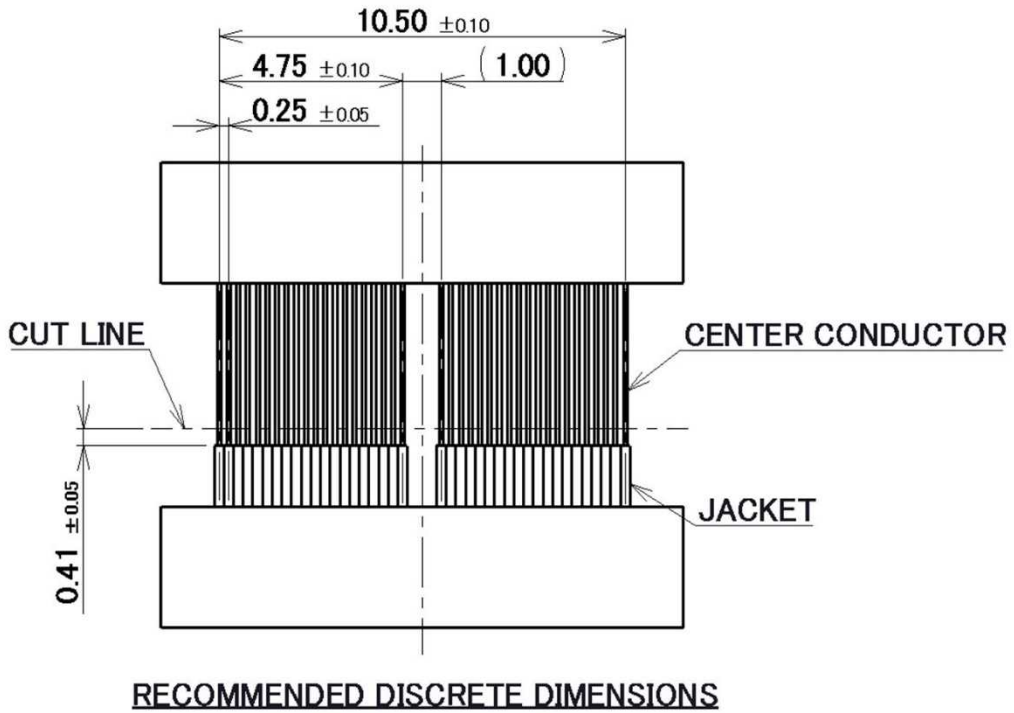

DISCRETE CABLE DIMENSION

	b
#39	0.102

- ② Apply flux to contact by the dispenser etc., and please confirm all contacts were applied flux.

Applying Flux area

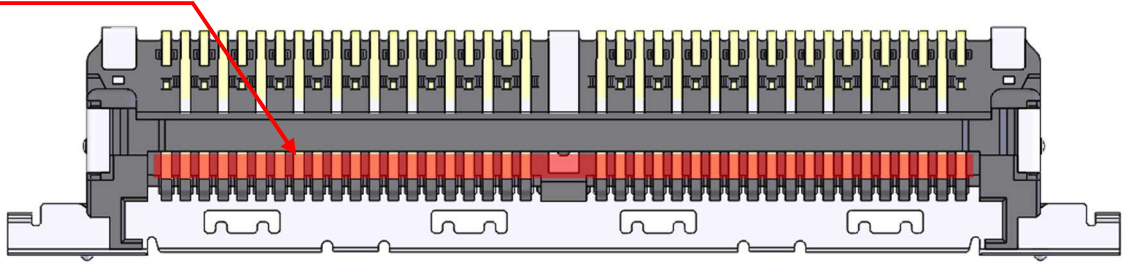

Fig.1 After applying flux

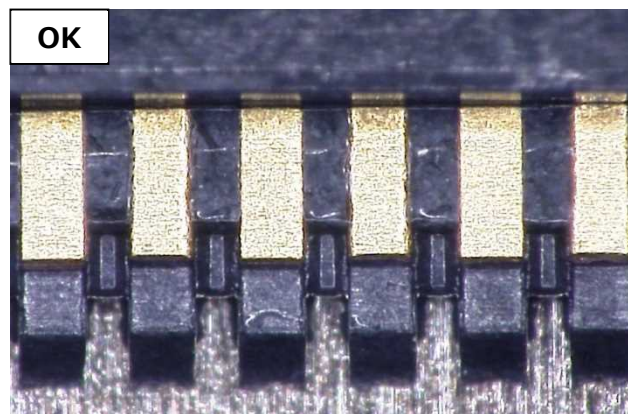

Photo.1 After applying flux

- ※Please do not apply flux too much like Photo.2. It can cause flux splash or leak to the mating area.

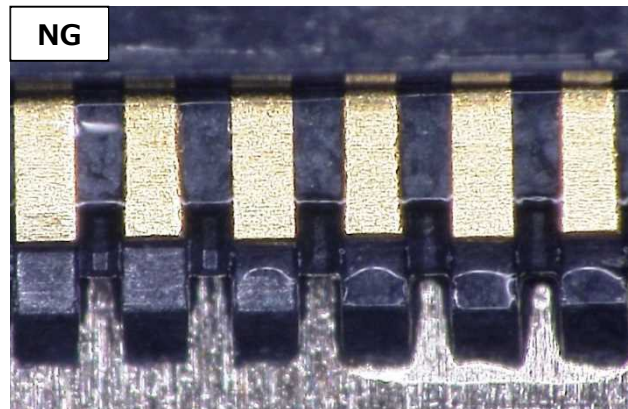

Photo.2 Extra flux

- ※Washer must not be used to take flux off because it may cause flux attached to mating area.

- ③ Pre-set and locate solder bar at center of soldering point.

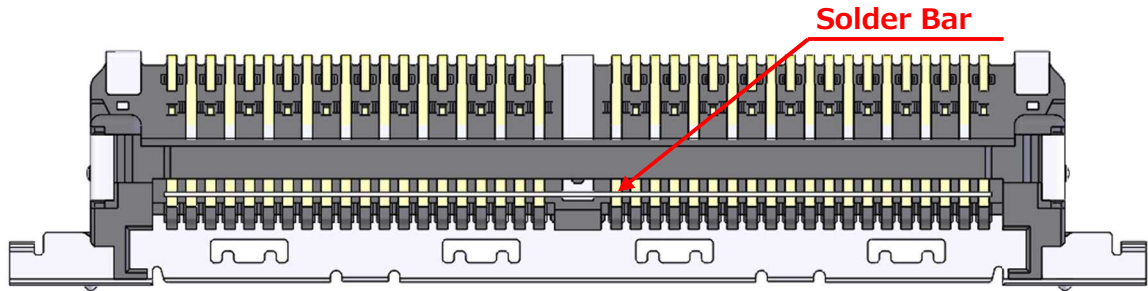

Fig.2 Set solder bar

- ④ Set the cable.

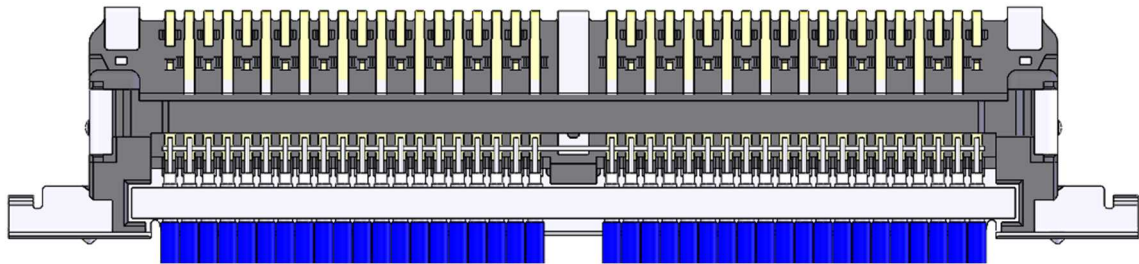

Fig.3 Setting Cable (MCX)

※When using a discrete cable, set it so that the end of the jacket and the end of the product rib match.

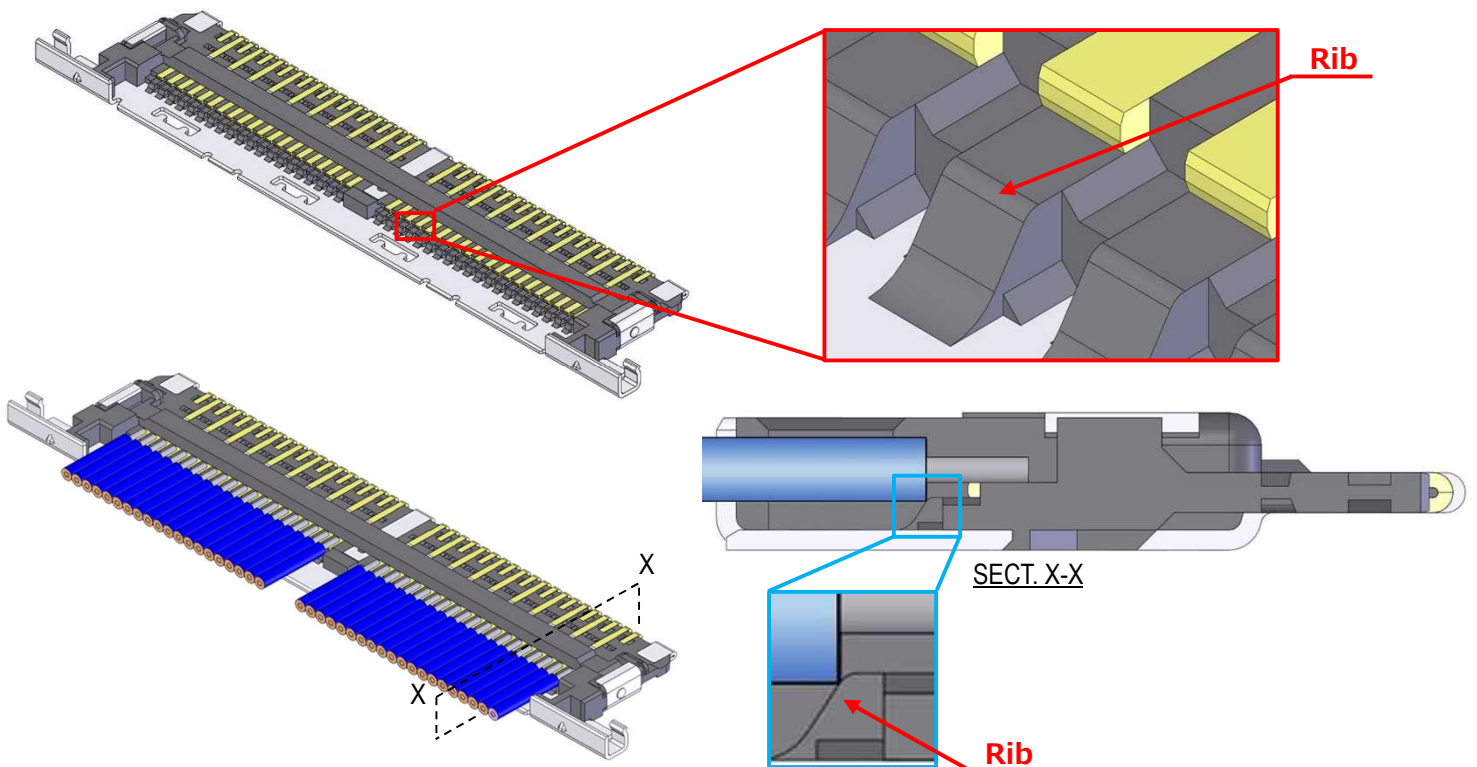

Fig.4 Setting Cable(Discrete)

- ⑤ Solder the cable center conductor and connector with pulse heater.
See photo.3 of soldering condition.

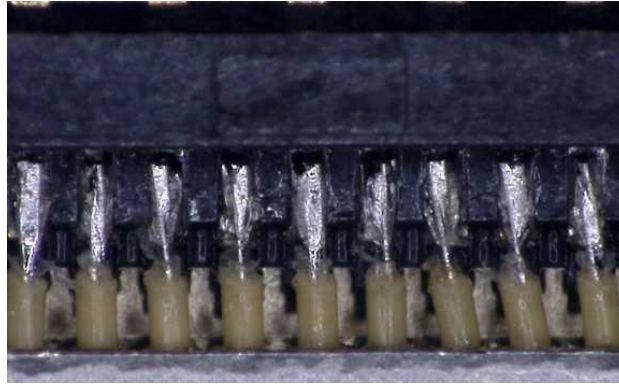

Photo.3 AWG#44

- ※When solder bridge is appeared between the terminal,
try heating again with pulse heater only one time.
If the bridge isn't repaired, repair only the NG point with a soldering iron.

Condition of Soldering iron : 50W
Operating temperature : 350℃
Application time of soldering iron : Within 5sec.

※When using a discrete cable, please apply an insulating tape to the connection before assemble SHELL-A.

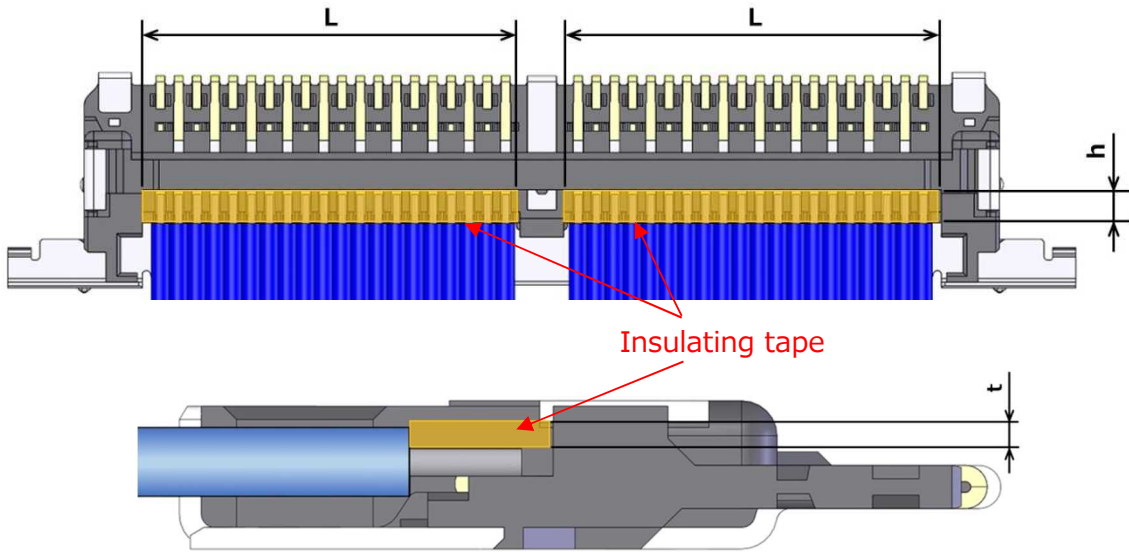

Fig. 5 Insulating tape position

Please do not hang on HOUSING and cable jackets.
It might cause the SHELL-A float.

Unit: mm

L	h	t
5.10	0.40	0.07 MAX.

Caution: Do not forcibly pull the cable toward red arrow direction after soldering or apply excessive load on the soldered area, or it may peel the solder. (Fig.6)

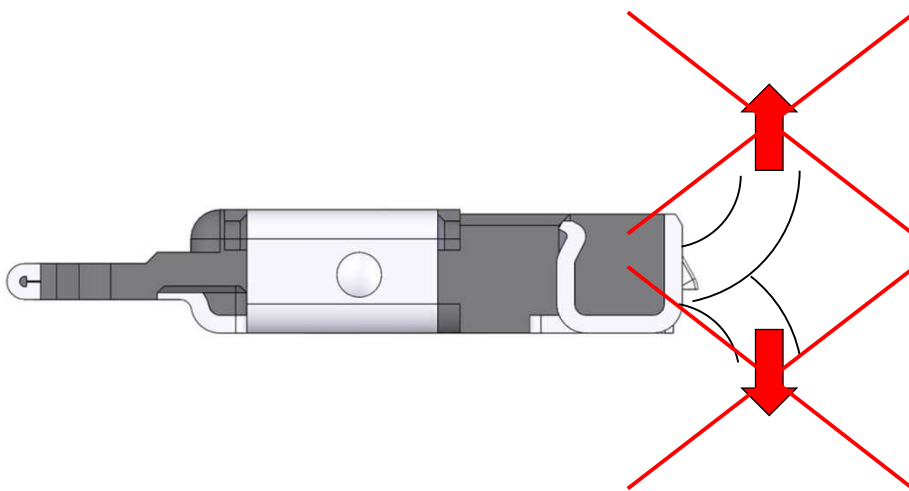

Fig.6 Cause of solder peeling

5-2. Cautions in treating SHELL A

SHELL A is delivered in the reel with a carrier. The following is the method to cut SHELL A from Carrier.

- ① Cut carrier on the cut line of the left below picture (green line) by a scissors for metal.

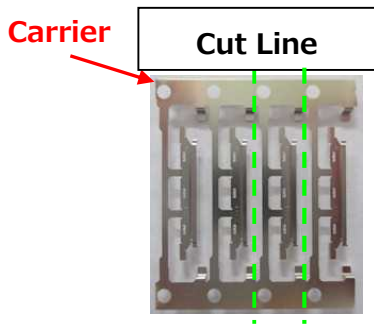

Photo.4 Before cut

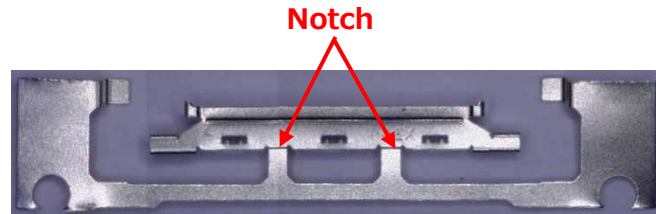

Photo.5 After cut

- ② Hold the center of Plug shell-A and cut it off from Notch by ± 45 deg of reciprocating work. When it does not be cut, try again this reciprocating work.

After separated, check there is no burr around the cut part. (Photo.7)

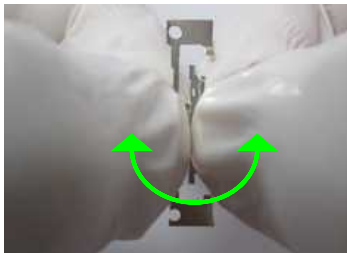

Photo.6 Cut condition

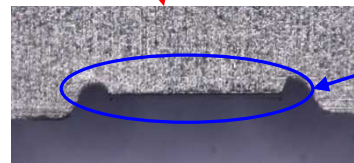
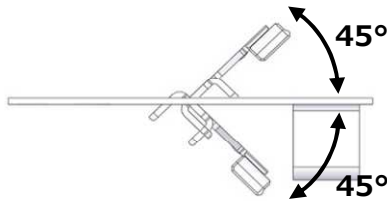

Photo.7 After cut

SHELL-A Detail of Notch

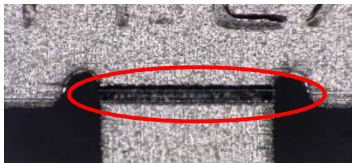

Photo.8 Upper side view

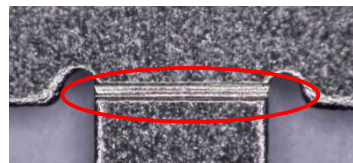

Photo.9 Bottom side

Caution: By pulling like the photo below to cut off by force (Red arrow direction), burrs and transformation can be caused.

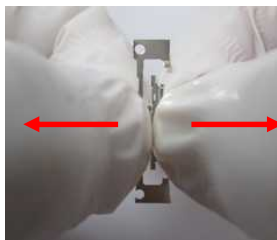

Photo.10 Cut by force (Bad example)

5-3. Assembly of LOCK BAR

LOCK BAR is assembled to HOUSING ASS'Y.

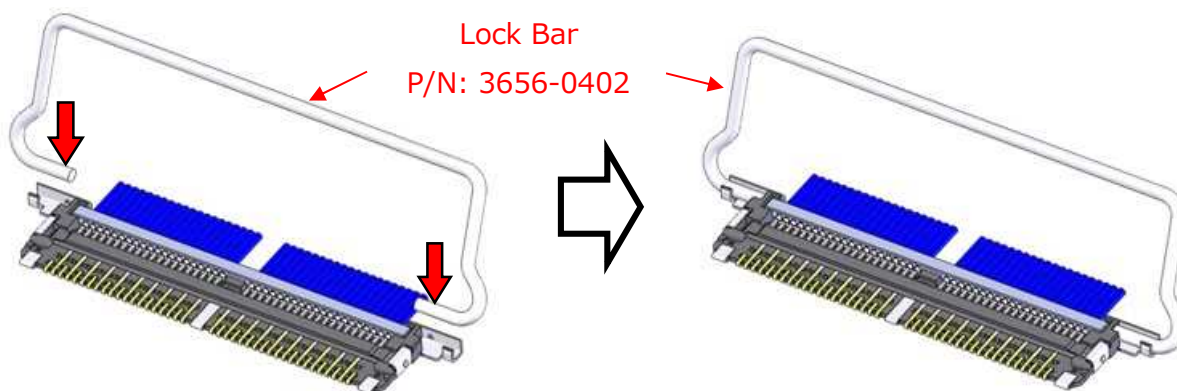

Fig.7 Assembly of LOCK BAR

5-4. Assembly of SHELL-A

- ① LOCK BAR is tilted to the cable side.

Place the SHELL-A on the upper surface of the HOUSING ASS'Y and push only the red shaded areas to assemble them.

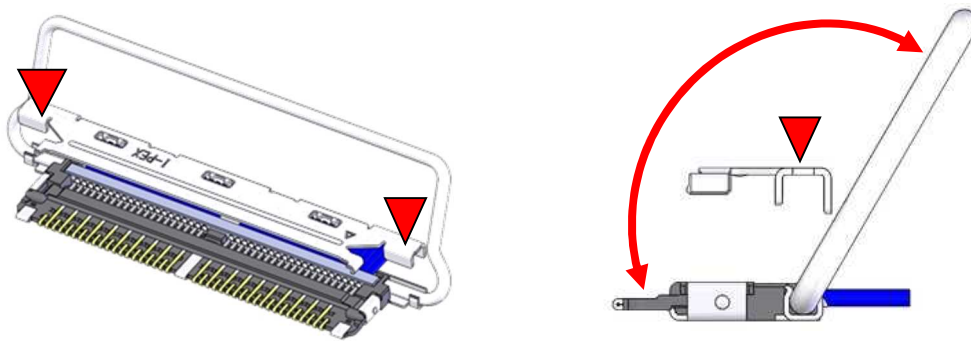

Fig.8 Assembly of Shell A

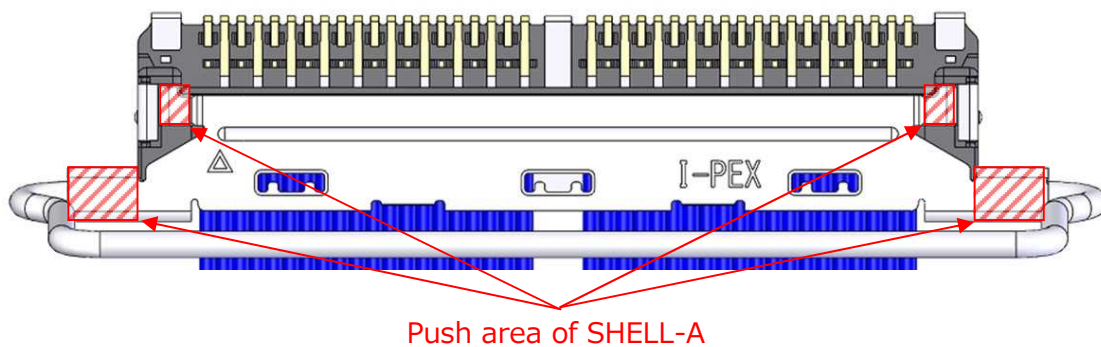

Fig.9 Push area of SHELL-A

※Check ★ point ①(Fig.10) from the front of connector as shown below.

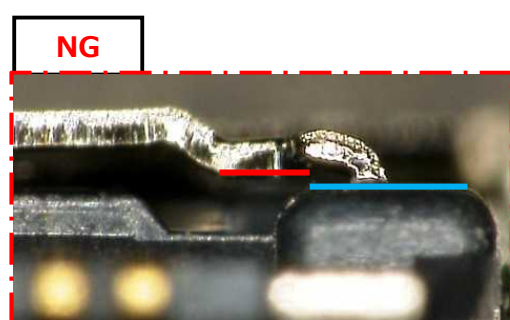
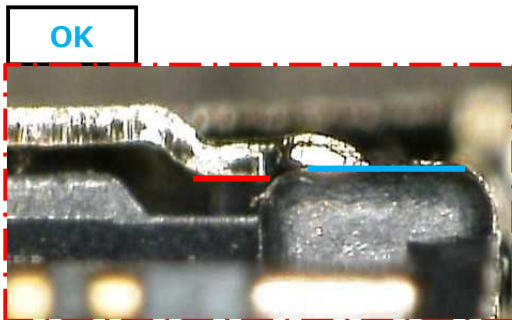
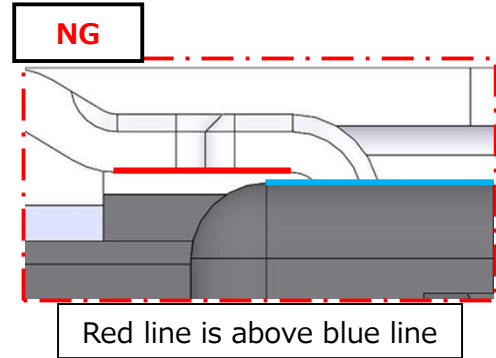
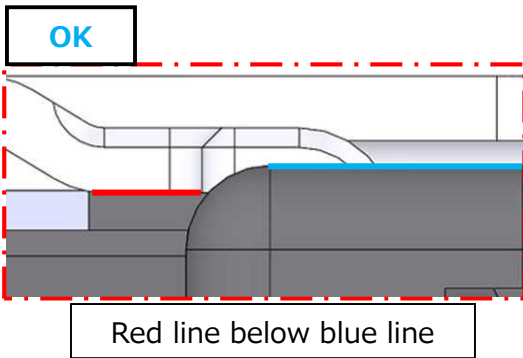
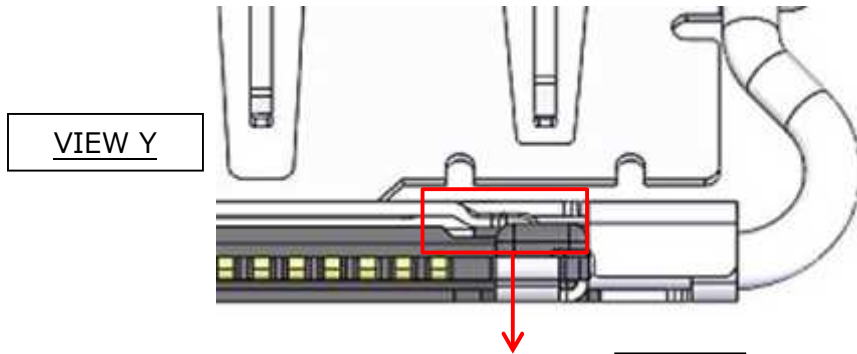
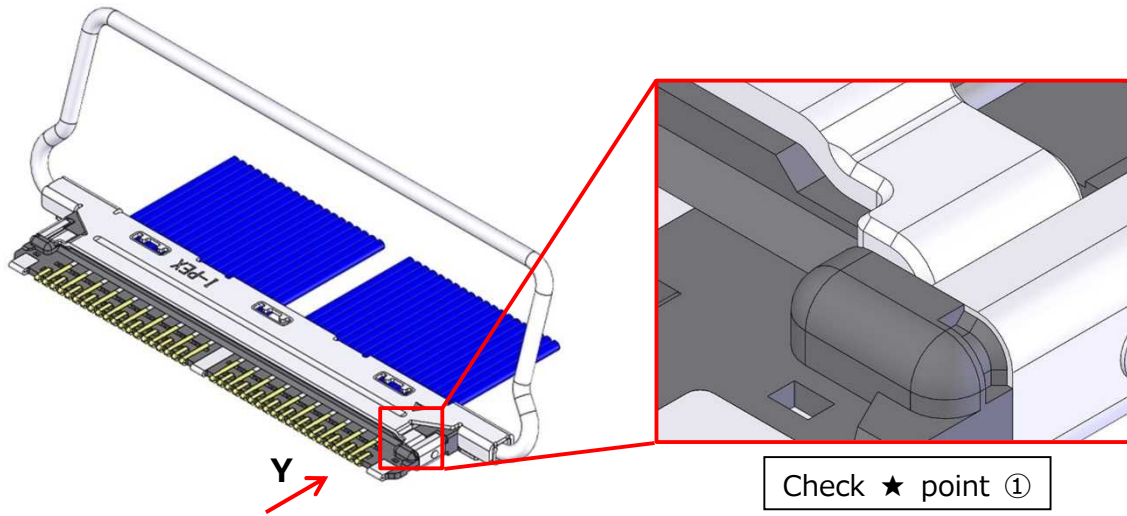

Fig.10 Confirm whether SHELL-A

※Confirm whether (Fig.11 ★ points ②,③) is assembled properly and SHELL-A locks properly.

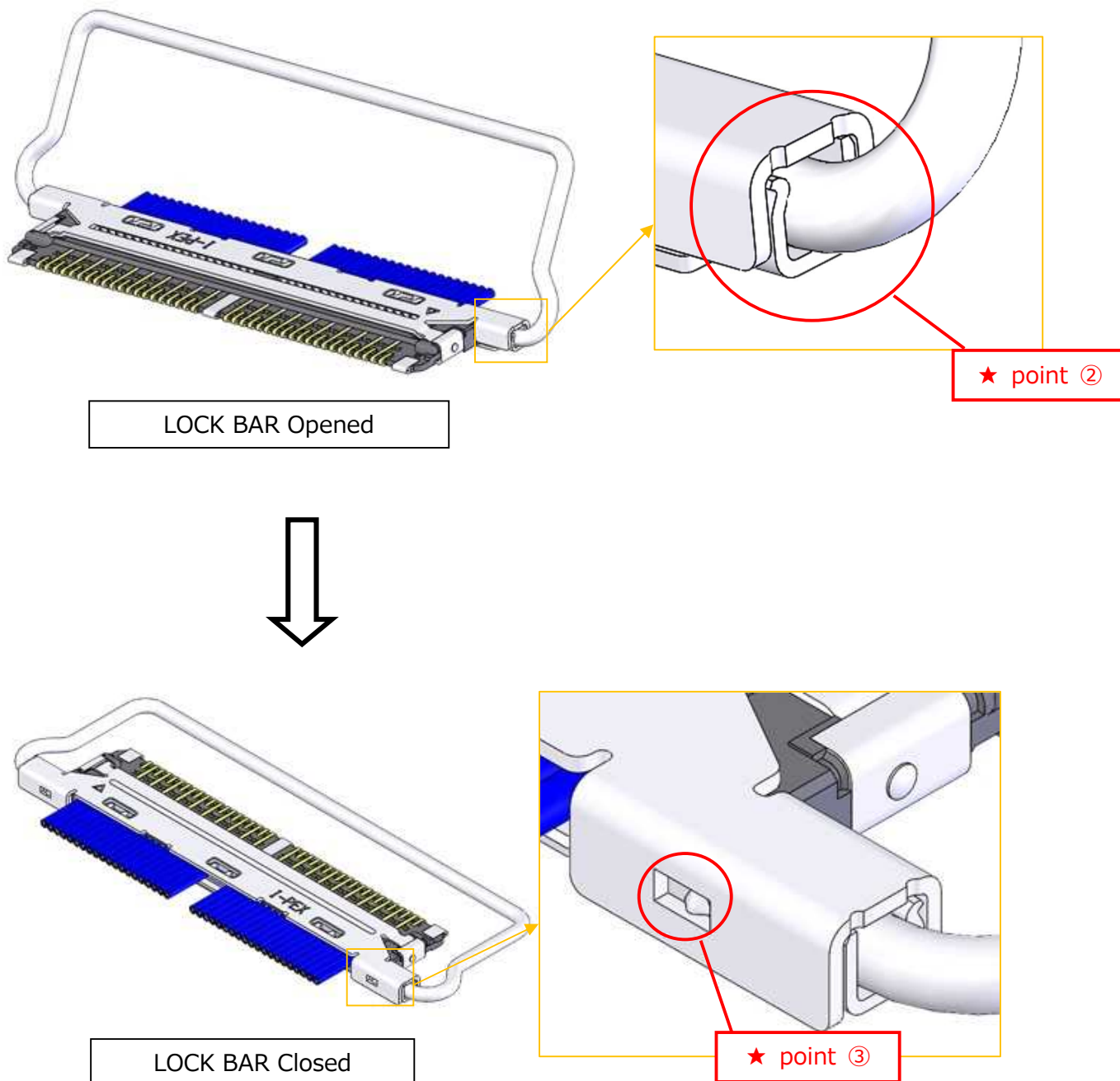

Fig.11 Assembly of SHELL-A

- ② Soldering SHELL-A, B and Ground Bar with the soldering iron at all designated points is recommended. (Fig.12,13 ◆point)
Conditions of Soldering iron refer to sheet 8.

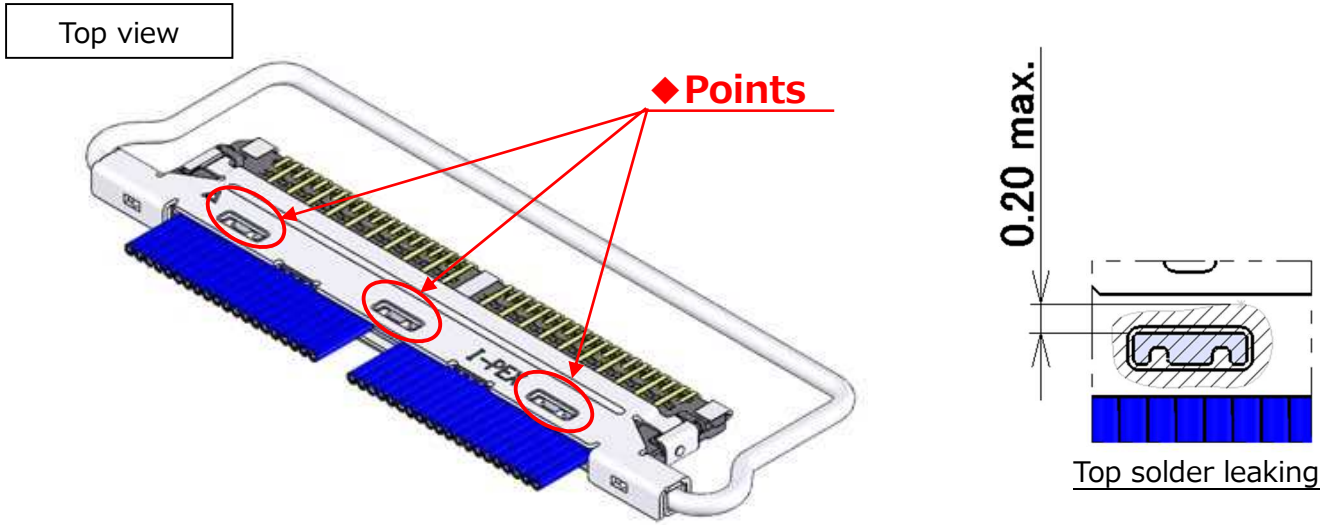

Fig.12 Soldering of Shell-A and Ground Bar

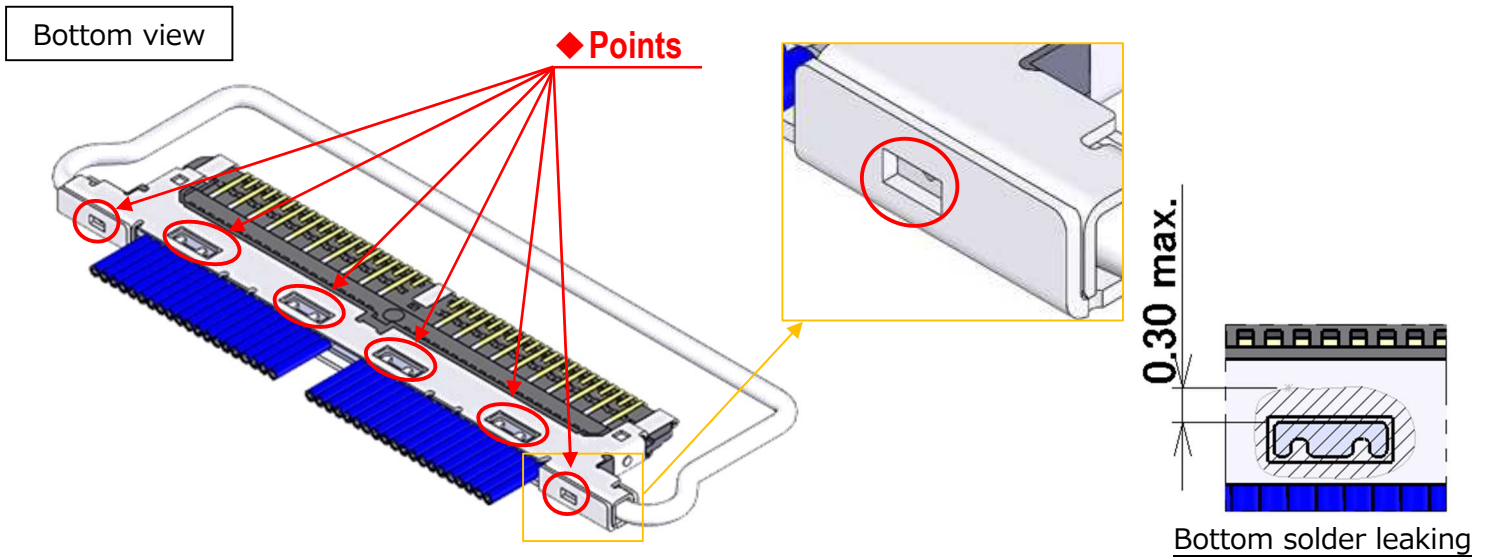

Fig.13 Soldering of Shell-B and Ground bar/ Shell-A and Shell-B

※When soldering, do not press the soldering iron against the connector with excessive force.
There is possibility of connector deformation.

5-5. Cable fixation

Fix the cable terminal part with the bond.

Recommended Bond: LOCTITE 352

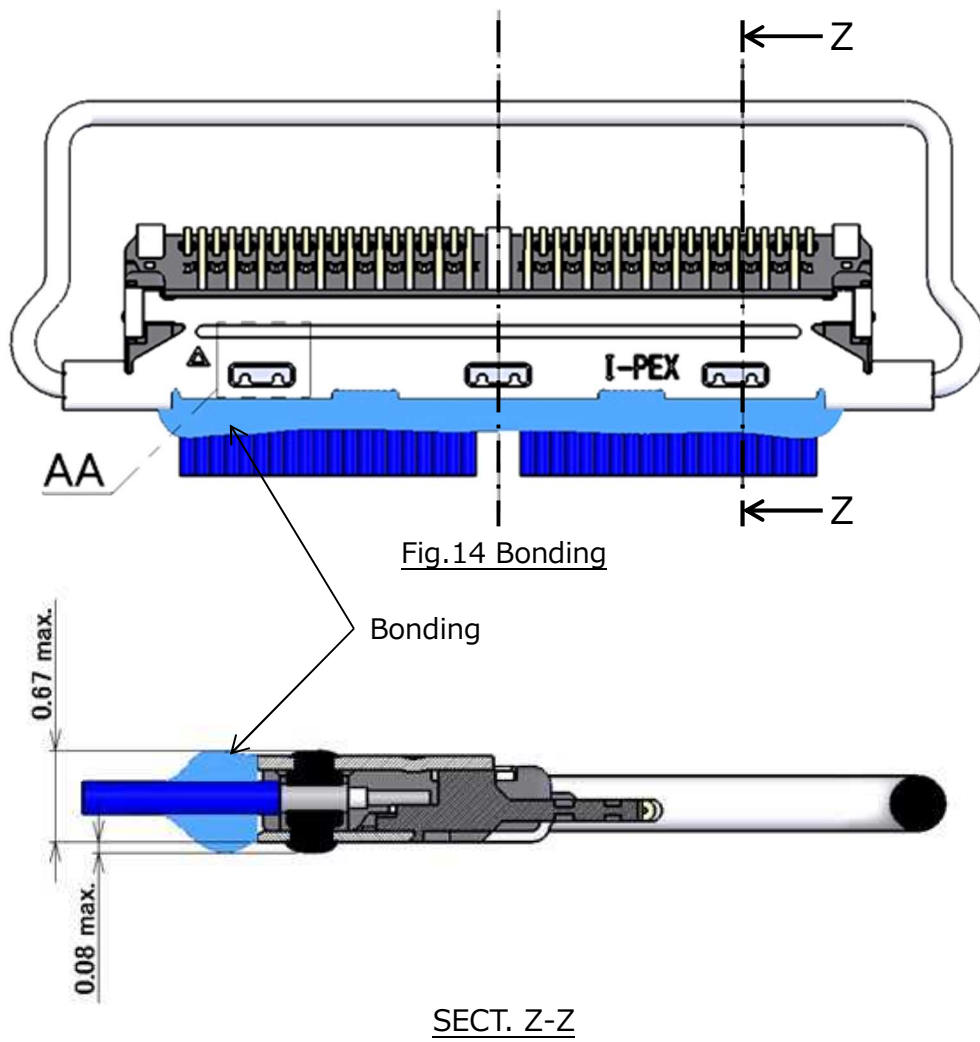

Fig.15 Soldering / Bonding