

Recommended P/N 21001-042E-01

PART No.  
21001-042E-01

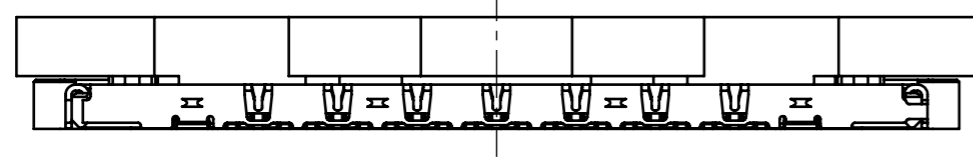

1.48 ±0.15  
WITH VACUUM CAP

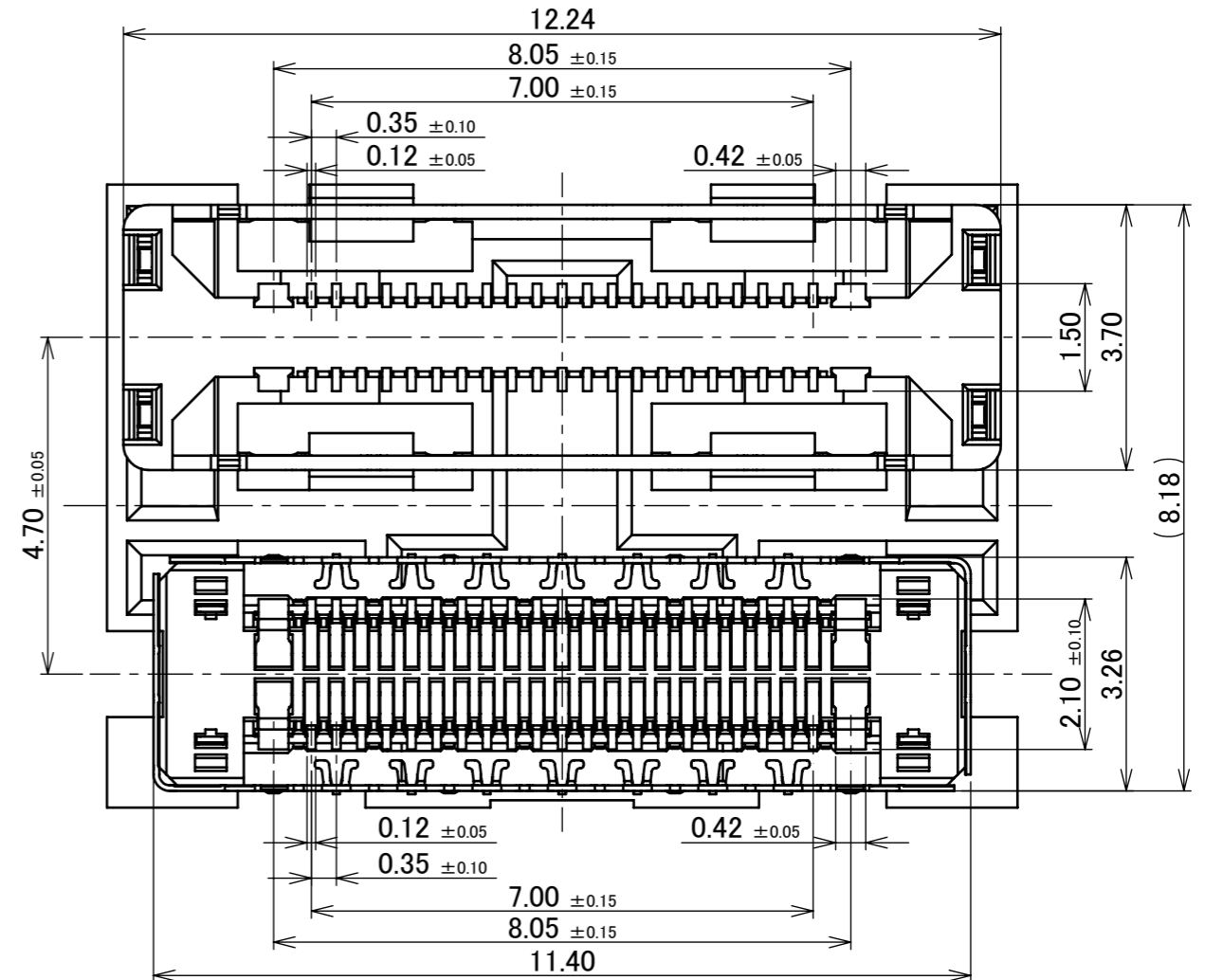
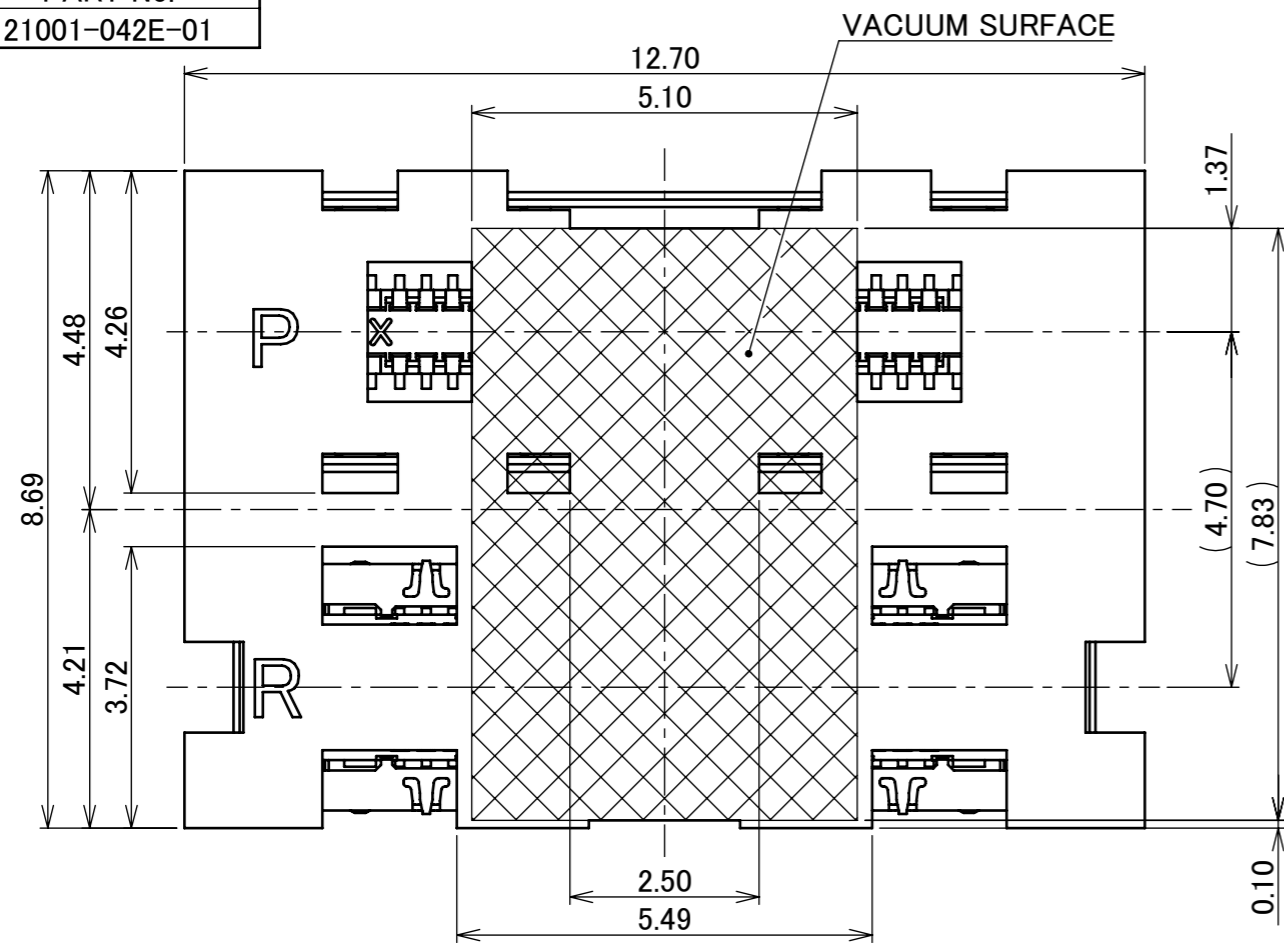
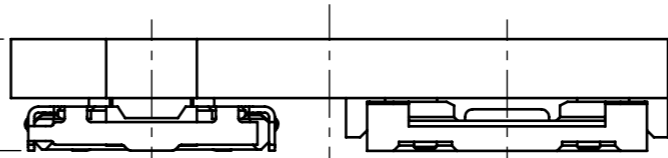

0.70 ±0.05  
MATING HEIGHT

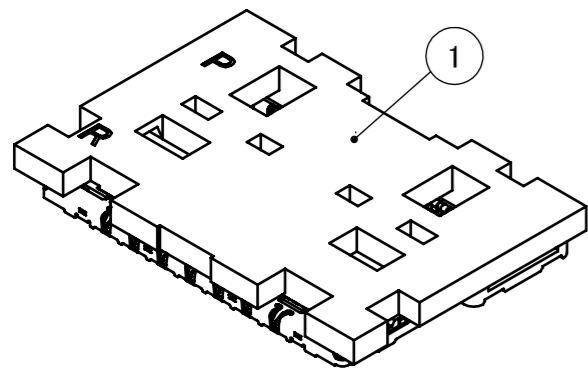
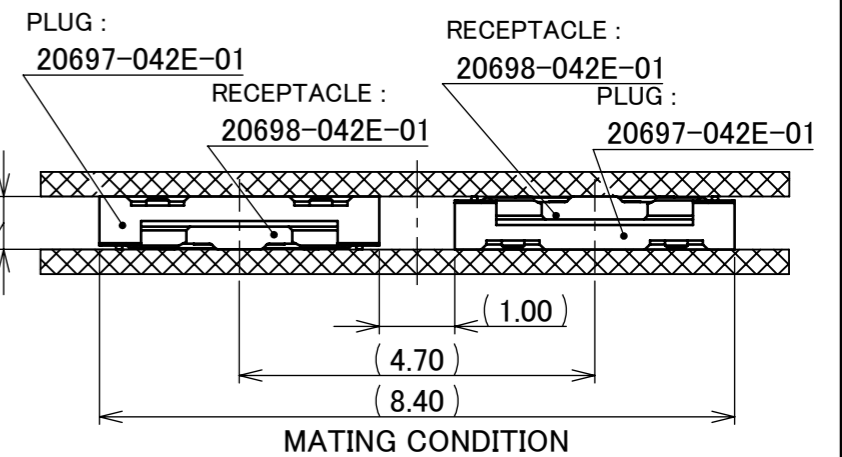

WITH VACUUM CAP

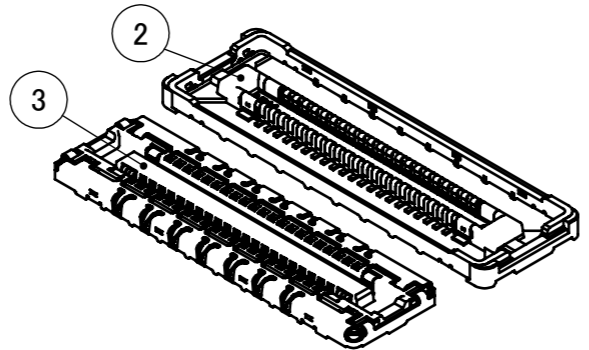

WITHOUT VACUUM CAP



Halogen Free



RoHS Compliant

NO.	DESCRIPTION	MATERIAL	FINISH, REMARKS
3	NOVASTACK 35-HDP RECEPTACLE ASSEMBLY	-	P/N : 20698-042E-01
2	NOVASTACK 35-HDP PLUG ASSEMBLY	-	P/N : 20697-042E-01
1	VACUUM CAP	LCP	UL94V-0, BLACK

REV.	ECN	BY	DATE	APP.	DESCRIPTION	APPROVAL	DATE	DESCRIPTION	DATE	DESCRIPTION	DATE
3	Z241509	Y.B	2024/10/29	S.S	GENERAL TOLERANCE.						
2	Z230901	Y.B	2023/07/31	Y.H	DWG.	M.Hidaka	2020/07/30				
1	Z230760	Y.B	2023/06/29	Y.H	CHK.	S.Suzuki					
0	Z210856	M.H	2021/07/30		APP.	Y.Hashimoto					

ANGLE	±2°	6 OVER 30 MAX.	±0.3

  

PROJECTION	SERIES No.	CUSTOMER COPY
	R1	

TITLE	SCALE	UNIT	SIZE	SHEET	REV.
NOVASTACK® 35-HDP WITH CAP 2-IN-1	10:1	mm	A3	1/5	3

ITEMS	SPECIFICATION
APPLICABLE CONNECTOR PART No.	21001-042E-01
RATING VOLTAGE	60V AC (PER CONTACT PIN)
RATING AMPERAGE (FOR SIGNAL CONTACT)	0.3A AC/DC (PER CONTACT PIN)/ 12.0A AC/DC (PER CONNECTOR)
RATING AMPERAGE (FOR POWER CONTACT)	2.2A AC/DC (PER CONTACT PIN)/ 8.8A AC/DC (PER CONNECTOR)
OPERATING TEMPERATURE	233~358K(-40°C~+85°C)
OPERATING HUMIDITY	85% MAX.
CONTACT RESISTANCE (FOR SIGNAL CONTACT)	INITIAL : 40mohm MAX. / AFTER TEST : $\Delta$ R 40mohm MAX.
CONTACT RESISTANCE (FOR POWER CONTACT)	INITIAL : 20mohm MAX. / AFTER TEST : $\Delta$ R 20mohm MAX.
CONTACT RESISTANCE (FOR GROUND)	INITIAL : 20mohm MAX. / AFTER TEST : $\Delta$ R 20mohm MAX.
INSULATION RESISTANCE	INITIAL : 1000Mohm MIN. / AFTER TEST : 500Mohm MIN.
DIELECTRIC WITHSTANDING VOLTAGE	AC250V (r.m.s.) 1min
DURABILITY	20 CYCLES
MATING FORCE (INITIAL / AFTER TEST)	150.0N MAX.
UNMATING FORCE (INITIAL / AFTER TEST)	9.2N MIN.
COPLANARITY	0.10 MAX.
PRODUCT SPECIFICATION	PRS-2726
TEST REPORT	TR-21035
PACKING STANDARD	PST-21062
INSTRUCTION MANUAL	HIM-21007
APPEARANCE CRITERIA No.	QLS-A***

ANGLE	$\pm 2^\circ$	6 OVER 30 MAX.	$\pm 0.3$	PROJECTION 	SERIES No. R1	CUSTOMER COPY		
6 MAX.	$\pm 0.2$	30 OVER 120 MAX.	$\pm 0.5$					
GENERAL TOLERANCE.				TITLE NOVASTACK® 35-HDP WITH CAP 2-IN-1	SCALE 10:1	<b>I-PEX</b>		
DWG.	DATE							UNIT mm
CHK.								SIZE A3
APP.								SHEET 2/5
				DWG. No. 21001				

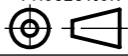

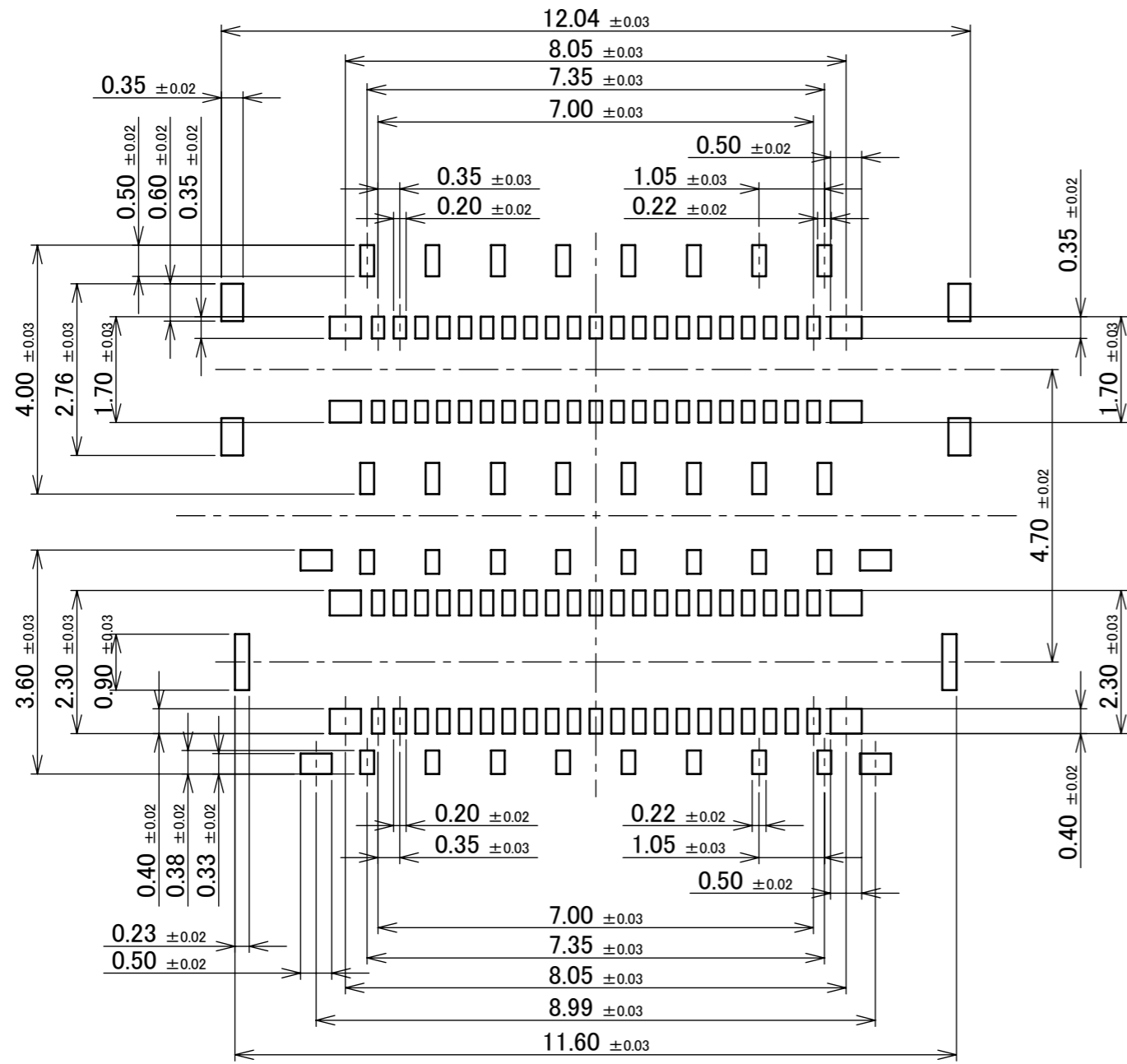
RECOMMENDED PATTERN LAYOUT

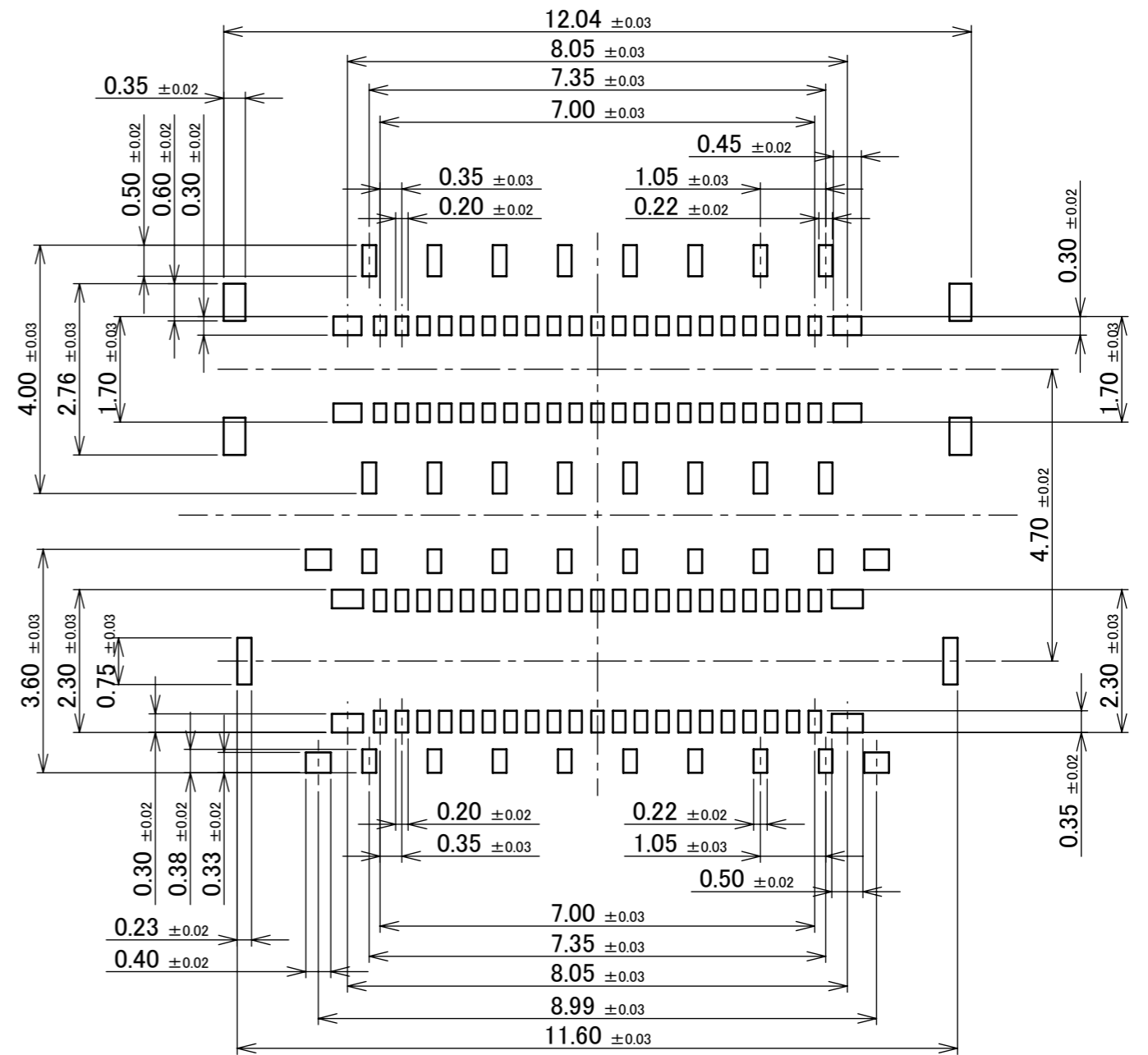

RECOMMENDED METAL MASK LAYOUT  
THICKNESS : t=0.12

ANGLE	±2°	6 OVER 30 MAX.	±0.3	PROJECTION ⊕	SERIES No. R1	CUSTOMER COPY			
	6 MAX.	±0.2	30 OVER 120 MAX.						±0.5
GENERAL TOLERANCE.				TITLE		SCALE	<b>I-PEX</b>		
DWG.	DATE			NOVASTACK® 35-HDP WITH CAP 2-IN-1		10:1			
CHK.						UNIT mm			
APP.				DWG. No.	21001	SIZE A3	SHEET 3/5	REV. 3	

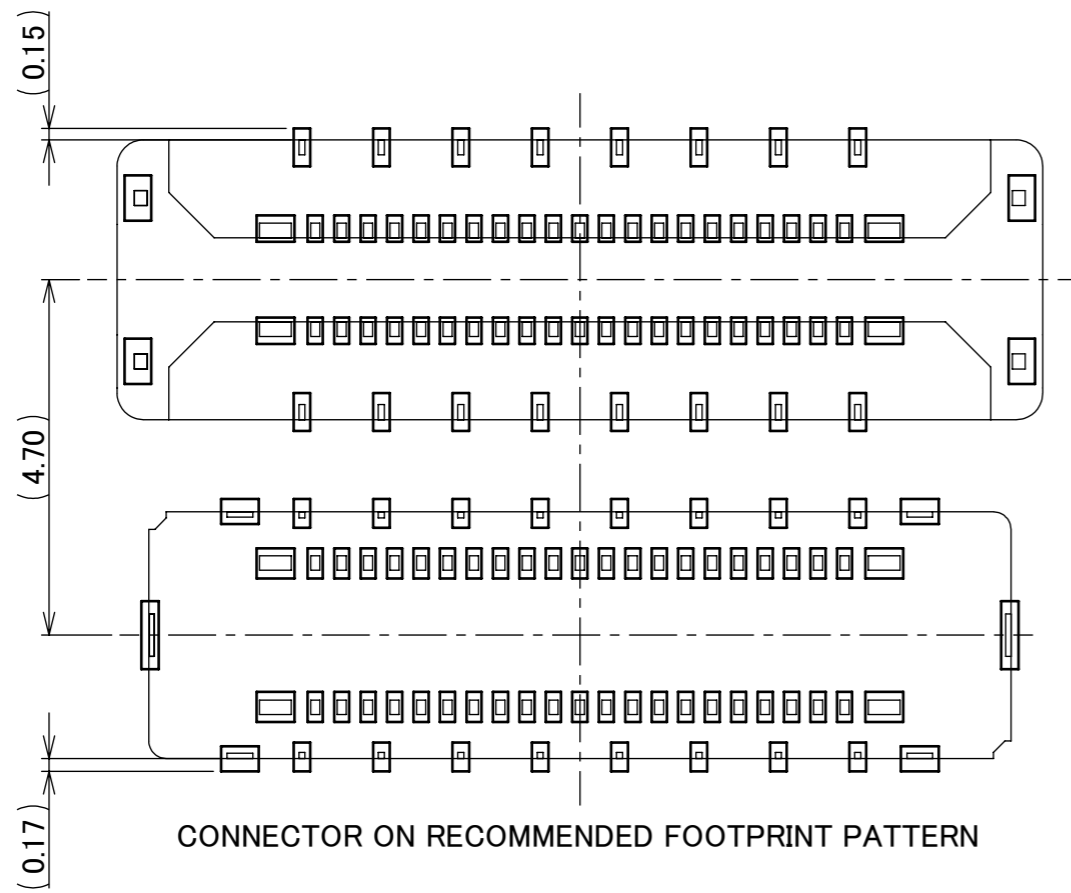

CONNECTOR ON RECOMMENDED FOOTPRINT PATTERN

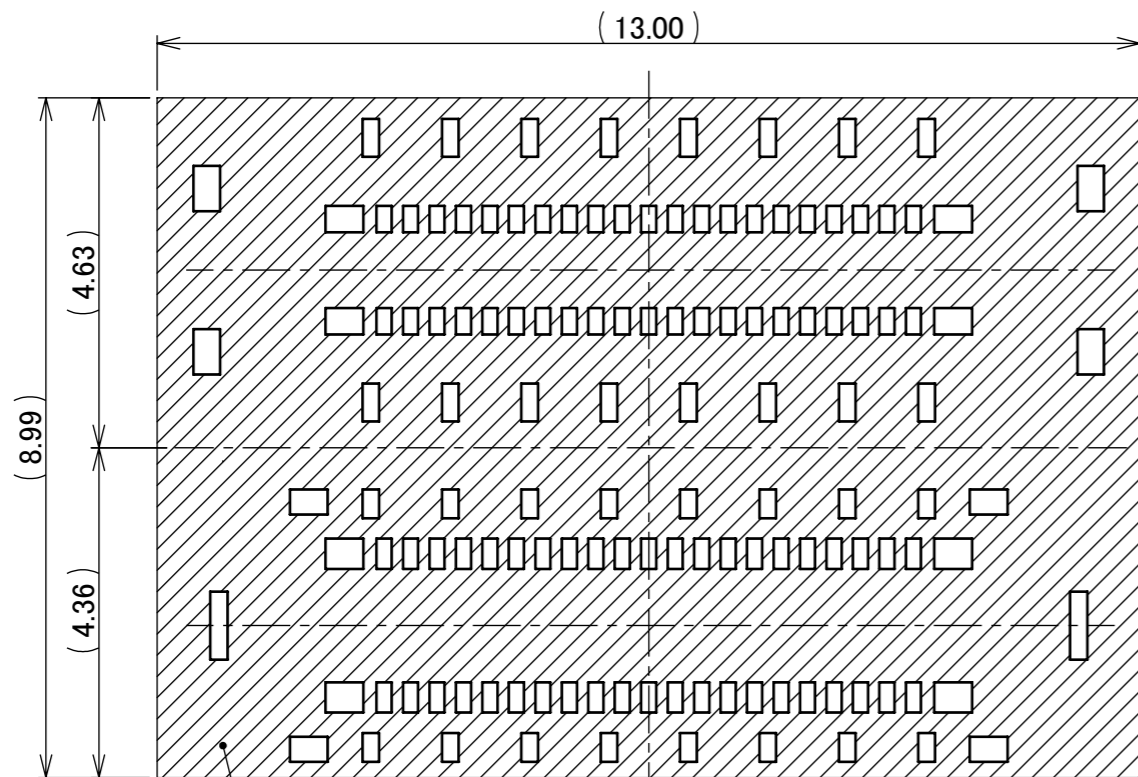

DO NOT MOUNT ANY OTHER COMPONENTS IN THIS AREA.

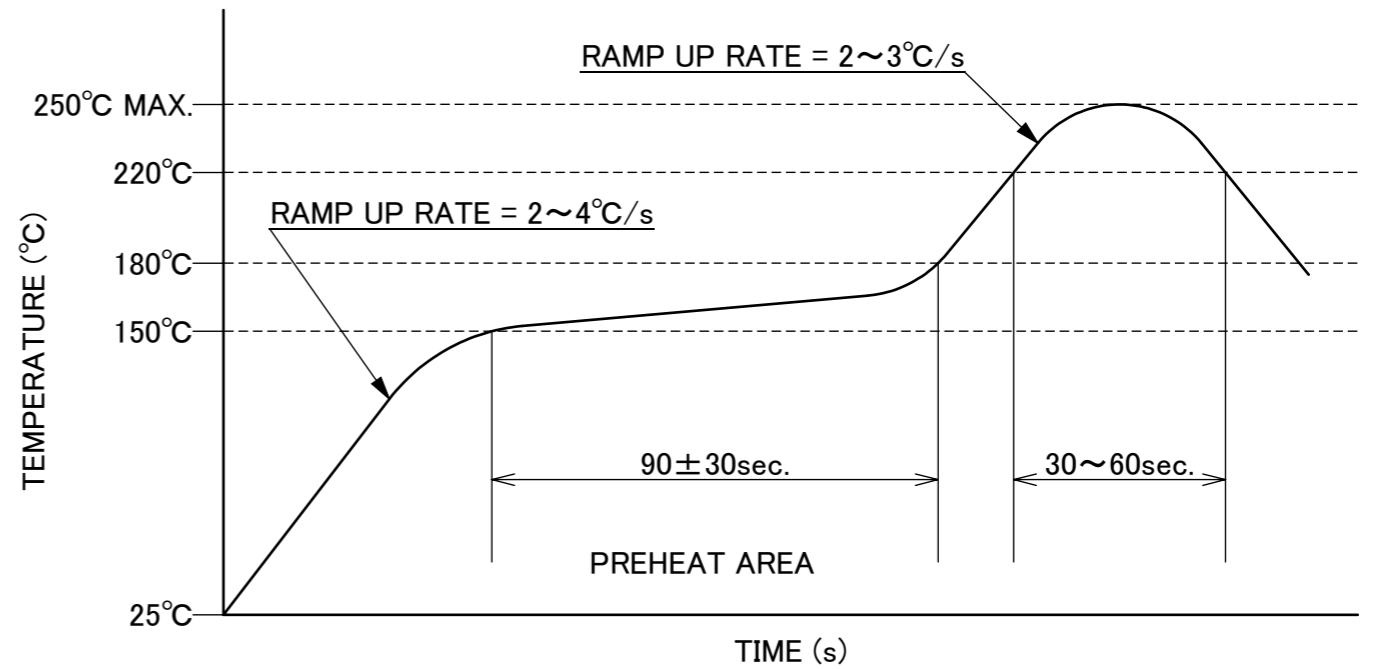

REFLOW TEMPERATURE PROFILE  
SENJU METAL INDUSTRY CO., LTD. : M705-SHF(Sn96.5 Ag3.0 Cu0.5)

ANGLE	±2°	6 OVER 30 MAX.	±0.3	PROJECTION ⊕	SERIES No. R1	CUSTOMER COPY			
6 MAX.	±0.2	30 OVER 120 MAX.	±0.5						
GENERAL TOLERANCE.				TITLE		SCALE	<b>I-PEX</b>		
DWG.	DATE			NOVASTACK® 35-HDP WITH CAP 2-IN-1		10:1			
CHK.						UNIT			
APP.						mm			
				DWG. No.	21001	SIZE	SHEET	REV.	
						A3	4/5	3	

PART NO.	QTY. PER EMBOSS REEL (PIECES / REEL)	QTY. PER PACKING CARTON
21001-042E-01	3,000 / REEL	3,000 × 5 REELS = 15,000

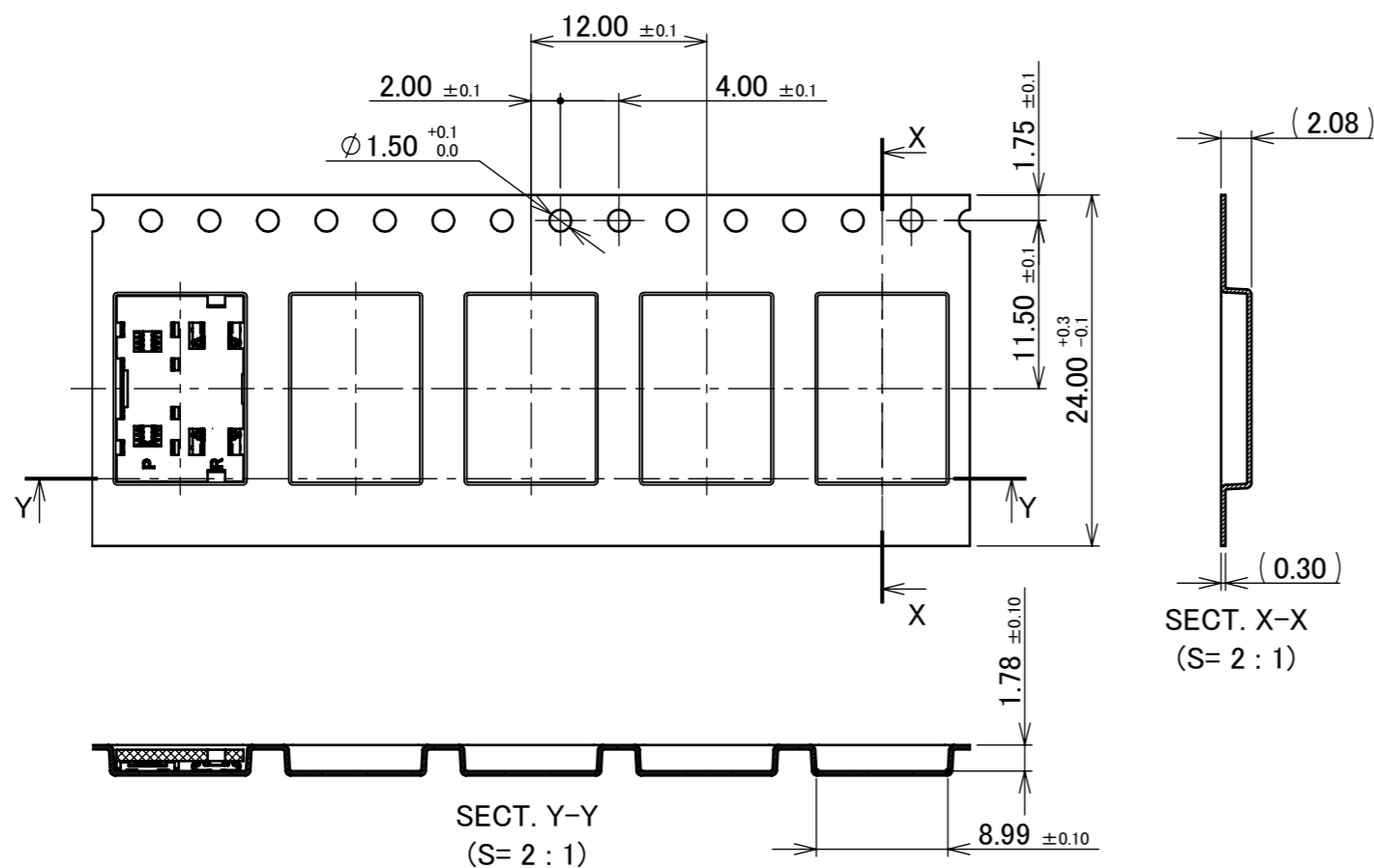
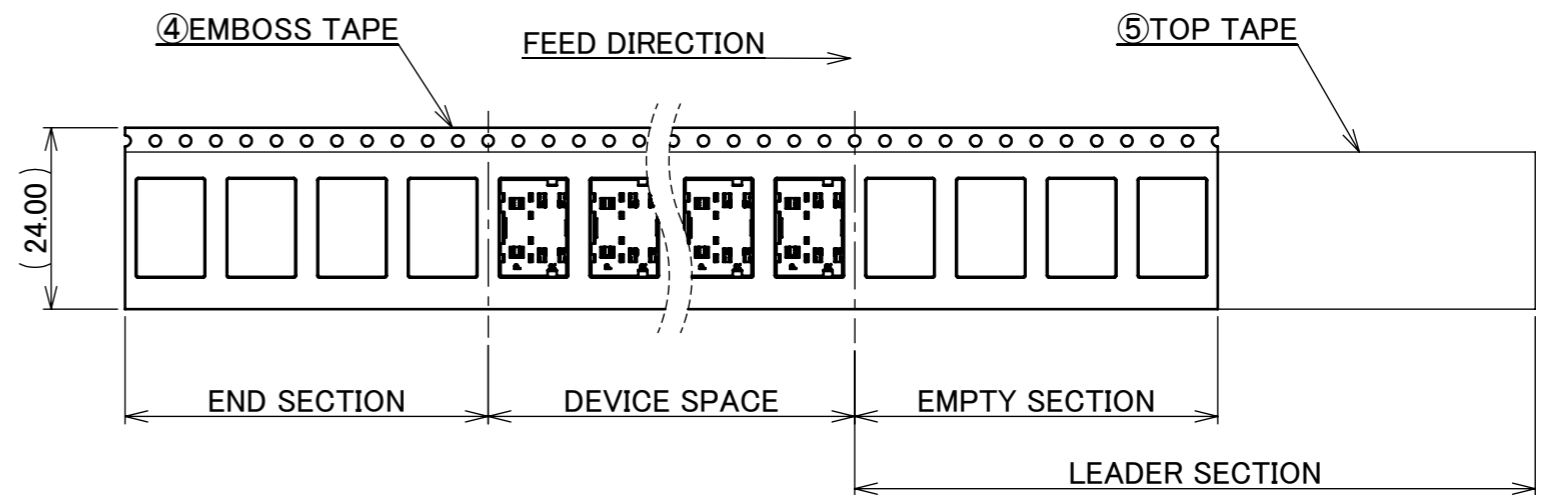
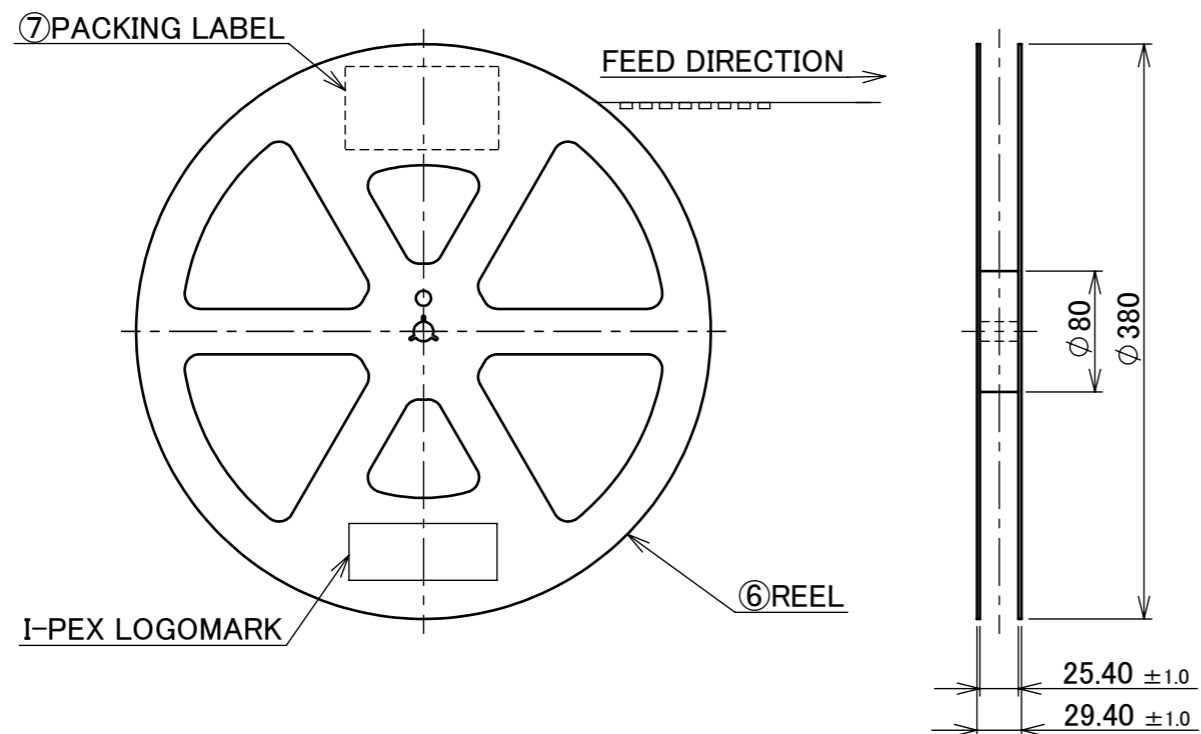

NOTES.

- TAPING SPECIFICATION FOLLOWS JIS C 0806 (IEC 60286-3)
- MAKE EMPTY SECTION OF LEADER AND END ON EACH END OF THE TAPE.
- TOP TAPE SHALL NOT STICK OUT FROM EMBOSS TAPE.
- TOP TAPE SHALL NOT COVER FEED HOLE.

NO.	DESCRIPTION	MATERIAL	FINISH, REMARKS
7	PACKING LABEL	-	-
6	REEL	PS	ANTI-STATIC TYPE BLACK
5	TOP TAPE	PET t=0.062 TRANSPARENCY	ANTI-STATIC TYPE
4	EMBOSS TAPE	PS t=0.3 TRANSPARENCY	ANTI-STATIC TYPE

ANGLE	$\pm 2^\circ$	6 OVER 30 MAX.	$\pm 0.3$	PROJECTION ①	SERIES No. R1	CUSTOMER COPY
6 MAX.	$\pm 0.2$	30 OVER 120 MAX.	$\pm 0.5$			
GENERAL TOLERANCE.				TITLE NOVASTACK® 35-HDP WITH CAP 2-IN-1	SCALE 1:X	UNIT mm
DWG.	DATE					
CHK.						
APP.						
DWG. No. 21001				SIZE A3	SHEET 5/5	REV. 3