

Recommended P/N 20698-0**E-01#

PART No.	SIGNAL POS.	POWER POS.	A	B	C	D
20698-028E-01	28P	4P	8.95	6.54	5.60	4.55
20698-034E-01	34P	4P	10.00	7.59	6.65	5.60
20698-042E-01#	42P	4P	11.40	8.99	8.05	7.00
20698-056E-01#	56P	4P	13.85	11.44	10.50	9.45
20698-062E-01#	62P	4P	14.90	12.49	11.55	10.50

20698-0**E-01M

WITHOUT : 10,000 pcs/REEL
WITH : 5,000 pcs/REEL

Pos.



Halogen Free



RoHS Compliant

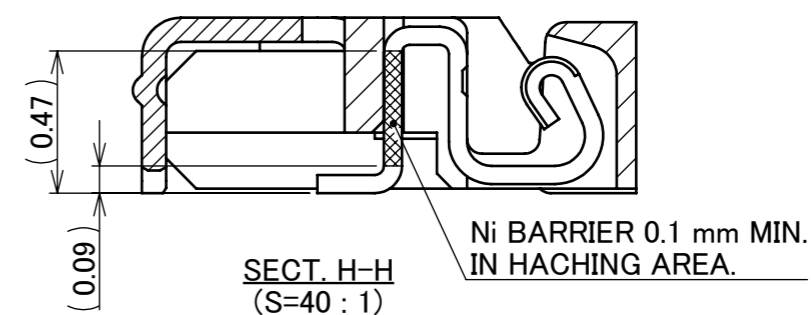
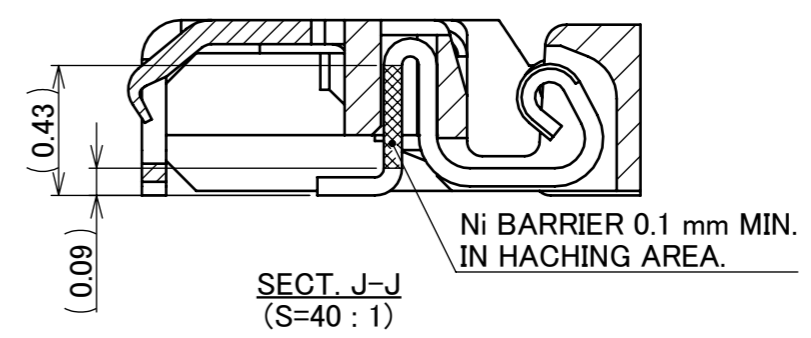
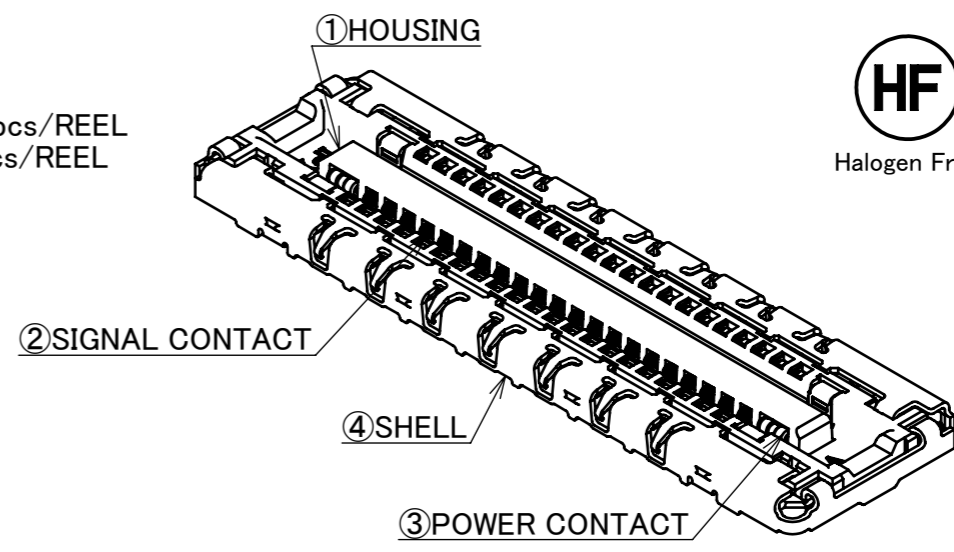
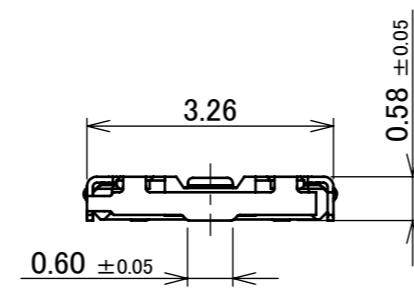
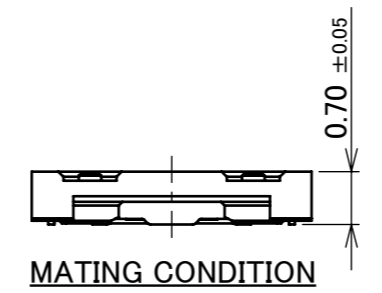
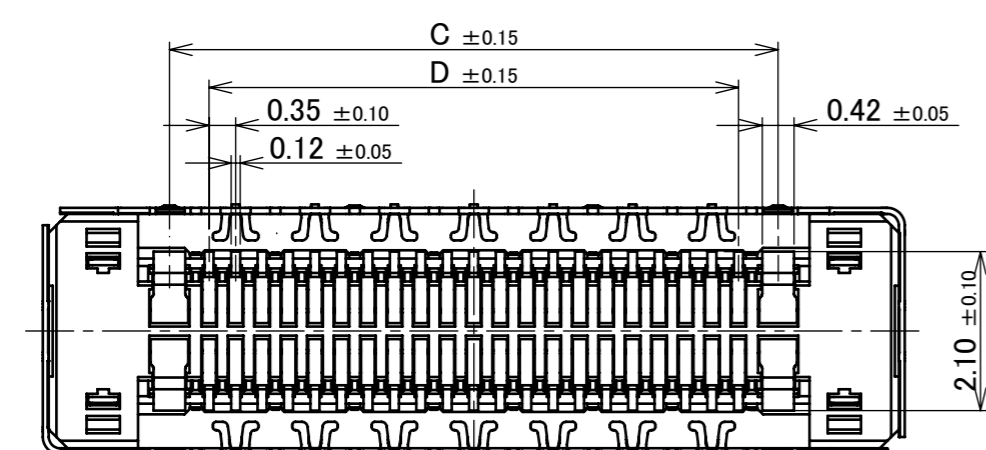
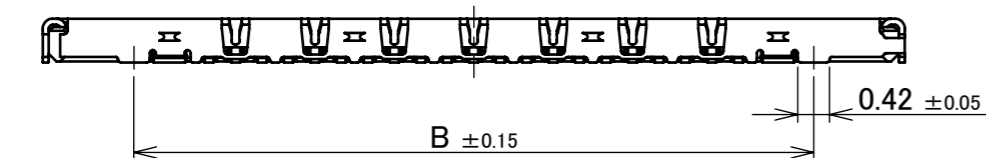
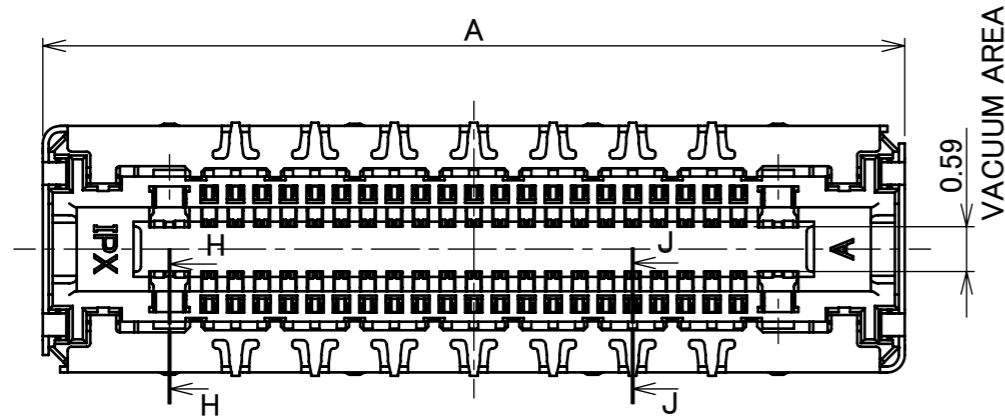

NO.	DISCRIPTION	MATERIAL	FINISH , REMARKS
4	SHELL	PHOSPHOR BRONZE	ALL OVER Ni 1.27 μ m MIN. Au 0.01 μ m MIN.
3	POWER CONTACT	CORSON ALLOY	ALL OVER Ni 1.27 μ m MIN. CONTACT PART Au 0.05 μ m MIN. SOLDERING PART Au 0.02 μ m MIN.
2	SIGNAL CONTACT	CORSON ALLOY	ALL OVER Ni 1.27 μ m MIN. CONTACT PART Au 0.10 μ m MIN. SOLDERING PART Au 0.02 μ m MIN.
1	HOUSING	LCP	UL94V-0, BLACK

REV.	ECN	BY	DATE	APP.	APP.	DATE	APP.	PROJECTION	SERIES No.	TITLE	SCALE	SHEET	REV.
9	Z220191	Y.I	Mar./04/'22	Y.H	ANGLE	±2°	6 OVER 30 MAX.	±0.3		R2	10:1	A3	9
8	Z211370	M.H	Nov./09/'21	Y.H	6 MAX.	±0.2	30 OVER 120 MAX.	±0.5					
7	Z200541	Y.B	May/26/'20	T.Y	GENERAL TOLERANCE.				NOVASTACK® 35-HDP RECEPTACLE ASS'Y	mm	1/8	9	
6	Z180895	R.H	July/09/'18	TAK	DWG.	T.Kurachi	DATE						2016/01/13
5	Z180170	T.K	Feb./09/'18	Y.S	CHK.								
4	Z171521	M.N	Dec./27/'17	J.T	APP.	J.Tateishi							
REVISION RECORD								DWG. No.	20698				

PART No.	SIGNAL POS.	POWER POS.
20698-028E-01	28P	4P
20698-034E-01	34P	4P
20698-042E-01#	42P	4P
20698-056E-01#	56P	4P
20698-062E-01#	62P	4P

20698-0**E-01M

WITHOUT : 10,000 pcs/REEL
WITH : 5,000 pcs/REEL

Pos.

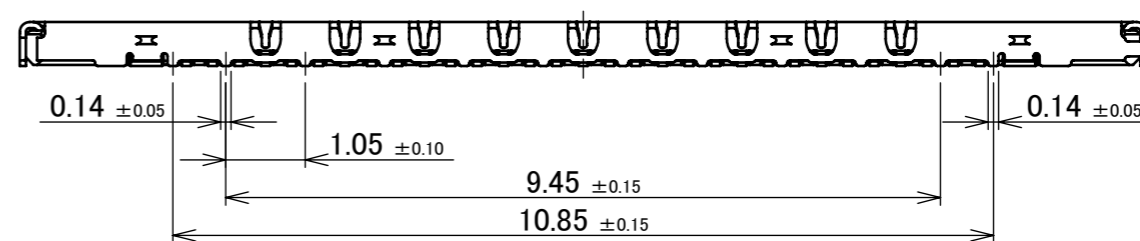
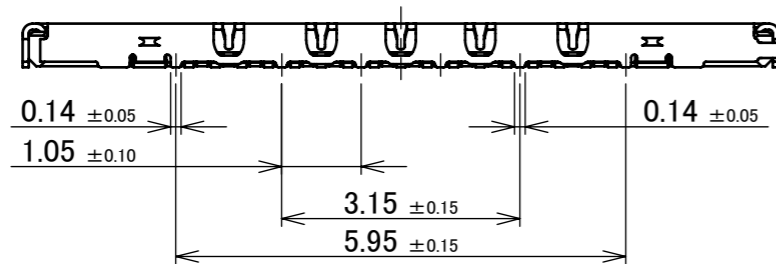
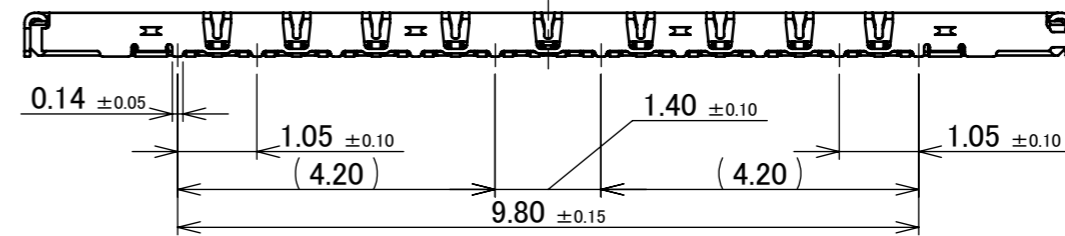
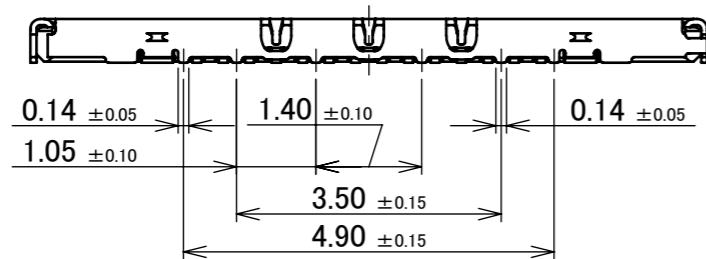
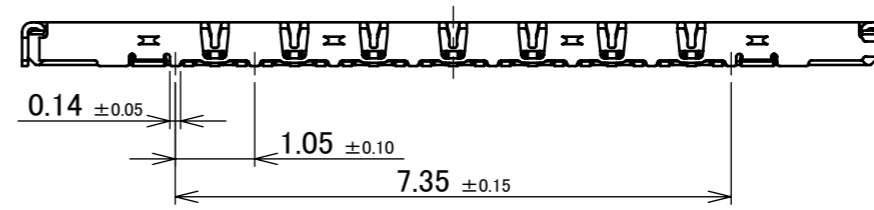

ANGLE	±2°	6 OVER 30 MAX.	±0.3	PROJECTION ⊕	SERIES No. R2	CUSTOMER COPY		
6 MAX.	±0.2	30 OVER 120 MAX.	±0.5					
GENERAL TOLERANCE.				TITLE NOVASTACK® 35-HDP RECEPTACLE ASS'Y		SCALE	I-PEX	
DWG.	DATE		10:1					
CHK.			UNIT					
APP.			mm					
				DWG. No.	20698	SIZE	SHEET	REV.
						A3	2/8	9

ITEMS	SPECIFICATION
APPLICABLE CONNECTOR PART No.	20697-0**E-01*
RATING VOLTAGE	60V AC (PER CONTACT PIN)
RATING AMPERAGE (FOR SIGNAL CONTACT)	0.3A AC/DC (PER CONTACT PIN)/ 12.0A AC/DC(TOTAL)
RATING AMPERAGE (FOR POWER CONTACT)	2.2A AC/DC (PER CONTACT PIN)/ 8.8A AC/DC(TOTAL)
OPERATING TEMPERATURE	233~358K(-40°C~+85°C)
OPERATING HUMIDITY	85% MAX.(NON-CONDENSING)
CONTACT RESISTANCE (FOR SIGNAL CONTACT)	INITIAL : 40mohm MAX. / AFTER TEST : \triangle 40mohm MAX.
CONTACT RESISTANCE (FOR POWER CONTACT)	INITIAL : 20mohm MAX. / AFTER TEST : \triangle 20mohm MAX.
CONTACT RESISTANCE (FOR GROUND)	INITIAL : 20mohm MAX. / AFTER TEST : \triangle 20mohm MAX.
INSULATION RESISTANCE	INITIAL : 1,000Mohm MIN. / AFTER TEST : 500Mohm MIN.
DIELECTRIC WITHSTANDING VOLTAGE	AC250V 1min
DURABILITY	30 CYCLES
MATING FORCE (INITIAL)	1.0N \times n + 4.0N MAX.
UNMATING FORCE (AFTER TEST)	0.1N \times n + 0.4N MIN.
COPLANARITY	0.08 MAX.
PRODUCT SPECIFICATION	PRS-2187
TEST REPORT	TR-16014
PACKING STANDARD	PST-15084 (10K/REEL) PST-16126 (5K/REEL)
INSTRUCTION MANUAL	HIM-15020
APPEARANCE CRITERIA No.	QLS-A***

ANGLE	$\pm 2^\circ$	6 OVER 30 MAX.	± 0.3	PROJECTION 	SERIES No. R2	CUSTOMER COPY	
6 MAX.	± 0.2	30 OVER 120 MAX.	± 0.5				
GENERAL TOLERANCE.				TITLE NOVASTACK® 35-HDP RECEPTACLE ASS'Y	SCALE	I-PEX	
DWG.	DATE						
CHK.							
APP.							
DWG. No.	20698			UNIT mm	SIZE A3	SHEET 3/8	REV. 9

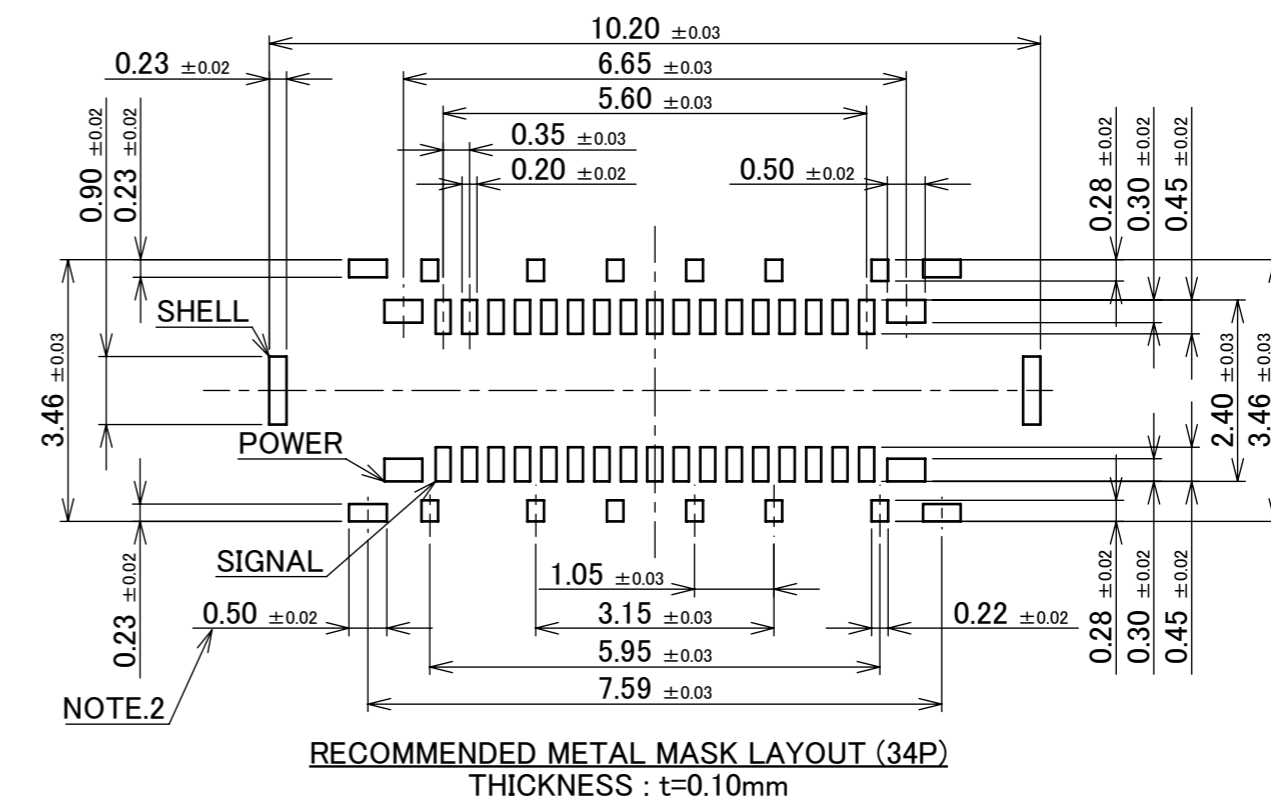
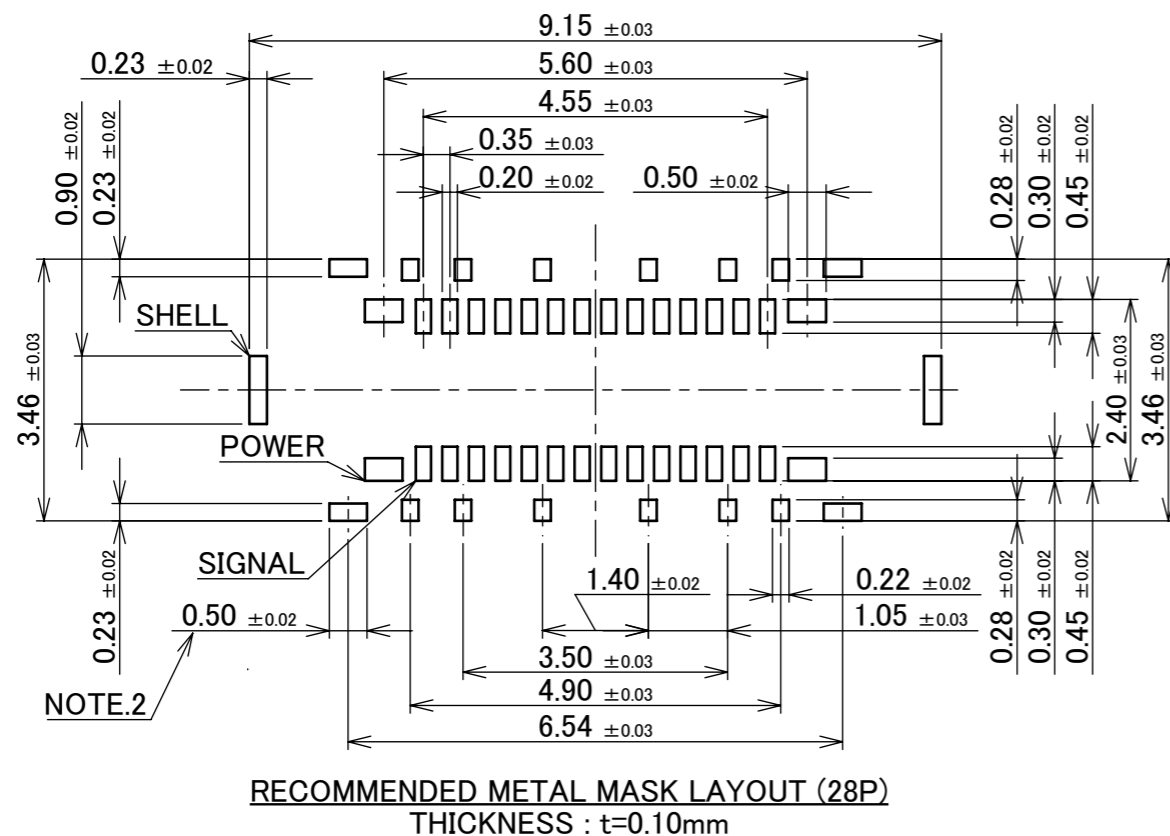
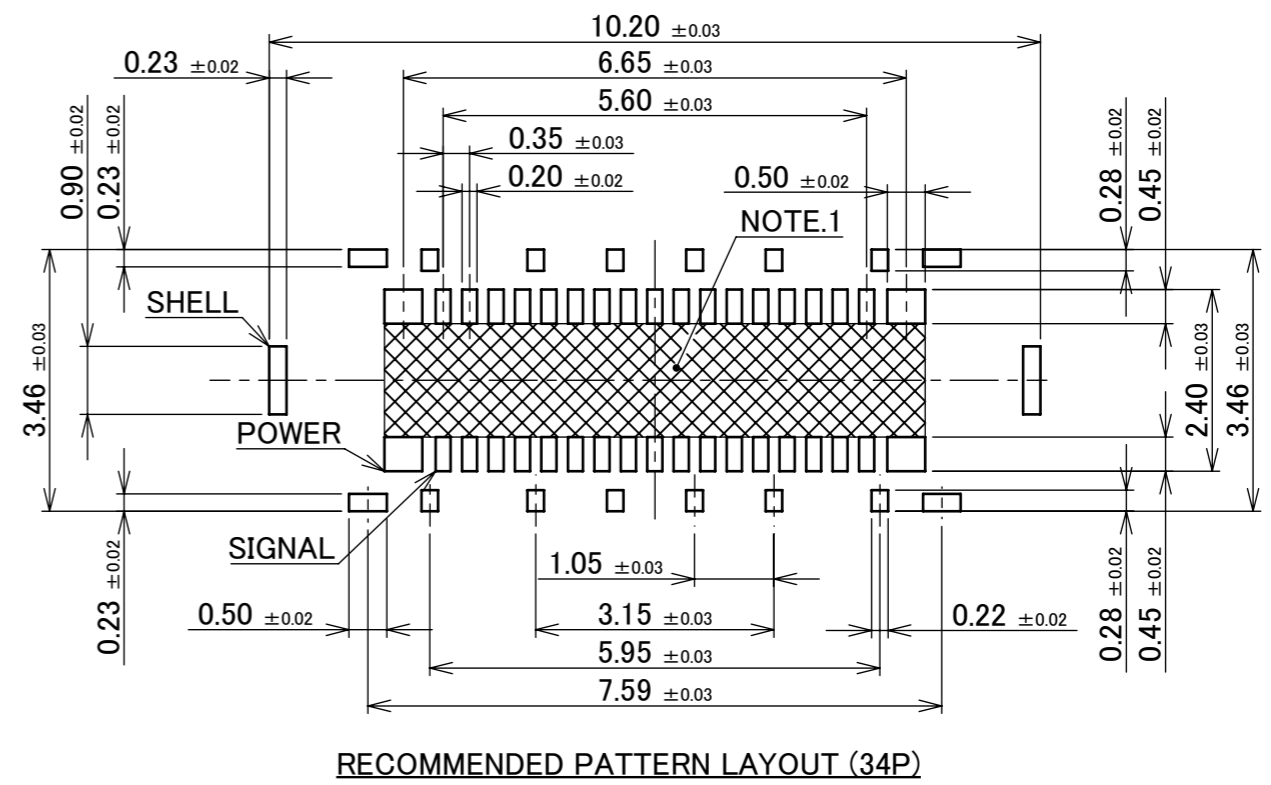
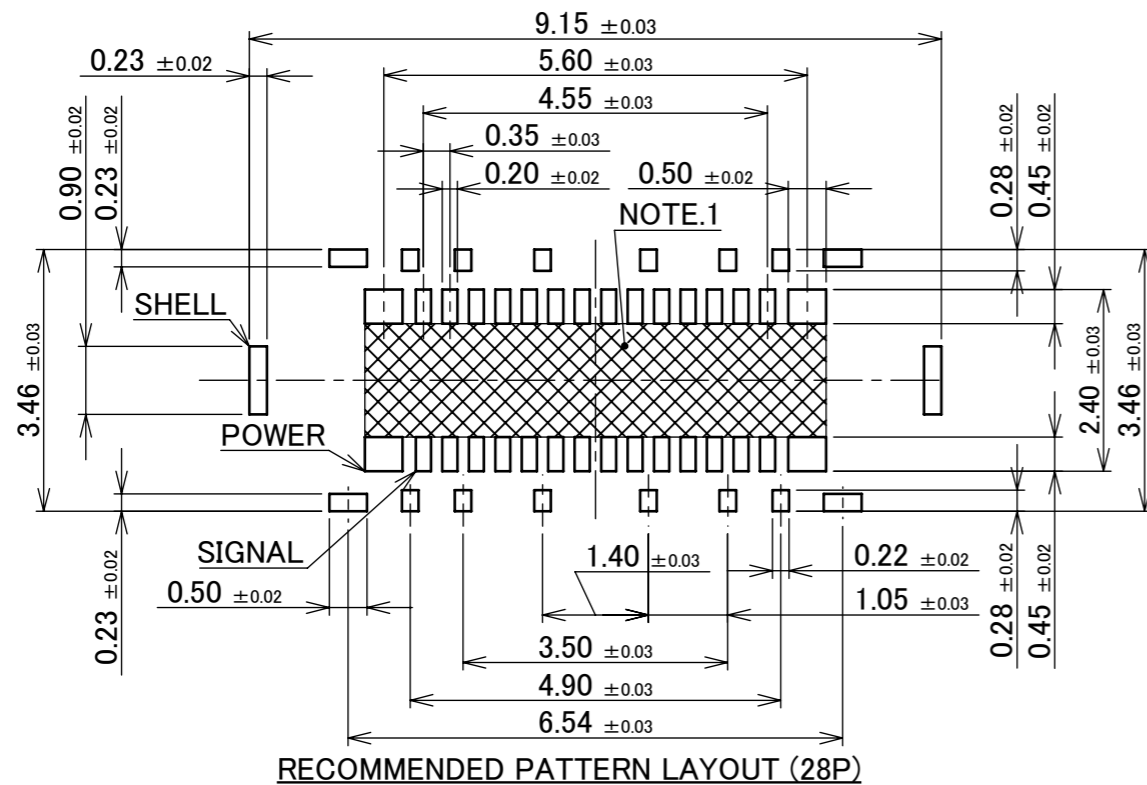

- NOTES.
1. SOLDER RESIST SHALL BE COATED IN CASE OF RUNNING TRACES ON THIS FOOT PRINT PATTERN PROHIBITION AREA.
 2. WHEN THE THICKNESS OF THE METAL MASK IS 0.12 mm, PLEASE SET IT TO 0.41 mm.

ANGLE	±2°	6 OVER 30 MAX.	±0.3	PROJECTION ⊕	SERIES No. R2	CUSTOMER COPY		
	6 MAX.	±0.2	30 OVER 120 MAX.			±0.5	SCALE	I-PEX
GENERAL TOLERANCE.				TITLE NOVASTACK® 35-HDP RECEPTACLE ASS'Y	10:1	SHEET	REV.	
DWG.	DATE				mm			
CHK.					SIZE			
APP.				DWG. No.	20698	A3		

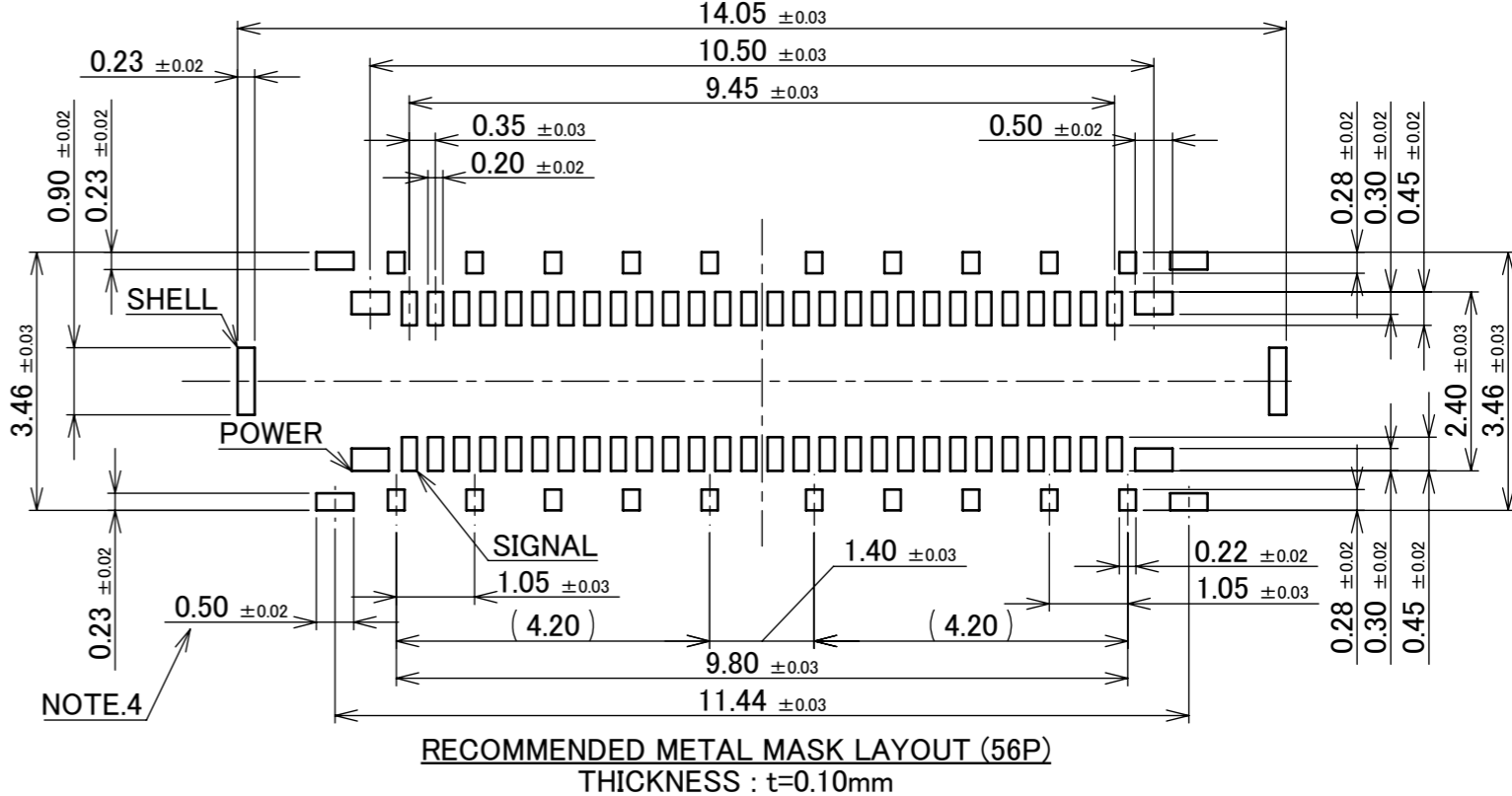
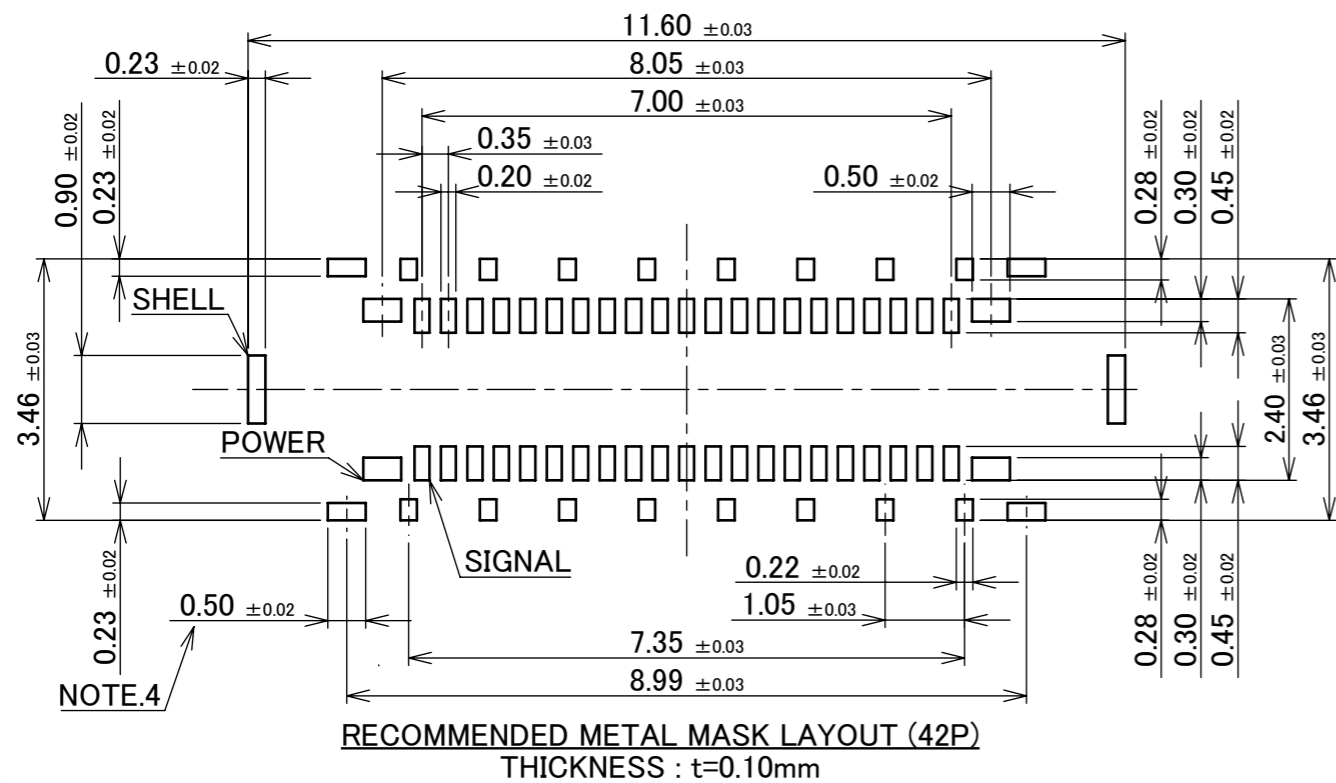
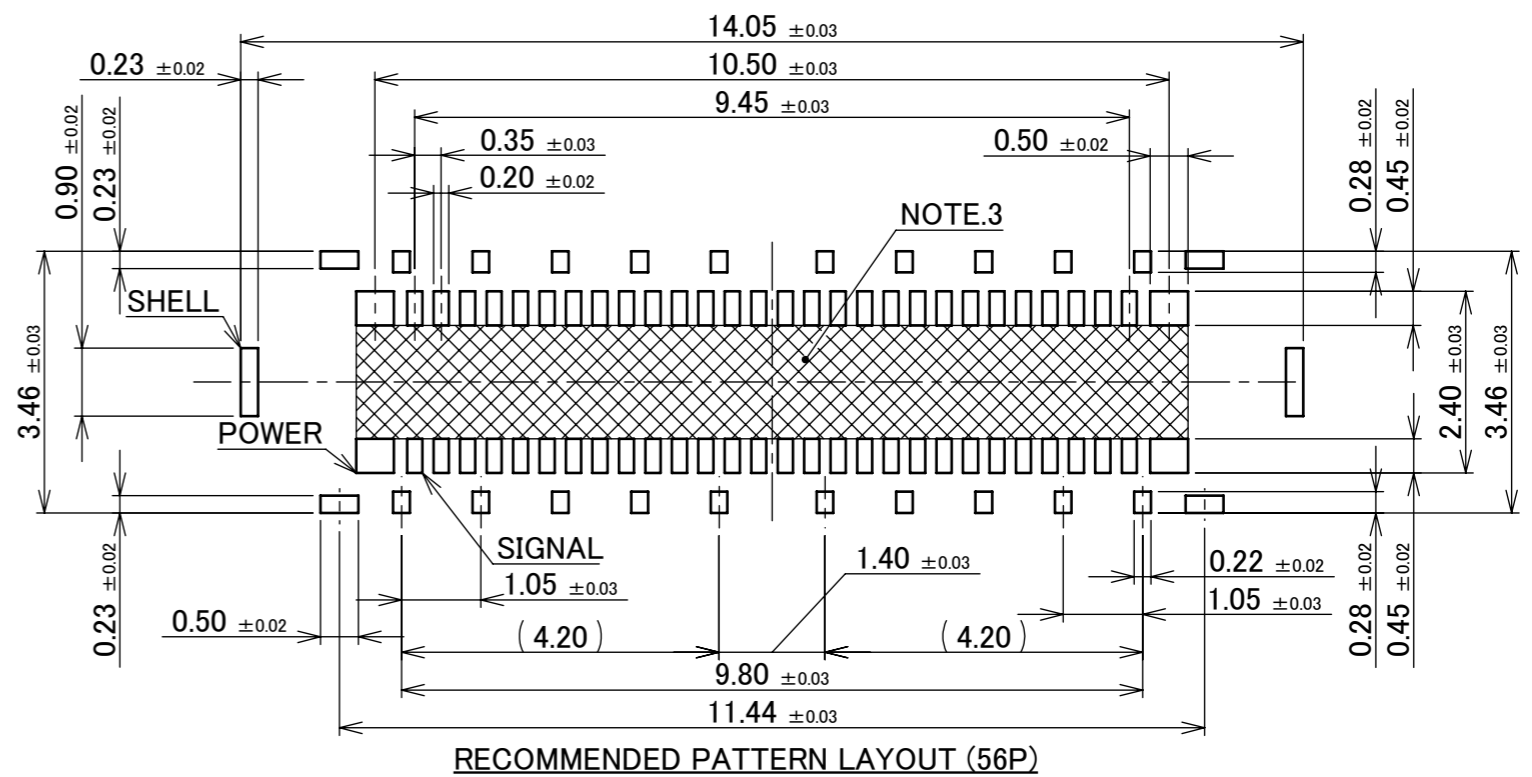
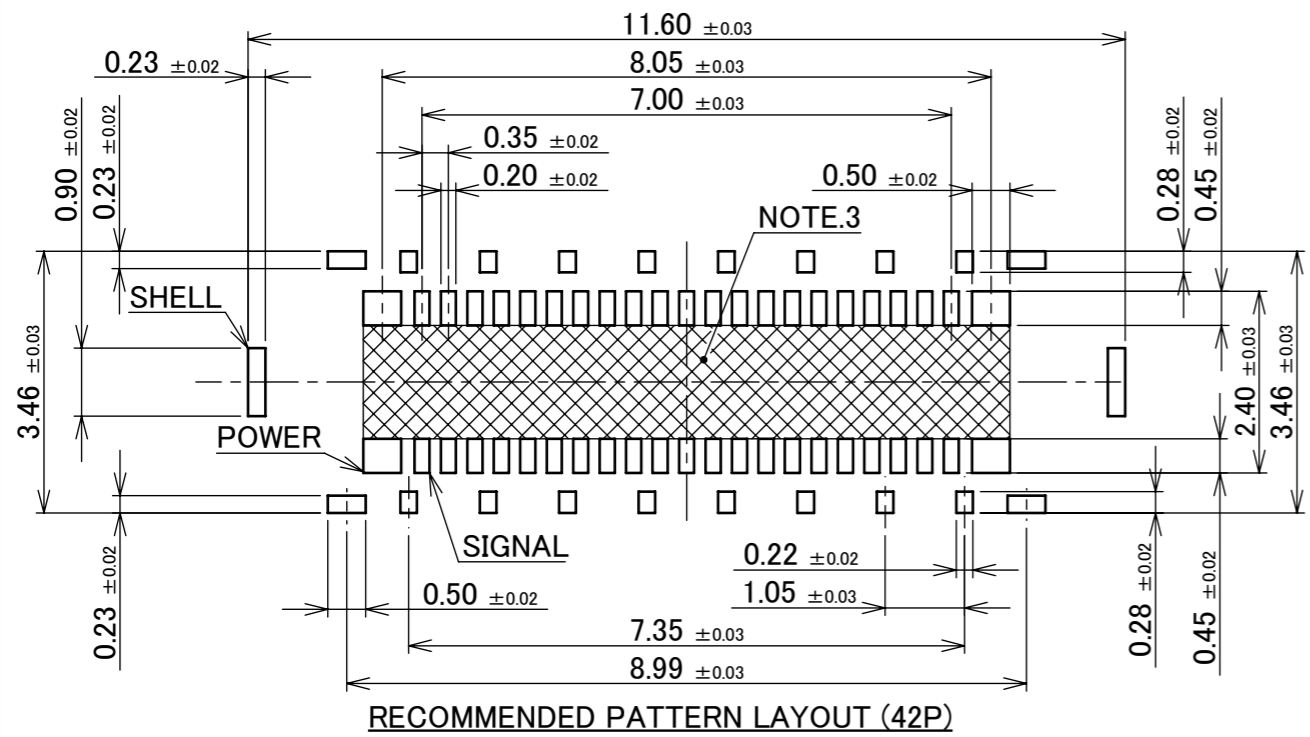

- NOTES.
3. SOLDER RESIST SHALL BE COATED IN CASE OF RUNNING TRACES ON THIS FOOT PRINT PATTERNPROHIBITION AREA.
 4. WHEN THE THICKNESS OF THE METAL MASK IS 0.12 mm, PLEASE SET IT TO 0.41 mm.

ANGLE	±2°	6 OVER 30 MAX.	±0.3	PROJECTION	SERIES No.	CUSTOMER COPY	
	6 MAX.	±0.2	30 OVER 120 MAX.	±0.5	R2		
GENERAL TOLERANCE.				TITLE	SCALE	I-PEX	
DWG.	DATE			NOVASTACK® 35-HDP RECEPTACLE ASS'Y	10:1		
CHK.					mm		
APP.				DWG. No.	20698	SIZE	SHEET
						A3	5/8
							REV.
							9

PART No.	SIGNAL POS.	POWER POS.	E
20698-028E-01	28P	4P	9.15
20698-034E-01	34P	4P	10.20
20698-042E-01#	42P	4P	11.60
20698-056E-01#	56P	4P	14.05
20698-062E-01#	62P	4P	15.10

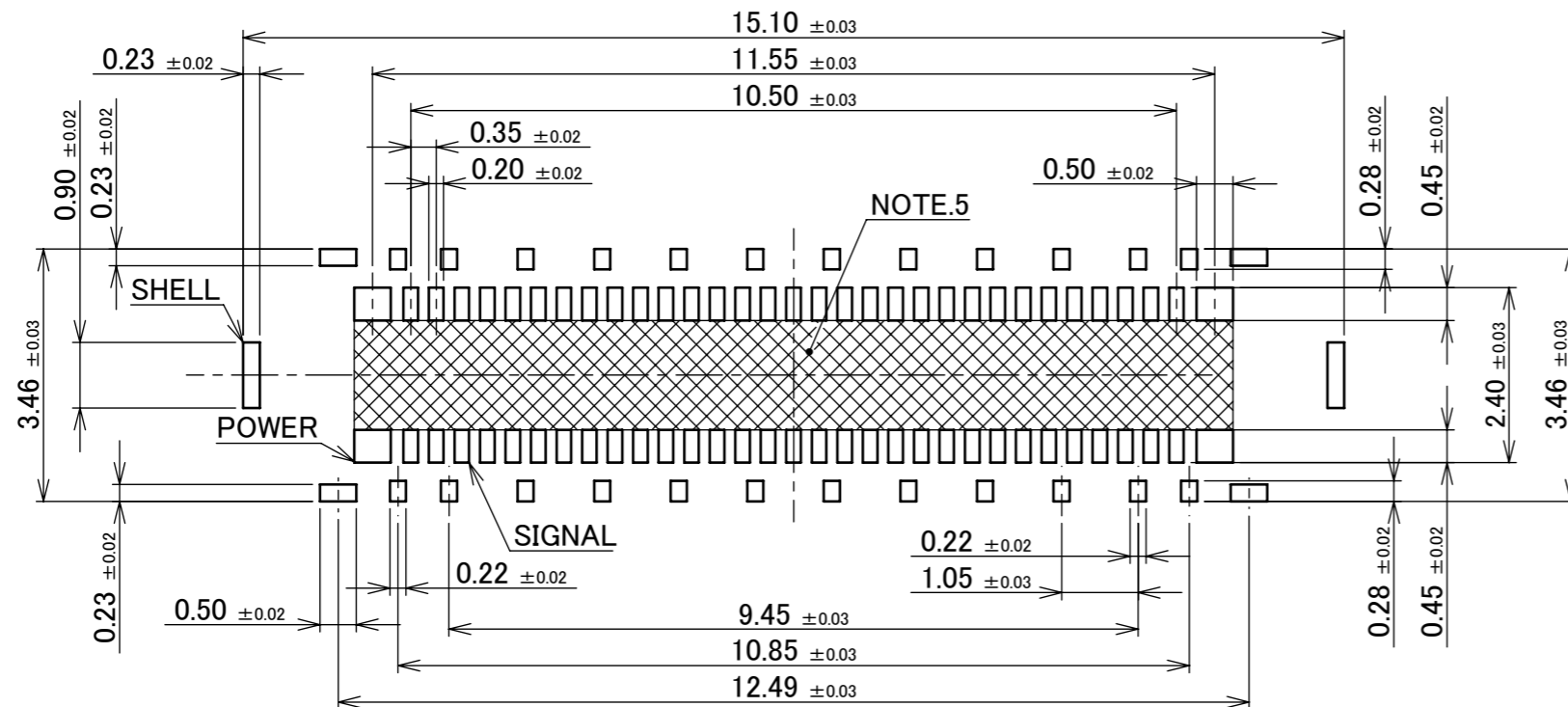

RECOMMENDED PATTERN LAYOUT (62P)

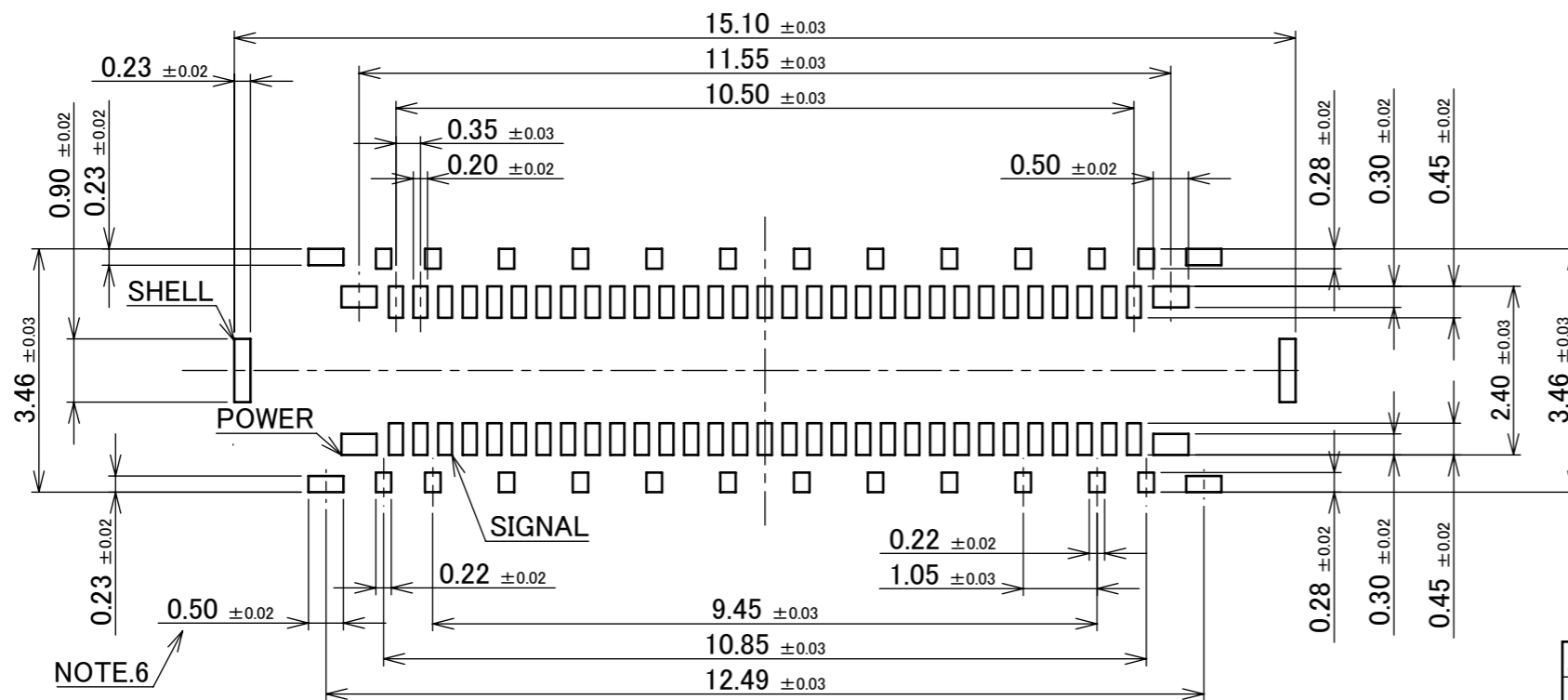

RECOMMENDED METAL MASK LAYOUT (62P)

THICKNESS : t=0.10 mm

NOTES.

- SOLDER RESIST SHALL BE COATED IN CASE OF RUNNING TRACES ON THIS FOOT PRINT PATTERNPROHIBITION AREA.
- WHEN THE THICKNESS OF THE METAL MASK IS 0.12 mm, PLEASE SET IT TO 0.41 mm.
- THIS AREA CANNOT MOUNT ANOTHER COMPONENTS.

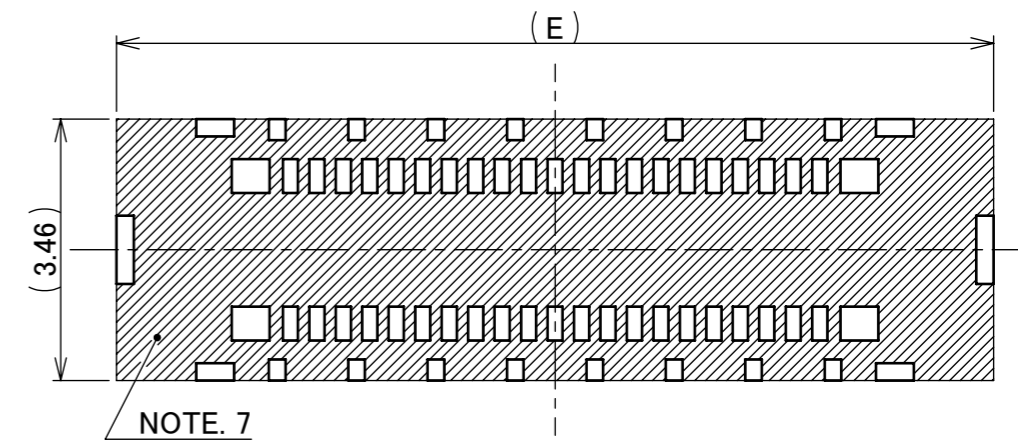

ANGLE	±2°	6 OVER 30 MAX.	±0.3	PROJECTION	SERIES No.	CUSTOMER COPY	
	6 MAX.	±0.2	30 OVER 120 MAX.	±0.5	R2		
GENERAL TOLERANCE.				TITLE	SCALE	I-PEX	
DWG.	DATE			NOVASTACK® 35-HDP RECEPTACLE ASS'Y	10:1		
CHK.				DWG. No.	SIZE	SHEET	REV.
APP.				20698	A3	6/8	9

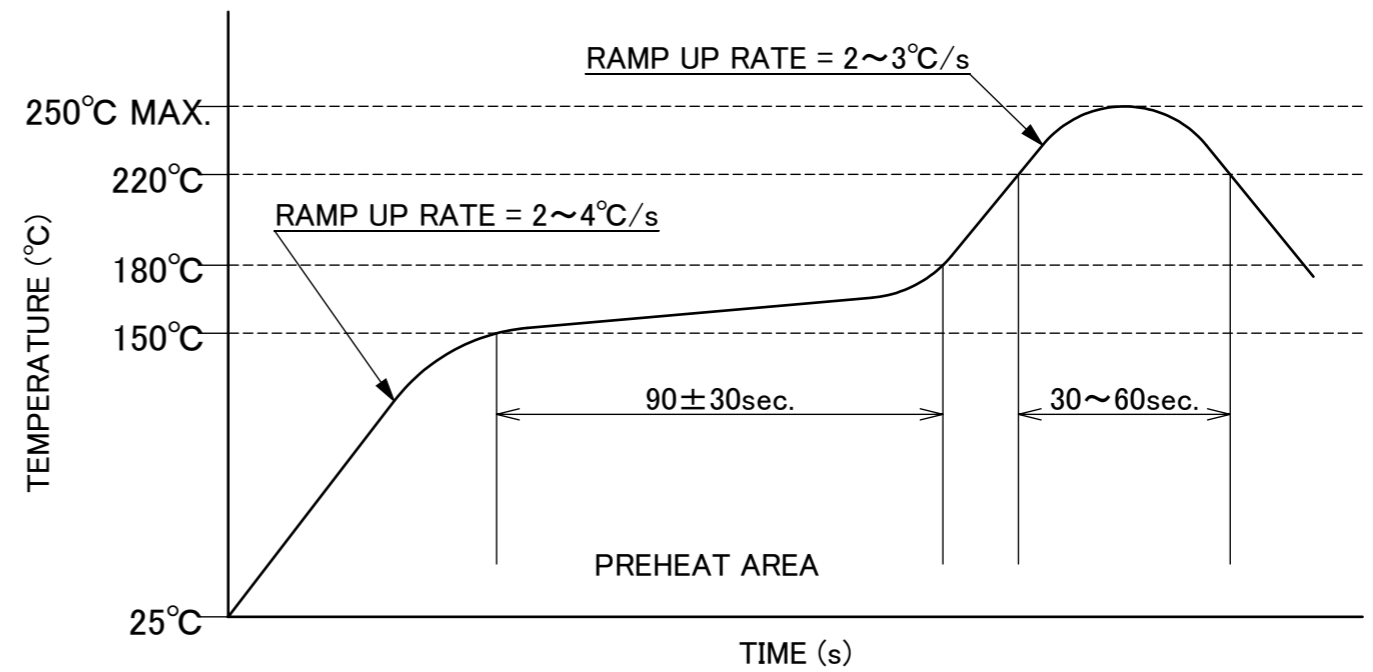
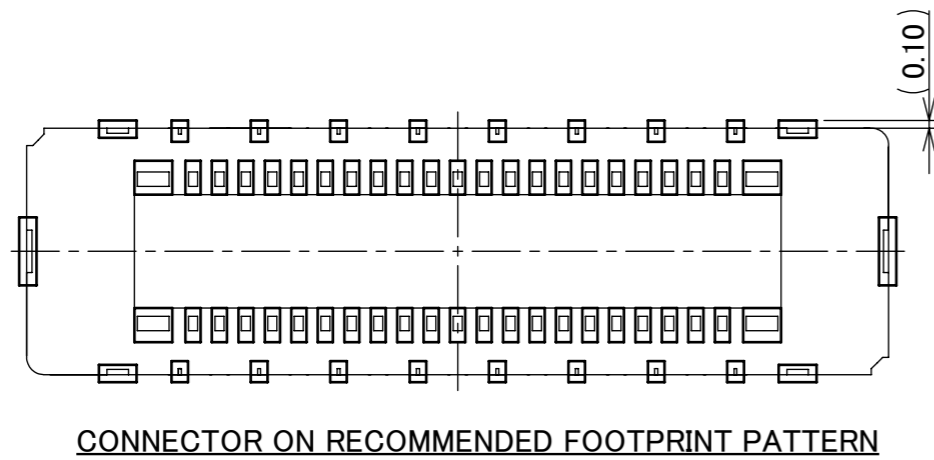

REFLOW TEMPERATURE PROFILE
 SENJU METAL INDUSTRY CO., LTD. : M705-SHF(Sn96.5 Ag3.0 Cu0.5)

ANGLE	±2°	6 OVER 30 MAX.	±0.3	PROJECTION 	SERIES No. R2	CUSTOMER COPY		
6 MAX.	±0.2	30 OVER 120 MAX.	±0.5					
GENERAL TOLERANCE.				TITLE NOVASTACK® 35-HDP RECEPTACLE ASS'Y	SCALE 10:1	I-PEX		
DWG.	DATE							
CHK.								
APP.								
				DWG. No.	20698	SIZE A3	SHEET 7/8	REV. 9

PART NO.	Pos.	QTY. PER EMBOSS REEL (PIECES / REEL)	QTY. PER PACKING CARTON
20698-0**E-01	28P	10,000 / REEL	10,000 × 5 REELS = 50,000
	34P		
	42P		
	56P		
	62P		
20698-0**E-01M	42P	5,000 / REEL	5,000 × 5 REELS = 25,000
	56P		
	62P		

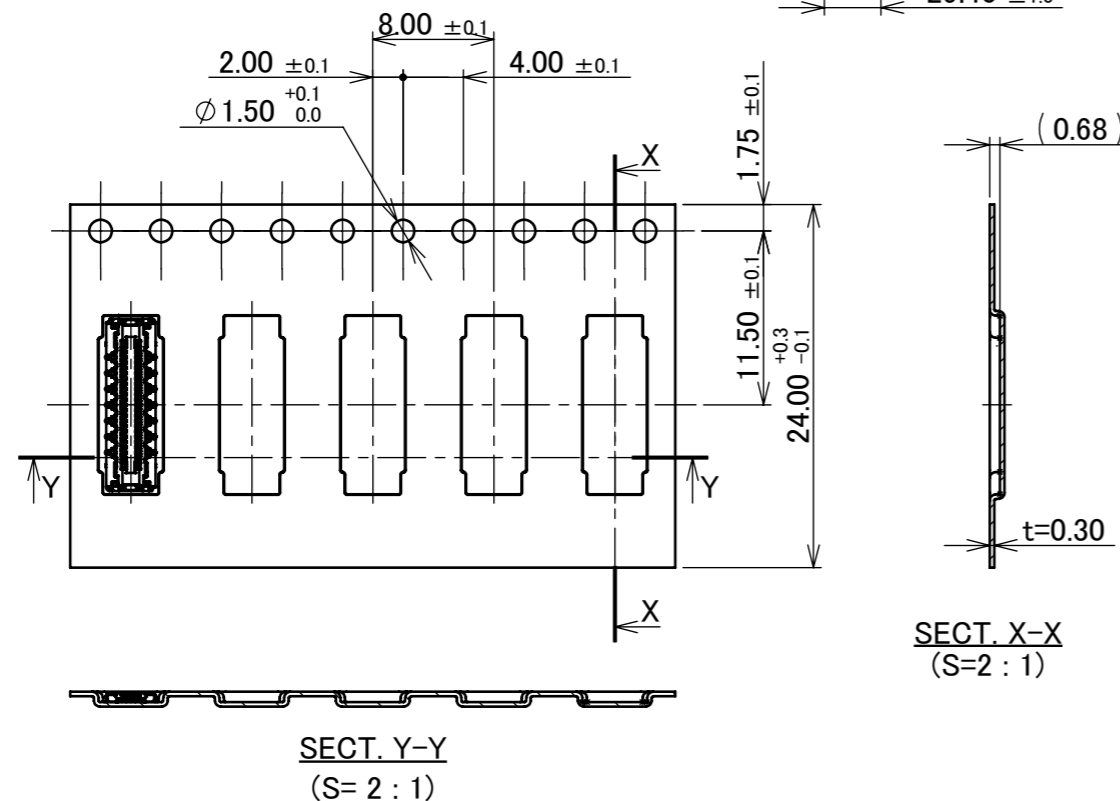
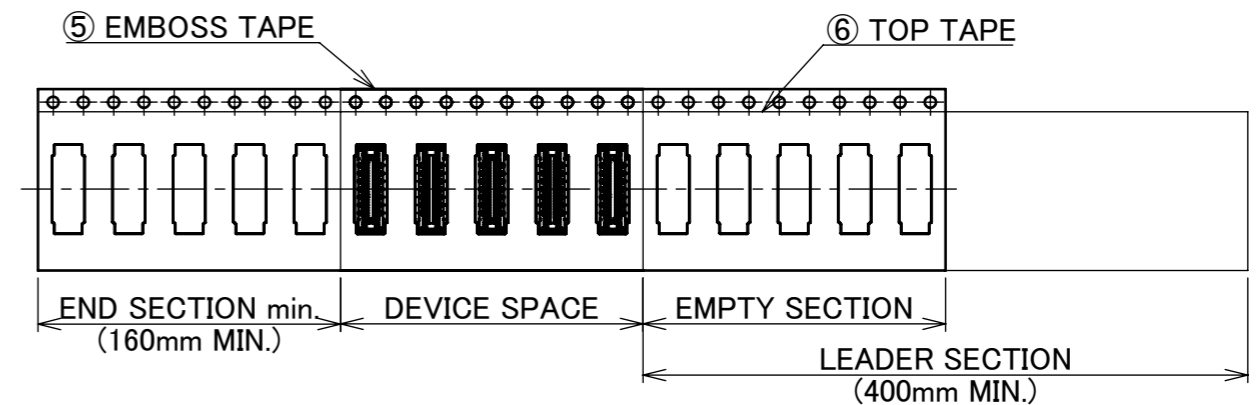
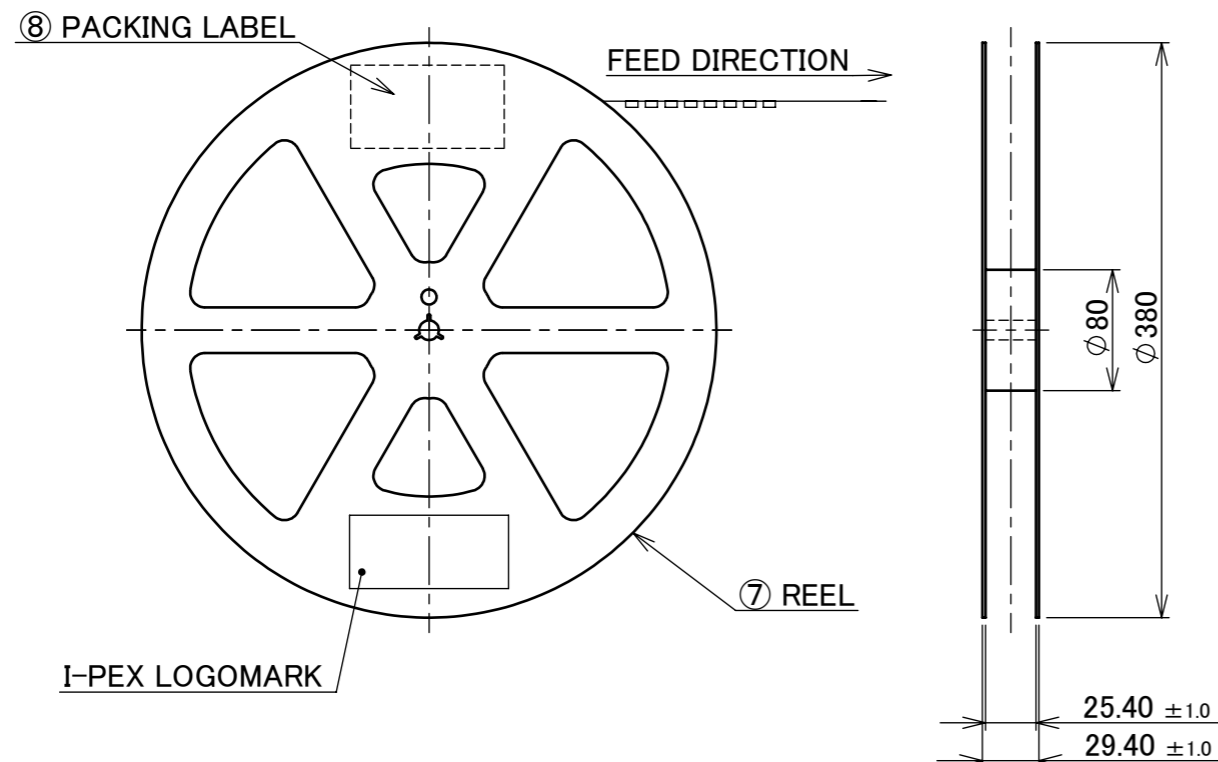

NOTES.

8. TAPING SPECIFICATION FOLLOWS JIS C 0806 (IEC 60286-3).
9. MAKE EMPTY SECTION OF LEADER AND END ON EACH END OF THE TAPE.
10. TOP TAPE SHALL NOT STICK OUT FROM EMBOSS TAPE.
11. TOP TAPE SHALL NOT COVER FEED HOLE.

NO.	DESCRIPTION	MATERIAL	FINISH , REMARKS
8	PACKING LABEL	-	-
7	REEL	PS	ANTI-STATIC TYPE BLACK
6	TOP TAPE	PET t=0.062 TRANSPARENCY	ANTI-STATIC TYPE
5	EMBOSS TAPE	PS TRANSPARENCY	ANTI-STATIC TYPE

ANGLE	±2°	6 OVER 30 MAX.	±0.3	PROJECTION	SERIES No.	CUSTOMER COPY			
6 MAX.	±0.2	30 OVER 120 MAX.	±0.5		R2				
GENERAL TOLERANCE.				TITLE	NOVASTACK® 35-HDP RECEPTACLE ASS'Y		SCALE	X:1	
DWG.	DATE					UNIT	mm		
CHK.						SIZE	SHEET	8/8	REV.
APP.				DWG. No.	20698	A3		9	