

PART NO.	Pos.
20865-010E-03	10

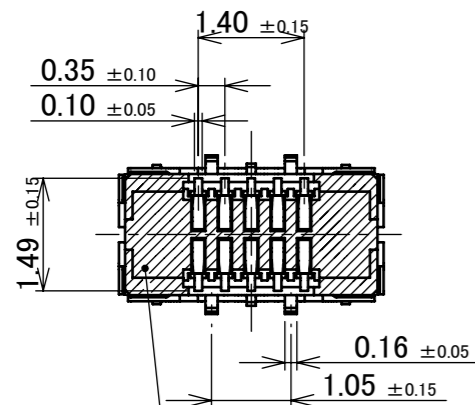

There is a possibility of dent shape in the bottom surface of HOUSING.

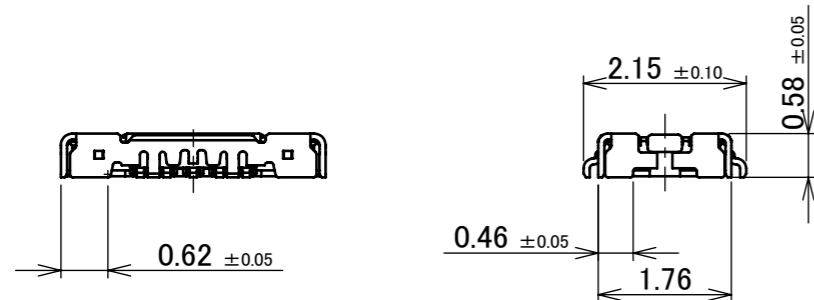
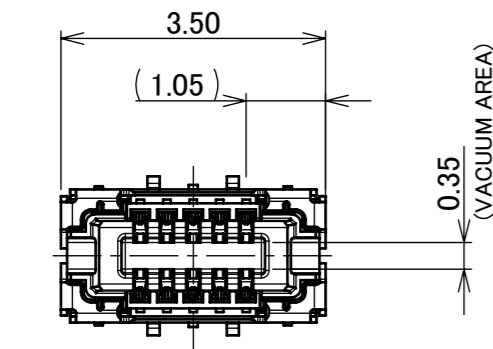
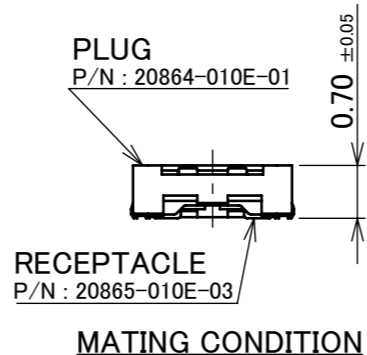
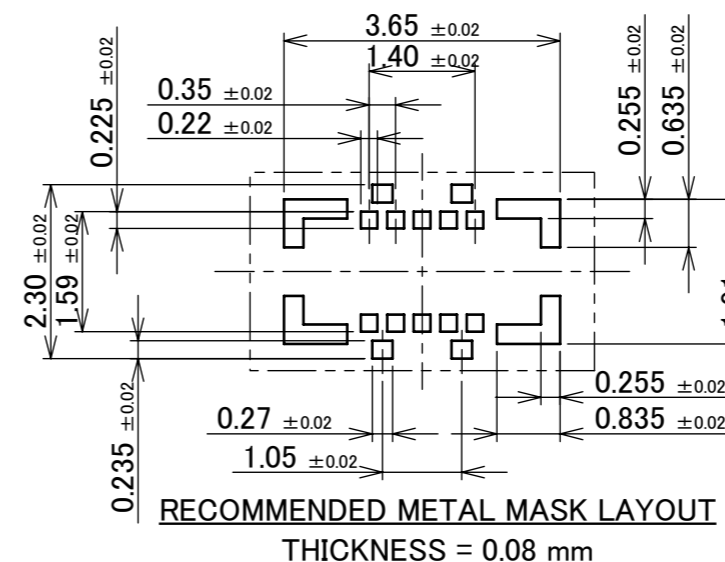
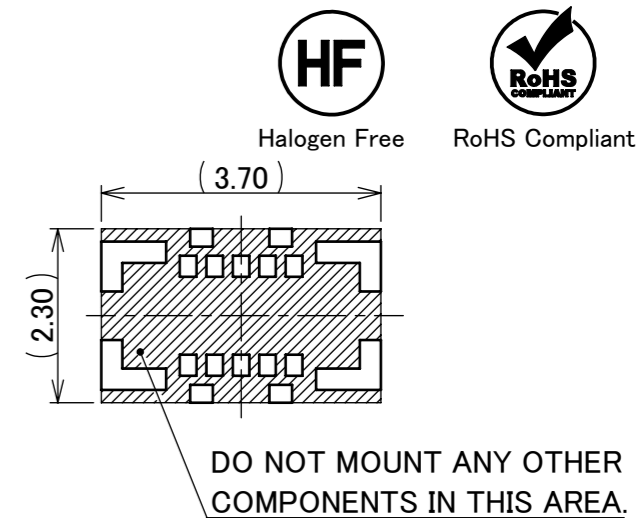
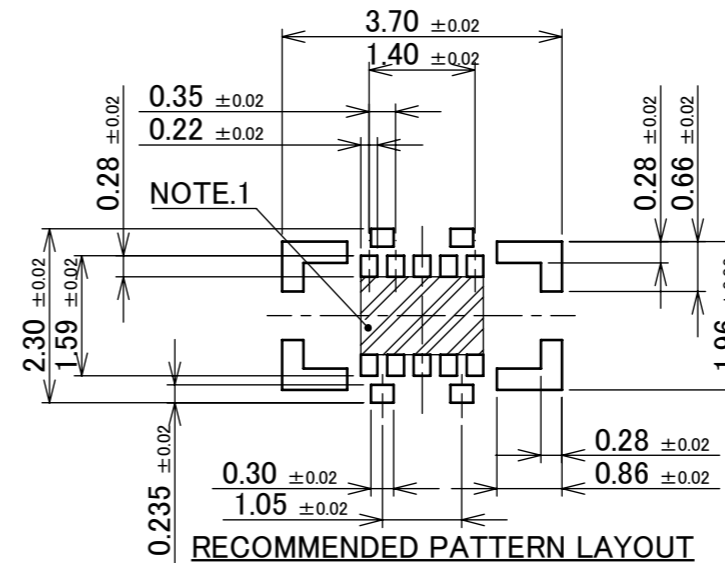
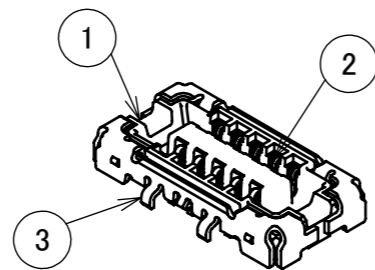

NOTES.

1. FOOT PRINT PATTERN PROHIBITION AREA :
SOLDER RESIST MUST BE APPLIED TO THIS HATCHED AREA
IF SURFACE TRACES ARE ROUNDED.

3	SHELL	COPPER ALLOY	SOLDERING PART Au 0.01 μm MIN. OVER Ni 1.27 μm MIN.	
2	CONTACT	COPPER ALLOY	CONTACT PART Au 0.05 μm MIN. OVER Ni 1.27 μm MIN. SOLDERING PART Au 0.01 μm MIN. OVER Ni 1.27 μm MIN.	
1	HOUSING	LCP	UL94V-0 BLACK	
NO.	DISCRIPTION	MATERIAL	FINISH, REMARKS	
9	Z220201	TSU 2022/02/25 Y.H	ANGLE ±2°	6 OVER 30 MAX. ±0.3
8	Z201019	M.H Oct./02/'20 Y.H	6 MAX. ±0.2	30 OVER 120 MAX. ±0.5
7	Z191631	Tad Dec./16/'19 Y.S	GENERAL TOLERANCE.	
6	Z190899	Tad Jul./09/'19 Y.S	DWG. T.Hirakawa	DATE 2018/01/12
5	Z190692	Tad May/24/'19 Y.S	CHK.	
4	Z190598	Tad May./07/'19 TAK	APP.	
REV.	ECN	BY	DATE	APP.
REVISION RECORD				
			K.Yotsutani	2018/01/12
		DWG. No.	20865	
		TITLE	NOVASTACK® 35-HDN RECEPTACLE ASS'Y	
		PROJECTION	SERIES No. R3	
		SCALE	10:1	
		UNIT	mm	
		SIZE	A3	
		SHEET	1/6	
		REV.	9	
		CUSTOMER COPY		
		I-PEX		

PART NO.	Pos.
20865-020E-03	20

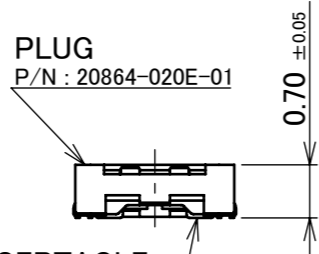

RECEPTACLE
P/N: 20865-020E-03
MATING CONDITION

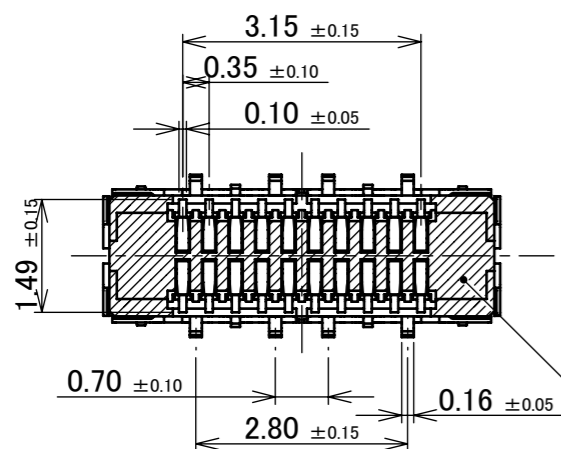
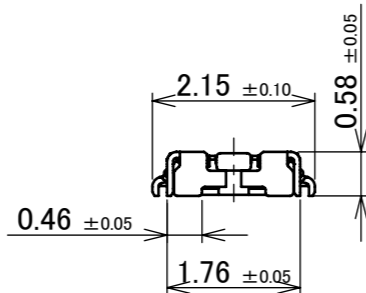
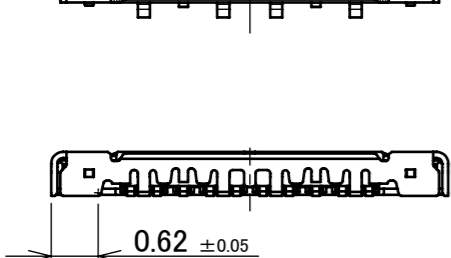
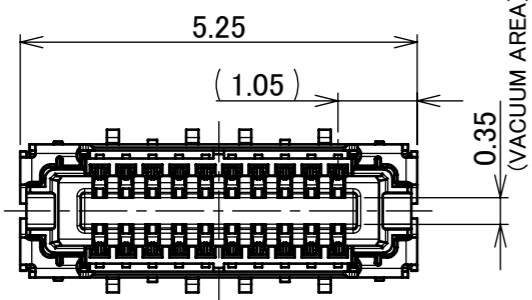

There is a possibility of dent shape in the bottom surface of HOUSING.

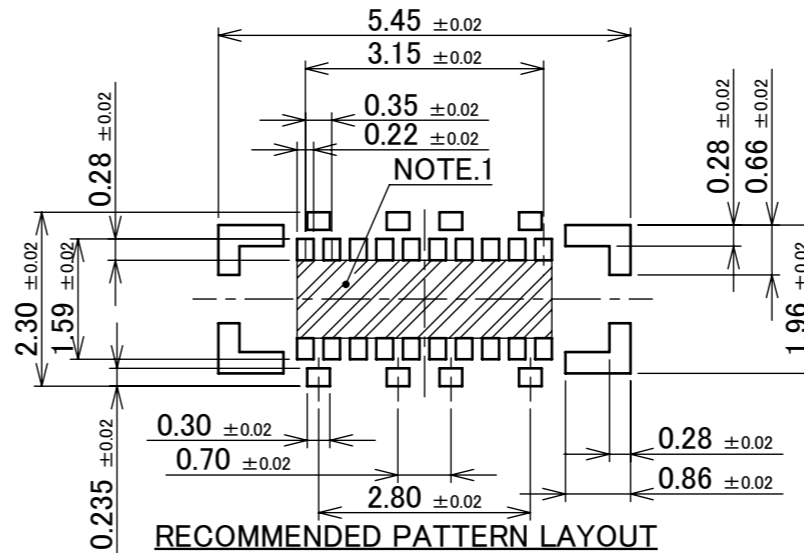
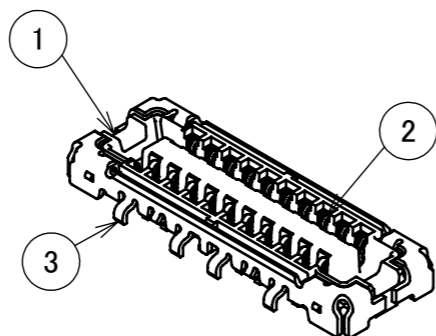

RECOMMENDED PATTERN LAYOUT

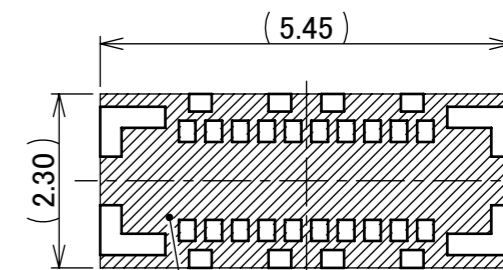

DO NOT MOUNT ANY OTHER COMPONENTS IN THIS AREA.

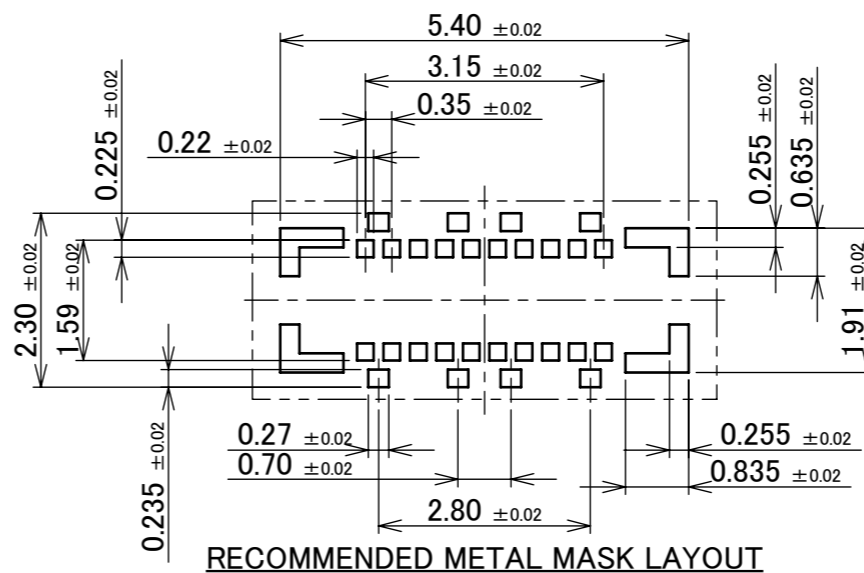

RECOMMENDED METAL MASK LAYOUT

THICKNESS = 0.08 mm

NOTES:
1. FOOT PRINT PATTERN PROHIBITION AREA :
SOLDER RESIST MUST BE APPLIED TO THIS HATCHED AREA
IF SURFACE TRACES ARE ROUNDED.

3	SHELL	COPPER ALLOY	SOLDERING PART Au 0.01 μ m MIN. OVER Ni 1.27 μ m MIN.
2	CONTACT	COPPER ALLOY	CONTACT PART Au 0.05 μ m MIN. OVER Ni 1.27 μ m MIN. SOLDERING PART Au 0.01 μ m MIN. OVER Ni 1.27 μ m MIN.
1	HOUSING	LCP	UL94V-0 BLACK
NO.	DISCRIPTION	MATERIAL	FINISH, REMARKS

ANGLE	±2°	6 OVER 30 MAX.	±0.3	PROJECTION ⊕	SERIES No. R3	CUSTOMER COPY		
		30 OVER 120 MAX.	±0.5					
GENERAL TOLERANCE.				TITLE NOVASTACK® 35-HDN RECEPTACLE ASS'Y	SCALE 10:1	UNIT mm		
DWG.	DATE							
CHK.								
APP.								
				DWG. No.	20865	SIZE A3	SHEET 2/6	REV. 9

PART NO.	Pos.
20865-030E-03	30

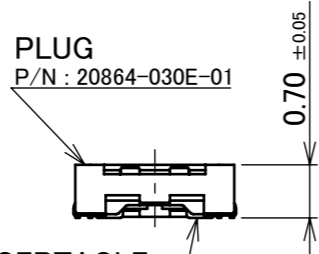

RECEPTACLE
P/N: 20865-030E-03
MATING CONDITION

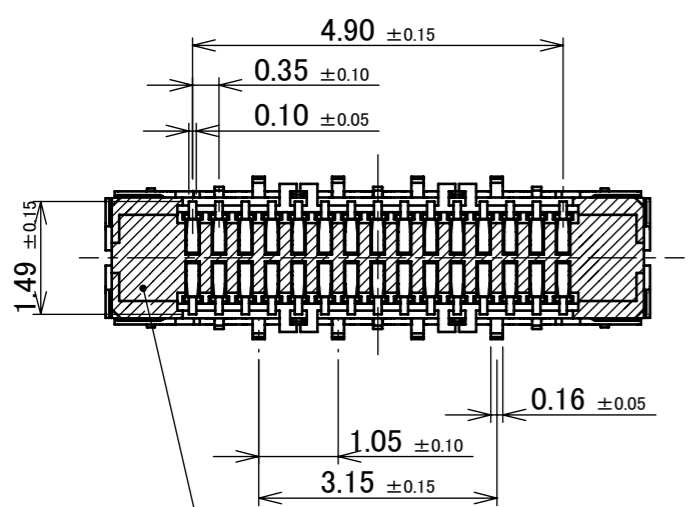
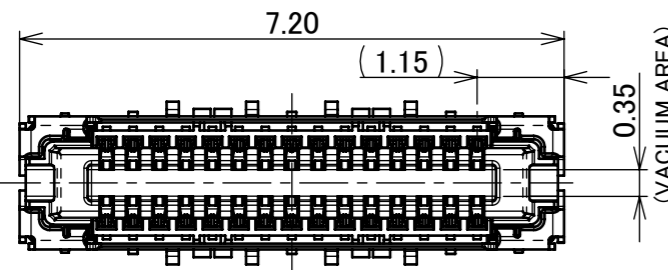

There is a possibility of dent shape in the bottom surface of HOUSING.

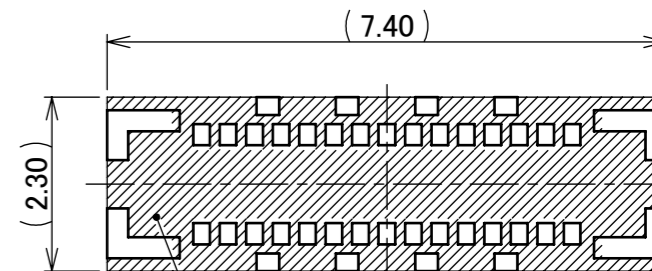
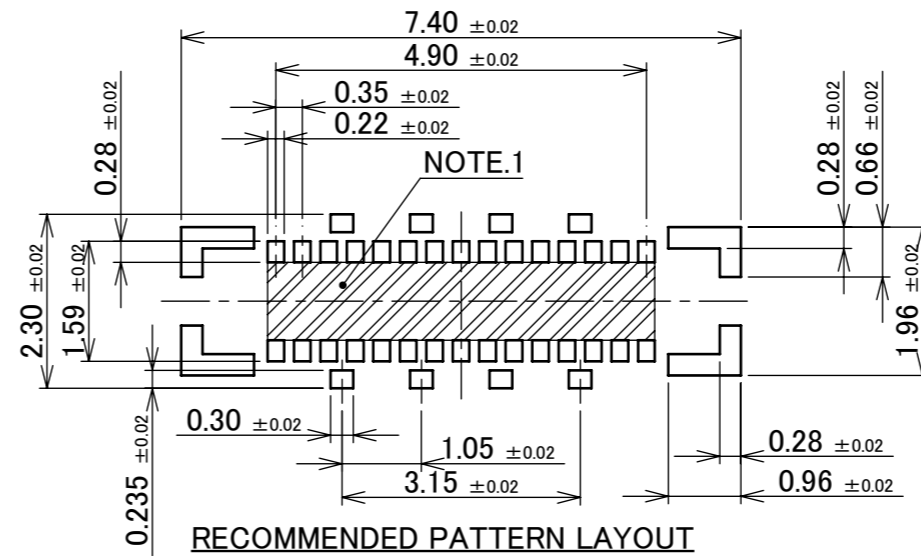
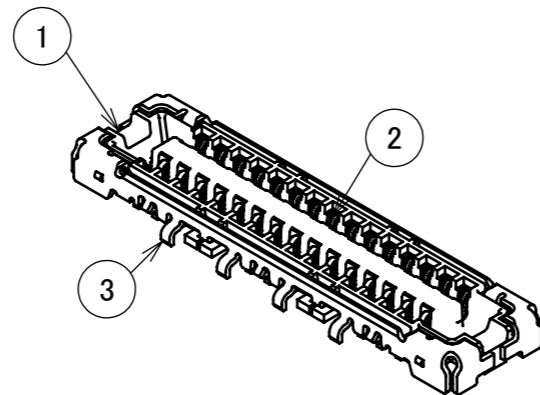

DO NOT MOUNT ANY OTHER COMPONENTS IN THIS AREA.

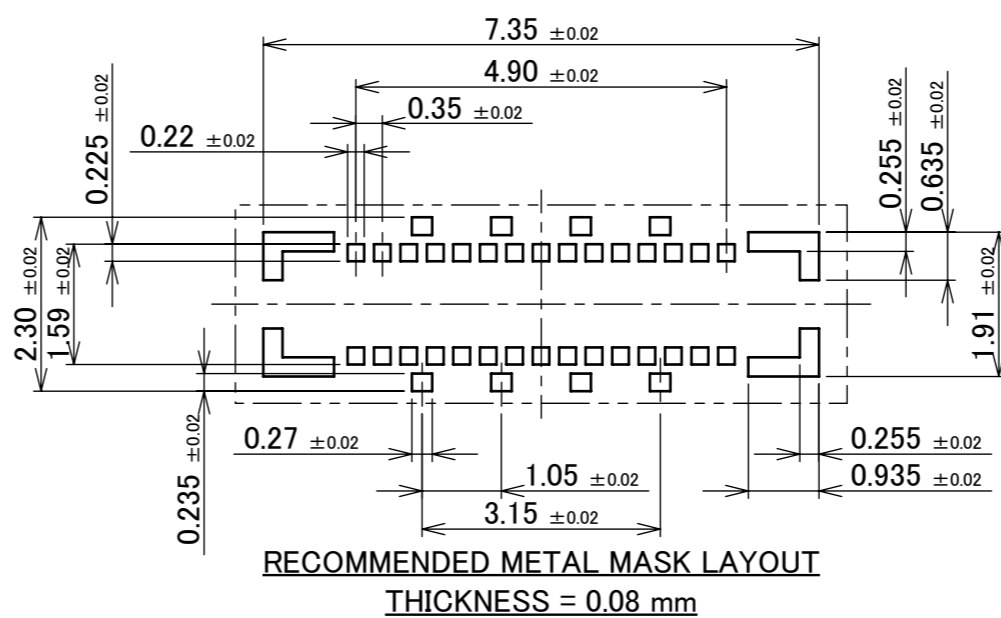

NOTES.
1. FOOT PRINT PATTERN PROHIBITION AREA :
SOLDER RESIST MUST BE APPLIED TO THIS HATCHED AREA
IF SURFACE TRACES ARE ROUNDED.

3	SHELL	COPPER ALLOY	SOLDERING PART Au 0.01 μm MIN. OVER Ni 1.27 μm MIN.
2	CONTACT	COPPER ALLOY	CONTACT PART Au 0.05 μm MIN. OVER Ni 1.27 μm MIN. SOLDERING PART Au 0.01 μm MIN. OVER Ni 1.27 μm MIN.
1	HOUSING	LCP	UL94V-0 BLACK
NO.	DISCRIPTION	MATERIAL	FINISH, REMARKS

ANGLE	±2°	6 OVER 30 MAX.	±0.3	PROJECTION ⊕	SERIES No. R3	CUSTOMER COPY		
		30 OVER 120 MAX.	±0.5					
GENERAL TOLERANCE.				TITLE NOVASTACK® 35-HDN RECEPTACLE ASS'Y	SCALE 10:1	UNIT mm		
DWG.	DATE							
CHK.								
APP.								
				DWG. No.	20865	SIZE A3	SHEET 3/6	REV. 9

ITEMS	SPECIFICATION
APPLICABLE CONNECTOR PART No.	20864-0**E-**
RATING VOLTAGE	60V AC(r.m.s) / DC (PER CONTACT PIN)
RATING AMPERAGE (FOR SIGNAL CONTACT)	10P:1.0 A MAX. AC/DC x PIN COUNTS = 10.0 A (TOTAL) 12P AND OVER : 12.0 A AC/DC (TOTAL)
OPERATING TEMPERATURE	233~358K(-40°C~85°C)
OPERATING HUMIDITY	85% MAX.(NON-CONDENDING)
CONTACT RESISTANCE (FOR SIGNAL CONTACT)	INITIAL : 40mohm MAX. / AFTER TEST : \triangleleft 40mohm MAX.
CONTACT RESISTANCE (FOR GROUND)	INITIAL : 20mohm MAX. / AFTER TEST : \triangleleft 20mohm MAX.
INSULATION RESISTANCE	INITIAL : 1,000Mohm MIN. / AFTER TEST : 500Mohm MIN.
DIELECTRIC WITHSTANDING VOLTAGE	AC250V 1min
DURABILITY	10 CYCLES
MATING FORCE (INITIAL / AFTER TEST)	INITIAL 2.0N/Pin MAX.
UNMATING FORCE (INITIAL / AFTER TEST)	10 CYCLES 0.15N/Pin MIN.
COPLANARITY	0.08 MAX.
PRODUCT SPECIFICATION	PRS-2607
TEST REPORT	TR-19055
PACKING STANDARD	PST-18023
INSTRUCTION MANUAL	HIM-18019
APPEARANCE CRITERIA No.	QLS-A***

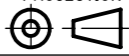
ANGLE	$\pm 2^\circ$	6 OVER 30 MAX.	± 0.3	PROJECTION 	SERIES No. R3	CUSTOMER COPY	
6 MAX.	± 0.2	30 OVER 120 MAX.	± 0.5				
GENERAL TOLERANCE.				TITLE NOVASTACK® 35-HDN RECEPTACLE ASS'Y	SCALE	I-PEX	
DWG.	DATE						
CHK.							
APP.							
DWG. No.	20865			UNIT mm	SIZE A3	SHEET 4/6	REV. 9

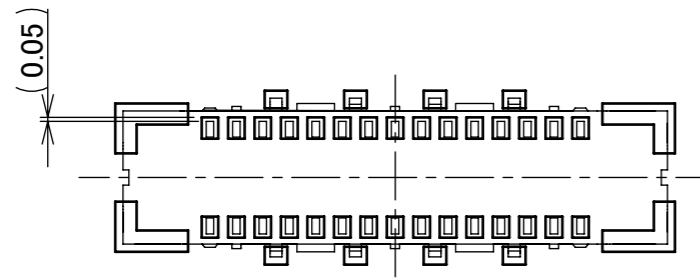

CONNECTOR ON RECOMMENDED FOOTPRINT PATTERN

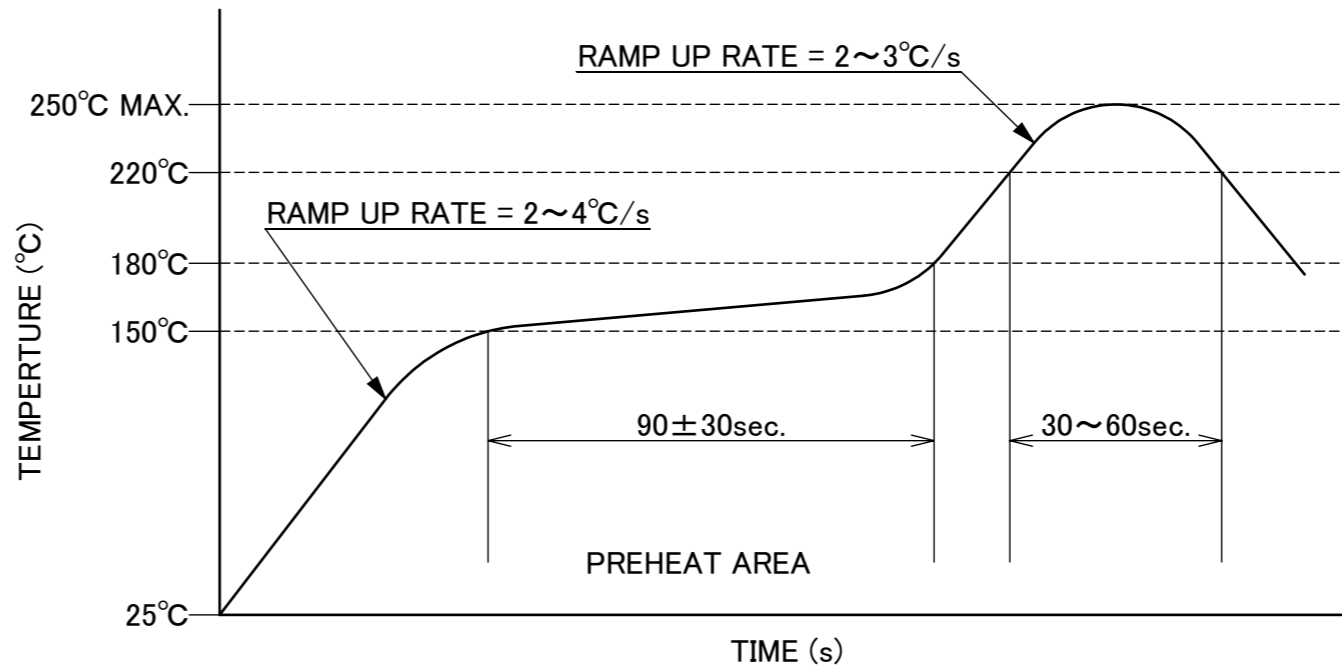

REFLOW TEMPERATURE PROFILE
 SENJU METAL INDUSTRY CO., LTD. : M705-SHF(Sn96.5 Ag3.0 Cu0.5)

ANGLE	±2°	6 OVER 30 MAX.	±0.3	PROJECTION 	SERIES No. R3	CUSTOMER COPY		
6 MAX.	±0.2	30 OVER 120 MAX.	±0.5					
GENERAL TOLERANCE.				TITLE NOVASTACK® 35-HDN RECEPTACLE ASS'Y	SCALE 10:1	UNIT I-PEX		
DWG.	DATE							
CHK.								
APP.								
				DWG. No.	20865	SIZE A3	SHEET 5/6	REV. 9

PART NO.	Pos.	A	B	C	QTY. PER EMBOSS REEL (PIECES / REEL)	QTY. PER PACKING CARTON (REELS / CARTON)
20865-010E-03	10	12.0	5.50	3.80	20,000 / REEL	20,000 × 9 REELS=180,000
20865-020E-03	20	16.0	7.50	5.55		20,000 × 7 REELS=140,000
20865-030E-03	30	16.0	7.50	7.50		

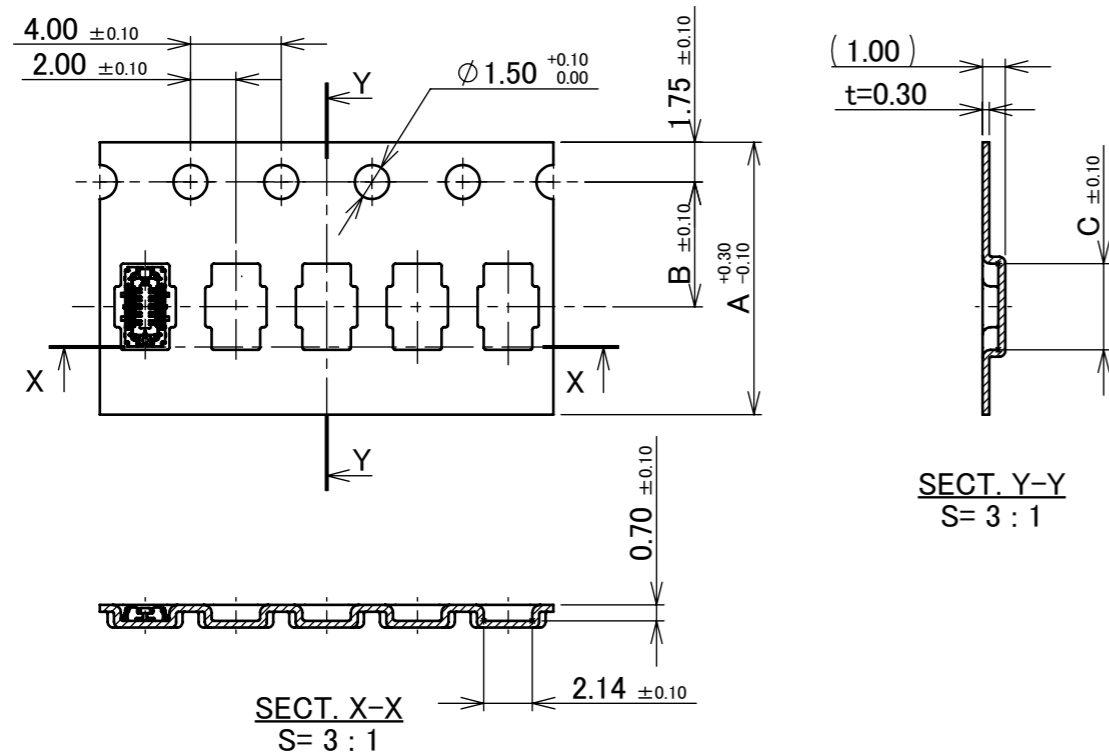
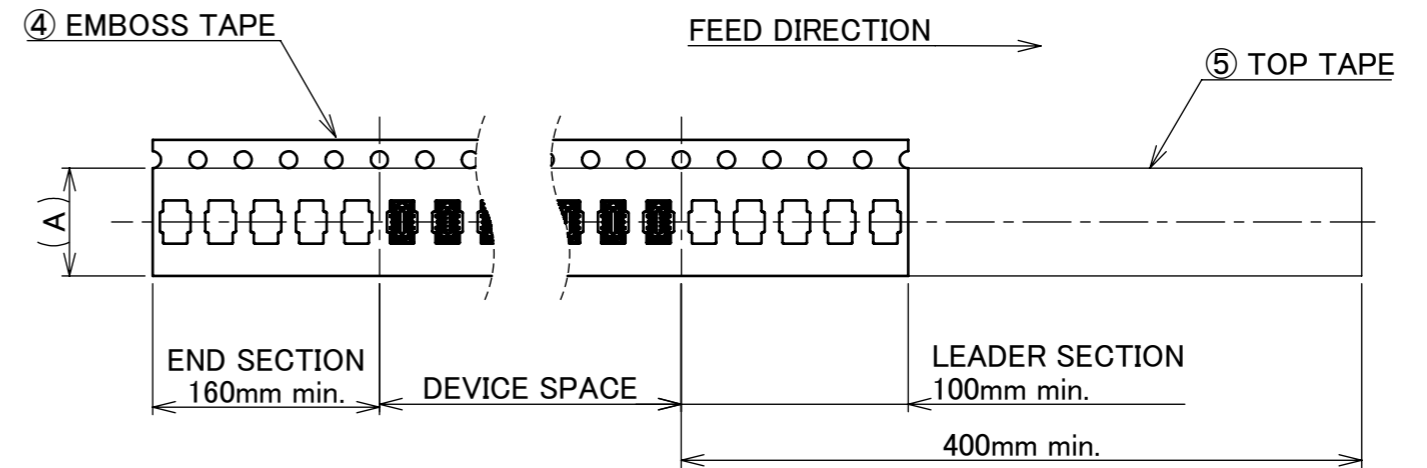
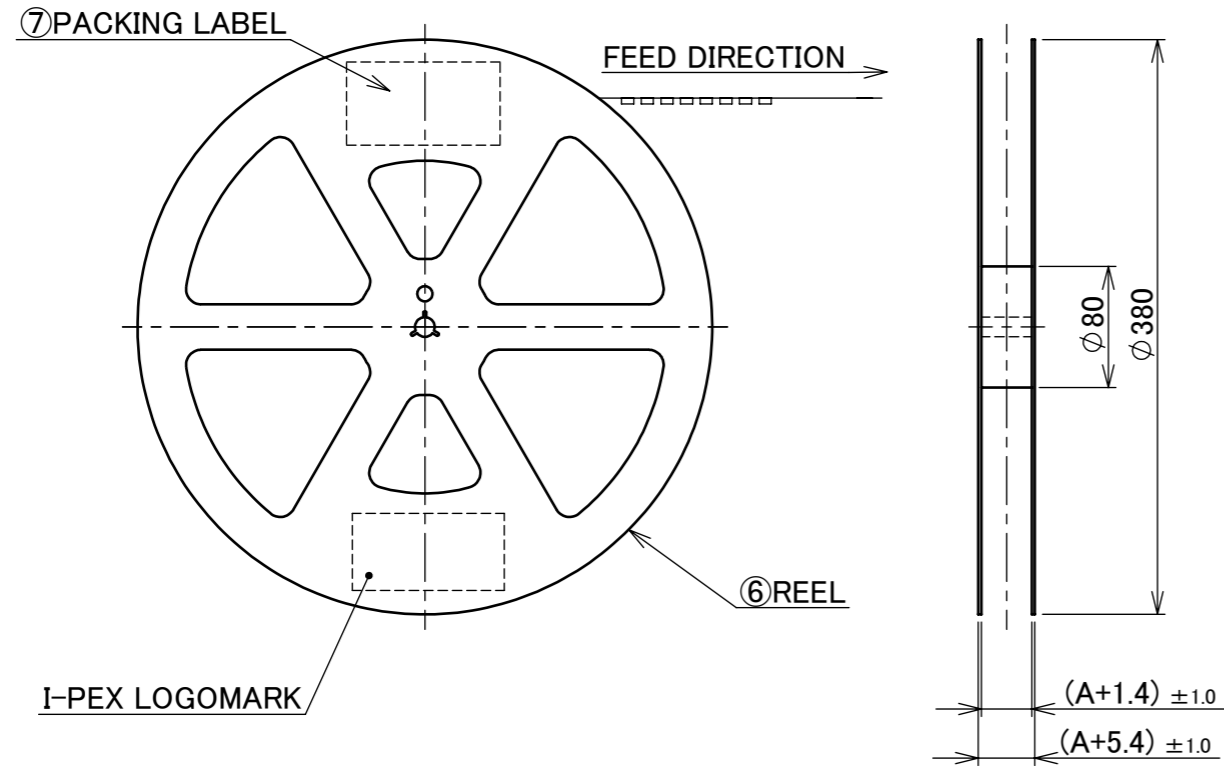

- NOTES.
- TAPING SPECIFICATION FOLLOWS JIS C 0806 (IEC 60286-3).
 - MAKE EMPTY SECTION OF LEADER AND END ON EACH END OF THE TAPE.
 - TOP TAPE SHALL NOT STICK OUT FROM EMBOSS TAPE.
 - TOP TAPE SHALL NOT COVER FEED HOLE.

NO.	DISCRIPTION	MATERIAL	FINISH , REMARKS
7	PACKING LABEL	-	-
6	REEL	PS	ANTI-STATIC TYPE BLACK
5	TOP TAPE	PET t=0.062 TRANSPARENCY	ANTI-STATIC TYPE
4	EMBOSS TAPE	PS t=0.3 TRANSPARENCY	ANTI-STATIC TYPE

ANGLE	$\pm 2^\circ$	6 OVER 30 MAX.	± 0.3	PROJECTION 	SERIES No. R3	CUSTOMER COPY
6 MAX.	± 0.2	30 OVER 120 MAX.	± 0.5			
GENERAL TOLERANCE.				TITLE NOVASTACK® 35-HDN RECEPTACLE ASS'Y	SCALE 1:X	UNIT mm
DWG.	DATE		DWG. No. 20865			
CHK.						
APP.						
SIZE	A3	SHEET	6/6	REV.	9	