

Recommended P/N 20713-004E-01

PART No.	Q'ty/REEL
20713-004E-01	20K
20713-004E-02	5K



Halogen Free



RoHS Compliant

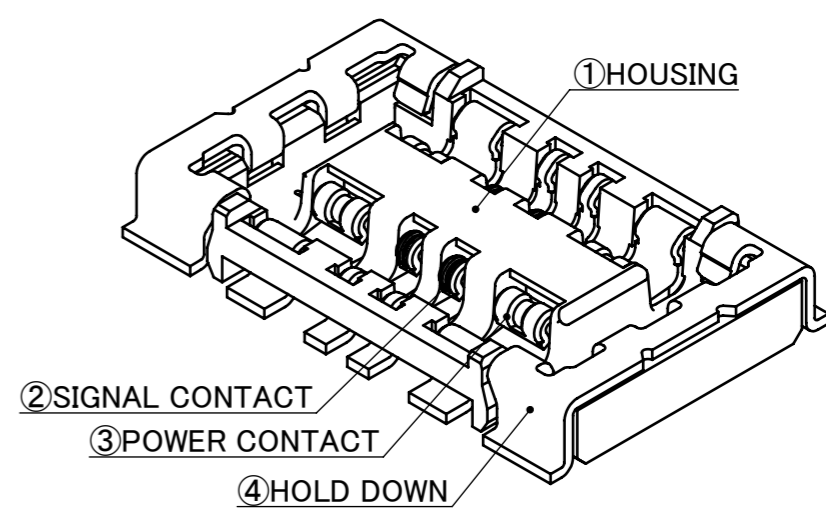
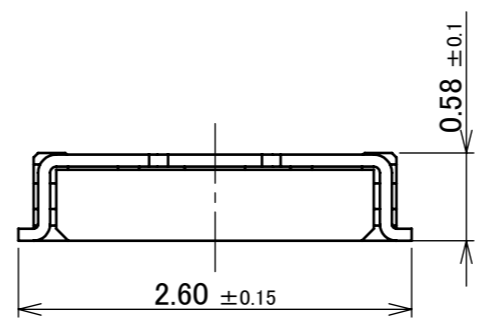
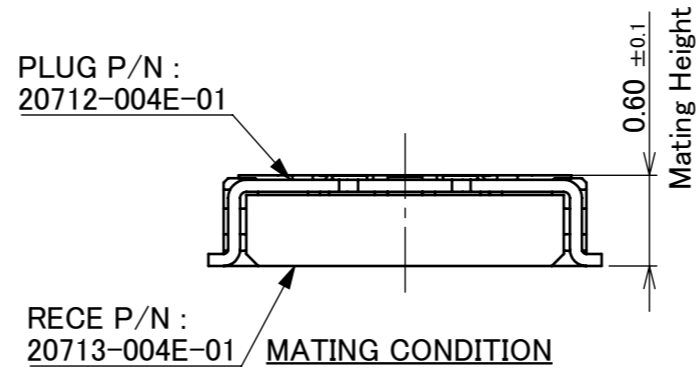
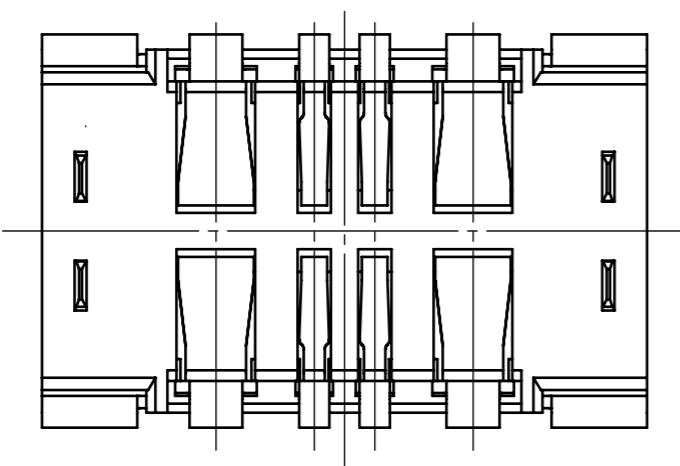
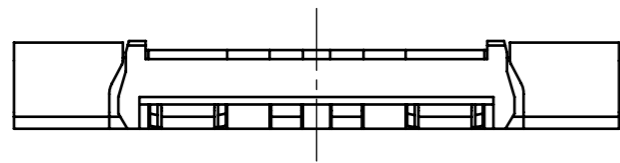
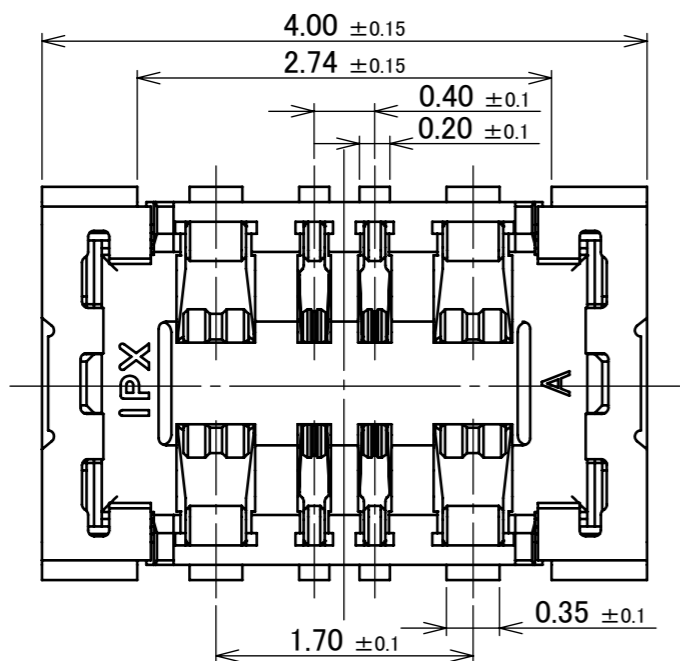

NO.	DISCRIPTION	MATERIAL	FINISH , REMARKS
4	HOLD DOWN	PHOSPHOR BRONZE	ALL OVER Ni 1.27 μ m MIN. SOLDERING PART Au 0.01 μ m MIN.
3	POWER CONTACT	CORSON ALLOY	ALL OVER Ni 1.27 μ m MIN. CONTACT PART Au 0.05 μ m MIN./ SOLDERING PART Au 0.02 μ m MIN.
2	SIGNAL CONTACT	CORSON ALLOY	ALL OVER Ni 1.27 μ m MIN. CONTACT PART Au 0.05 μ m MIN./ SOLDERING PART Au 0.02 μ m MIN.
1	HOUSING	LCP	UL94V-0, BLACK

REV.	ECN	BY	DATE	APP.	APP.	ANGLE	PROJECTION	SERIES No.	TITLE	SCALE	CUSTOMER COPY	
						±2° 6 OVER 30 MAX. ±0.3 6 MAX. ±0.2 30 OVER 120 MAX. ±0.5	①	R3	NOVASTACK® -B RECEPTACLE ASS'Y	20:1	I-PEX	
						GENERAL TOLERANCE.				mm		
3	Z220205	K.W	2022/02/28	Y.H							1/5	
2	Z180691	R.H	2018/05/30	TAK	DWG.							
1	Z161155	H.I	2016/09/15	Y.S	H.Ikari	DATE						
0	Z160990	H.I	2016/08/09		CHK.	2016/08/09						
REV.	ECN	BY	DATE	APP.	APP.		DWG. No.	20713			REV.	3

ITEMS	SPECIFICATION
APPLICABLE CONNECTOR PART No.	20712-004E-0*
RATING VOLTAGE	50V AC (PER CONTACT PIN)
RATING AMPERAGE (FOR SIGNAL CONTACT)	1.0A AC/DC (PER CONTACT PIN)/ 4.0A AC/DC(TOTAL)
RATING AMPERAGE (FOR POWER CONTACT)	6.0A AC/DC (PER CONTACT PIN)/ 24.0A AC/DC(TOTAL)
OPERATING TEMPERATURE	233~358K(-40°C~+85°C)
OPERATING HUMIDITY	85% MAX.(NON-CONDENSING)
CONTACT RESISTANCE (FOR SIGNAL CONTACT)	INITIAL : 40mohm MAX. / AFTER TEST : \triangleleft 20mohm MAX.
CONTACT RESISTANCE (FOR POWER CONTACT)	INITIAL : 20mohm MAX. / AFTER TEST : \triangleleft 20mohm MAX.
INSULATION RESISTANCE	INITIAL : 1,000Mohm MIN. / AFTER TEST : 100Mohm MIN.
DIELECTRIC WITHSTANDING VOLTAGE	AC250V 1min
DURABILITY	30 CYCLES
MATING FORCE (INITIAL / AFTER TEST)	40N MAX.
UNMATING FORCE (INITIAL / AFTER TEST)	INITIAL: 10N MIN. AFTER TEST: 7N MIN.
COPLANARITY	0.08 MAX.
PRODUCT SPECIFICATION	PRS-2284
TEST REPORT	TR-16098
PACKING STANDARD	PST-15123 (20K/REEL) PST-16057 (5K/REEL)
INSTRUCTION MANUAL	HIM-16033
APPEARANCE CRITERIA No.	QLS-A***

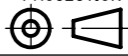
ANGLE	$\pm 2^\circ$	6 OVER 30 MAX.	± 0.3	PROJECTION 	SERIES No. R3	CUSTOMER COPY		
6 MAX.	± 0.2	30 OVER 120 MAX.	± 0.5					
GENERAL TOLERANCE.				TITLE NOVASTACK® -B RECEPTACLE ASS'Y	SCALE	I-PEX		
DWG.	DATE							
CHK.								
APP.								
DWG. No.	20713			UNIT mm	SIZE A3	SHEET 2/5	REV. 3	

MASK THICKNESS	A
t=0.08	2.90
t=0.1	2.74
t=0.12	2.64

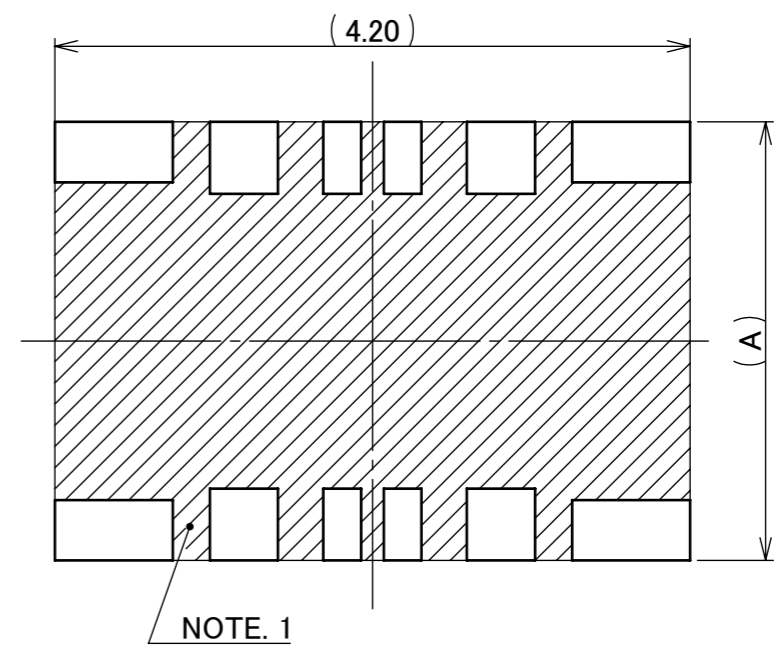
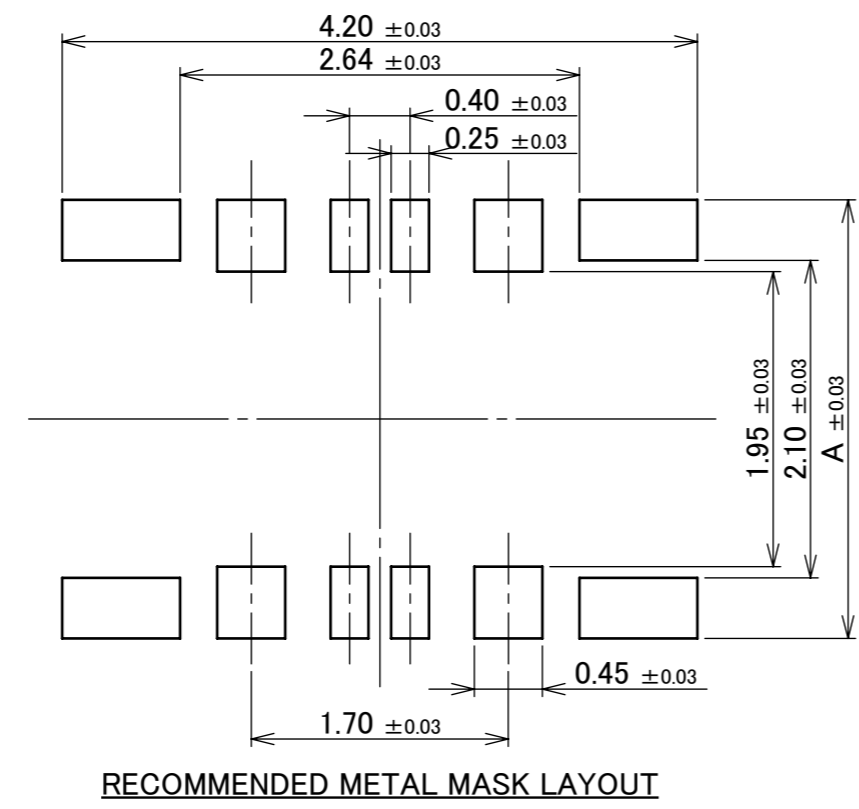
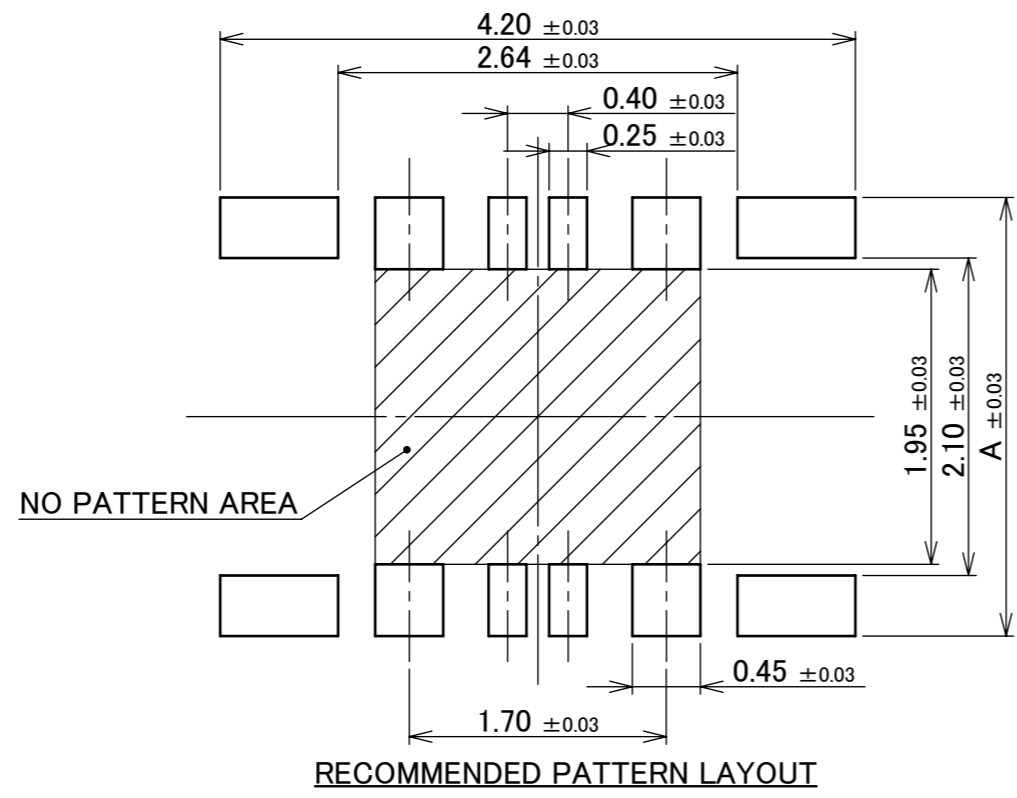

NOTES.
1. THIS AREA CANNOT MOUNT ANOTHER COMPONENTS.

ANGLE	±2°	6 OVER 30 MAX.	±0.3	PROJECTION	SERIES No.	CUSTOMER COPY	
	6 MAX.	±0.2	30 OVER 120 MAX.	±0.5	R3	I-PEX	
GENERAL TOLERANCE.				TITLE		SCALE	I-PEX
DWG.	DATE			NOVASTACK® -B RECEPTACLE ASS'Y		20:1	
CHK.						UNIT	
APP.				DWG. No.		mm	
				20713		SIZE	SHEET
						A3	3/5
						REV.	3

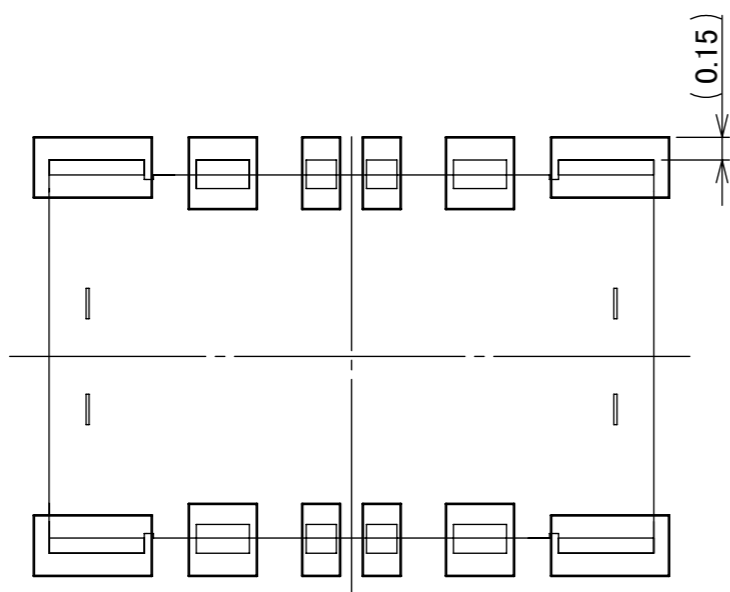

CONNECTOR ON RECOMMENDED FOOTPRINT PATTERN

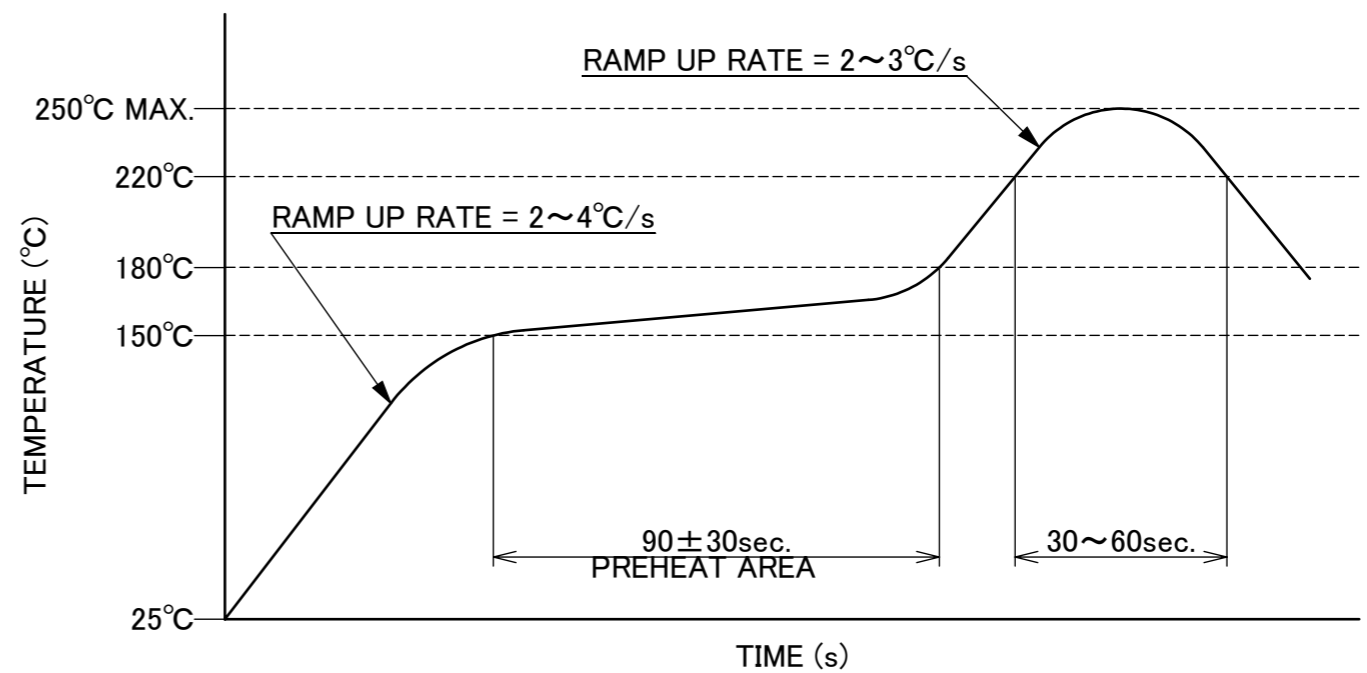

REFLOW TEMPERATURE PROFILE
 SENJU METAL INDUSTRY CO., LTD. : M705-SHF(Sn96.5 Ag3.0 Cu0.5)

ANGLE	±2°	6 OVER 30 MAX.	±0.3	PROJECTION 	SERIES No. R3	CUSTOMER COPY		
6 MAX.	±0.2	30 OVER 120 MAX.	±0.5					
GENERAL TOLERANCE.				TITLE NOVASTACK® -B RECEPTACLE ASS'Y	SCALE 20:1	UNIT I-PEX		
DWG.	DATE							
CHK.								
APP.								
				DWG. No.	20713	SIZE A3	SHEET 4/5	REV. 3

PART NO.	B	C	QTY. PER EMBOSS REEL (PIECES / REEL)	QTY. PER PACKING CARTON (REELS / CARTON)
20713-004E-01	80	380	20,000 / REEL	20,000 × 8 REELS = 160,000
20713-004E-02	100	254	5,000 / REEL	5,000 × 8 REELS = 40,000

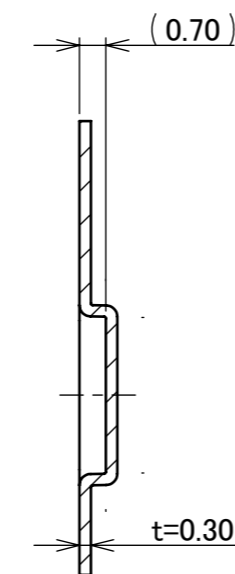
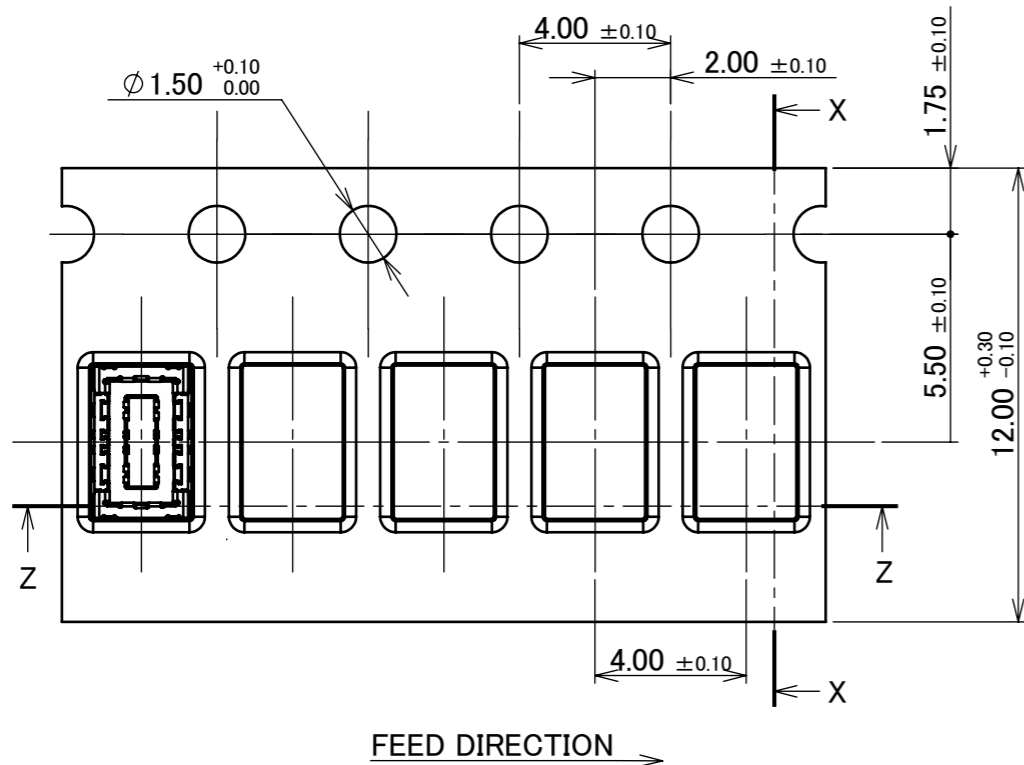
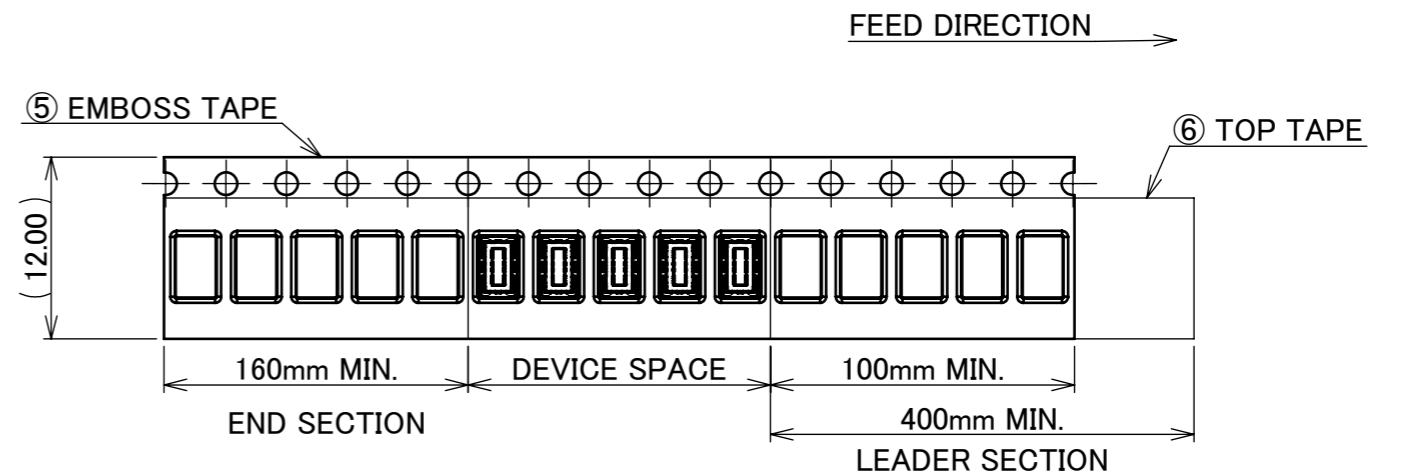
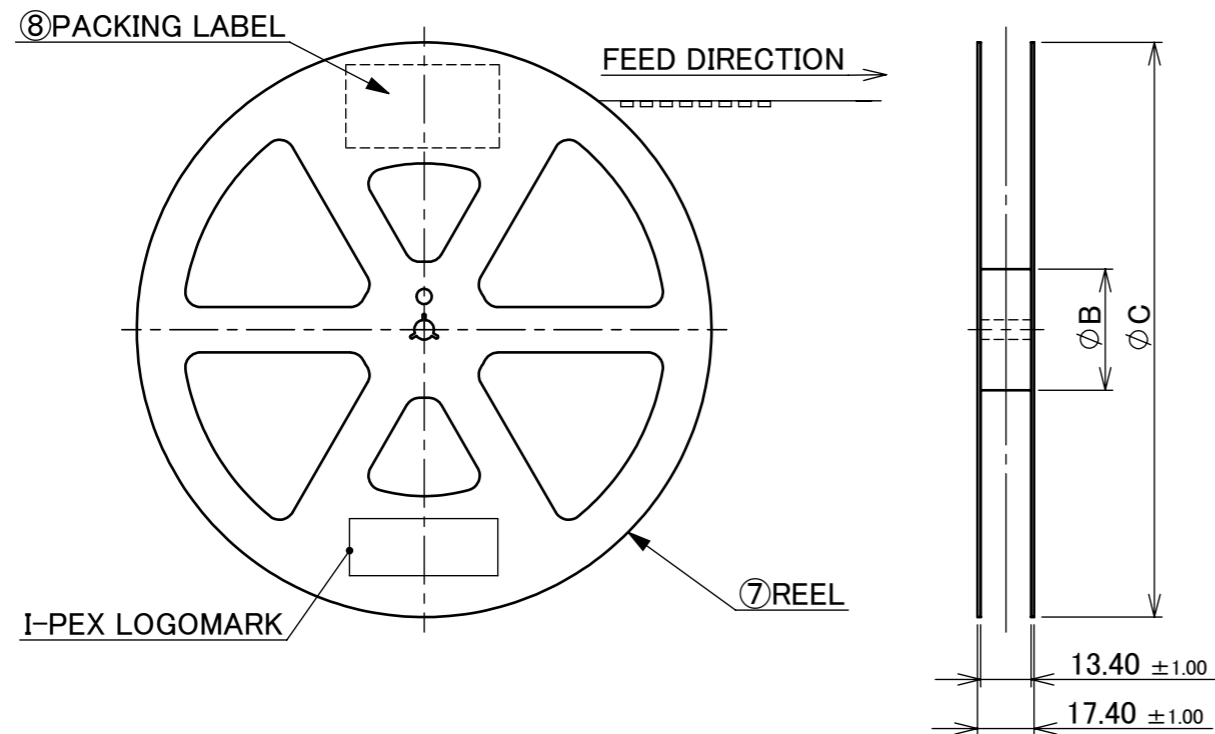

SECT. X-X
(S=5:1)

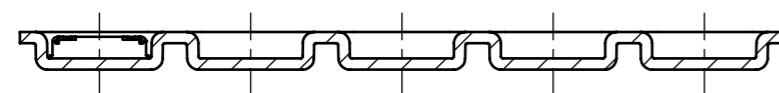

SECT. Z-Z
(S=5:1)

NOTES.

- TAPING SPECIFICATION FOLLOWS JIS C 0806 (IEC 60286-3).
- MAKE EMPTY SECTION OF LEADER AND END ON EACH END OF THE TAPE.
- TOP TAPE SHALL NOT STICK OUT FROM EMBOSS TAPE.
- TOP TAPE SHALL NOT COVER FEED HOLE.

NO.	DESCRIPTION	MATERIAL	FINISH, REMARKS
8	PACKING LABEL	-	-
7	REEL	PS	ANTI-STATIC TYPE BLACK
6	TOP TAPE	PET t=0.062 TRANSPARENCY	ANTI-STATIC TYPE
5	EMBOSS TAPE	PS TRANSPARENCY	ANTI-STATIC TYPE

ANGLE	±2°	6 OVER 30 MAX.	±0.3	PROJECTION	SERIES No.	CUSTOMER COPY			
6 MAX.	±0.2	30 OVER 120 MAX.	±0.5		R3				
GENERAL TOLERANCE.				TITLE	NOVASTACK® -B		SCALE		
DWG.	DATE			RECEPTACLE ASS'Y		UNIT	1:X		
CHK.						mm	I-PEX		
APP.				DWG. No.	20713	SIZE	SHEET	REV.	
						A3	5/5	3	