

PART NO.

3224-0001

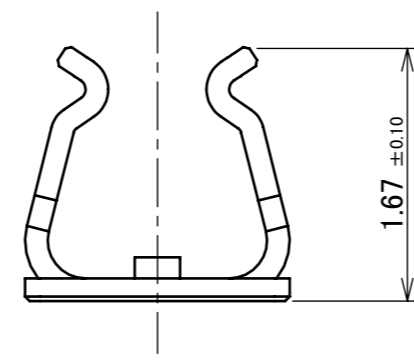
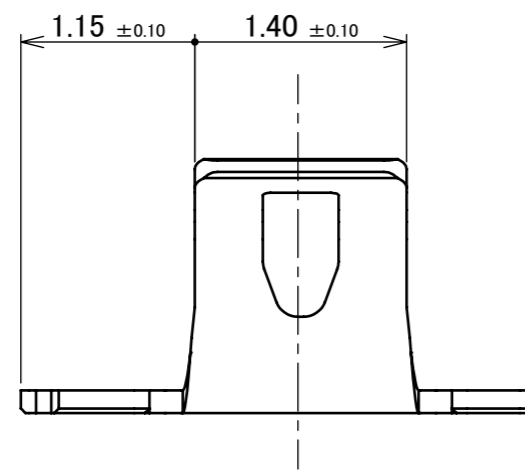
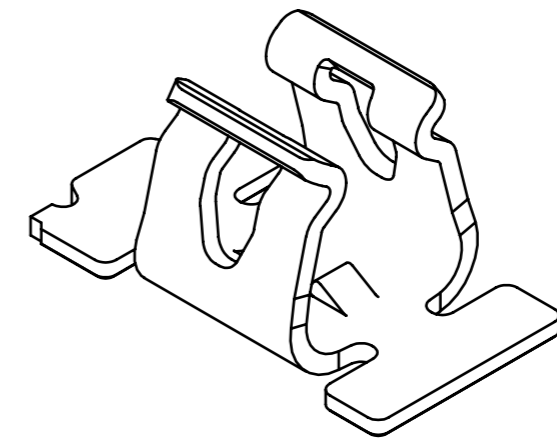
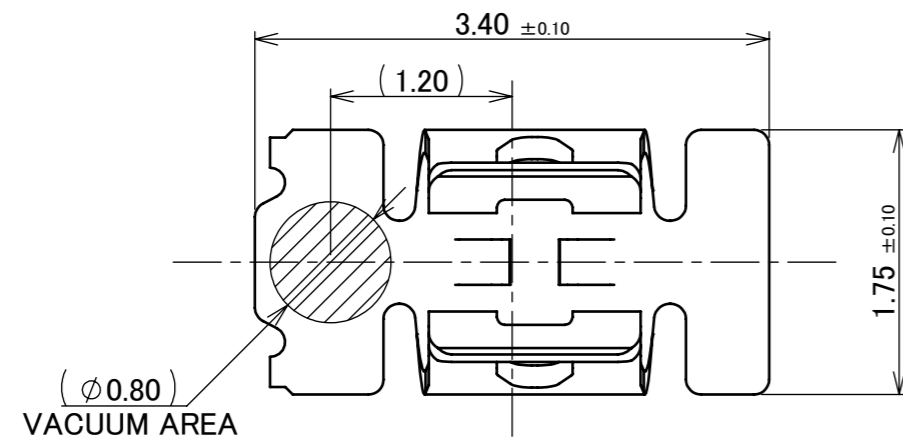
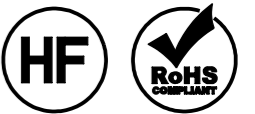

1	MP-A04	PHOSPHOR BRONZE	CONTACT PART Sn 2.00 μm MIN. OVER Ni 1.00 μm MIN. SOLDERING PART Sn 1.00 μm MIN.OVER Ni 0.50 μm MIN.
NO.	DESCRIPTION	MATERIAL	FINISH , REMARKS

6	Z221060	H.T	2022/09/29	Y.H	ANGLE	±2°	6 OVER 30 MAX.	±0.3	PROJECTION ⊕	SERIES No. R0	CUSTOMER COPY			
5	Z211214	H.T	2021/10/05	M.T	6 MAX.	±0.2	30 OVER 120 MAX.	±0.5						
4	Z211165	H.T	2021/09/24	M.T	GENERAL TOLERANCE.			TITLE	MP-A04	SCALE 20:1	UNIT mm			
3	Z180872	S.K	2018/09/20	Ken	DWG.	DATE		S.Taguchi				2015/11/20	SIZE A3	SHEET 1/7
2	Z180302	M.N	2018/03/08	Ken	CHK.	K.Yotsutani								
1	Z170683	M.N	2017/06/13	Ken	APP.	T.Takano		DWG. No.	3224	REV.	6			
REVISION RECORD														

PART NO.
3224-0003

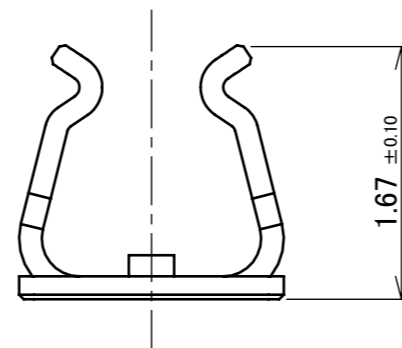
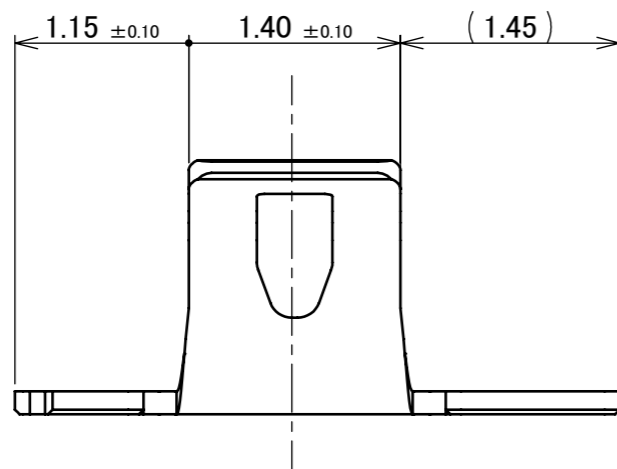
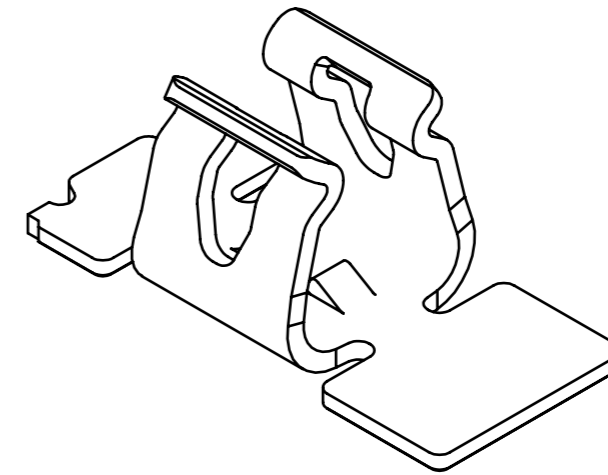
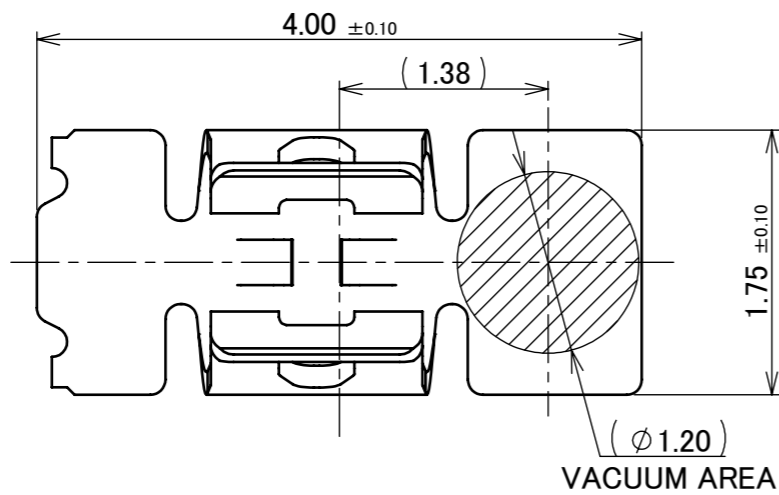
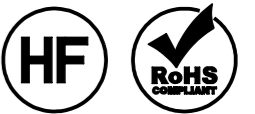

ANGLE	±2°	6 OVER 30 MAX.	±0.3	PROJECTION ⊕	SERIES No. R0	CUSTOMER COPY				
6 MAX.	±0.2	30 OVER 120 MAX.	±0.5							
GENERAL TOLERANCE.				TITLE		SCALE	I-PEX			
DWG.	DATE			MP-A04		20:1				
CHK.						UNIT				mm
APP.						DWG. No.				3224
						A3	2/7	6		

ITEMS	SPECIFICATION
APPLICABLE CONNECTOR PART No.	<ul style="list-style-type: none"> •CABLE CLAMP (3mm) FOR Φ 1.37 COAXIAL CABLE (P/N: 3223-030*) •CABLE CLAMP (6mm) FOR Φ 1.37 COAXIAL CABLE (P/N: 3223-060*) •CABLE JACKET (OUTSIDE DIAMETER Φ 1.37\pm0.08) OF Φ 1.37 COAXIAL CABLE
OPERATING TEMPERATURE	233~358K(-40°C~+85°C)
OPERATING HUMIDITY	85% MAX.(NON-CONDENSING)
CONTACT RESISTANCE	INITIAL : 70mohm MAX. / AFTER TEST : 70mohm MAX.
DURABILITY	5 CYCLES
MATING FORCE (INITIAL / AFTER TEST)	INITIAL : 25N MAX. / AFTER TEST : 25N MAX.
UNMATING FORCE (INITIAL / AFTER TEST)	INITIAL : 3N MIN. / AFTER TEST : 2N MIN.
PRODUCT SPECIFICATION	PRS-2235
TEST REPORT	TR-16134
PACKING STANDARD	PST-15066
INSTRUCTION MANUAL	HIM-16012
APPEARANCE CRITERIA No.	QLS-A***

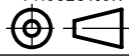
ANGLE	$\pm 2^\circ$	6 OVER 30 MAX.	± 0.3	PROJECTION 	SERIES No. R0	CUSTOMER COPY		
6 MAX.	± 0.2	30 OVER 120 MAX.	± 0.5					
GENERAL TOLERANCE.				TITLE MP-A04	SCALE -	I-PEX		
DWG.	DATE							
CHK.								
APP.								
				DWG. No.	3224	SIZE A3	SHEET 3/7	REV. 6

① ϕ 1.37 COAXIAL CABLE WITH 3mm CABLE CLAMP (P/N : 3223-0302)

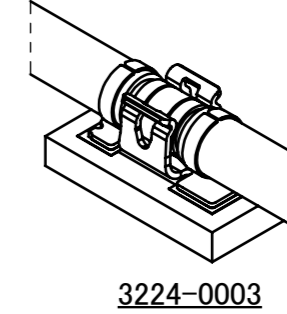
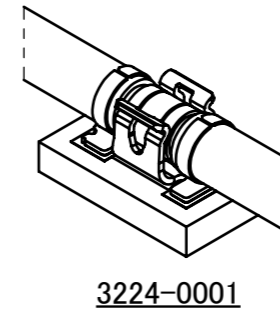
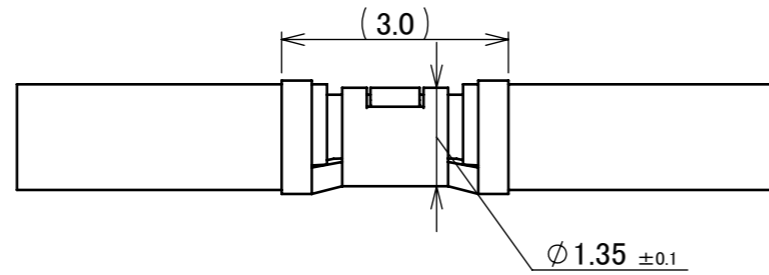

② ϕ 1.37 COAXIAL CABLE WITH 6mm CABLE CLAMP (P/N : 3223-0602)

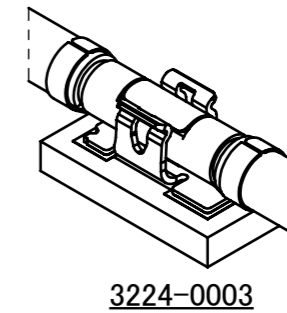
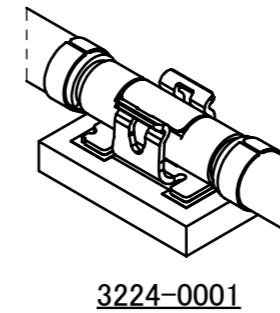
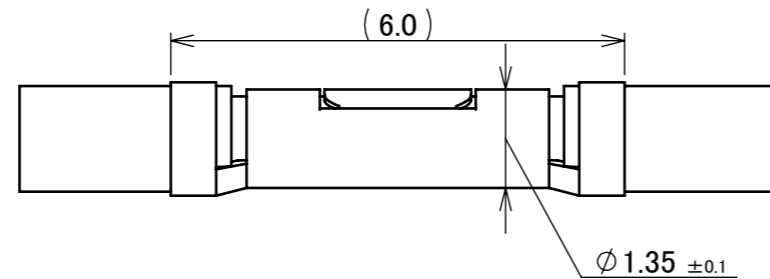

③ ϕ 1.37 COAXIAL CABLE

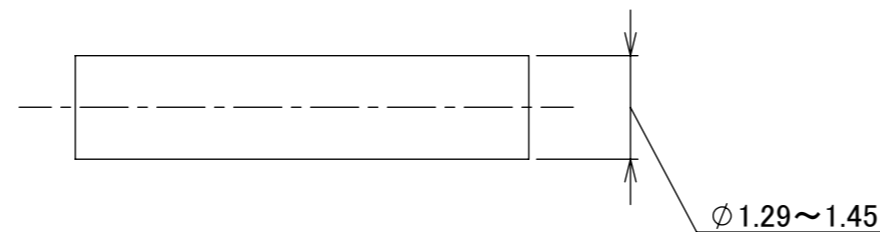

APPLICABLE CABLE

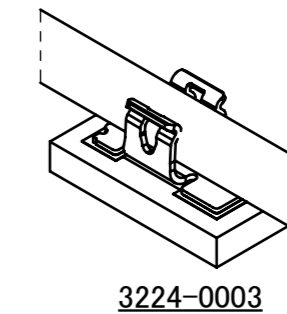
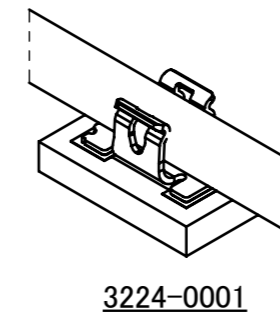

MATING CONDITION
(S = 6/1)

NOTE.
1. ONLY A SIMILAR CABLE IS REPLACEABLE.

ANGLE	$\pm 2^\circ$	6 OVER 30 MAX.	± 0.3	PROJECTION 	SERIES No. R0	CUSTOMER COPY		
	6 MAX.	± 0.2	30 OVER 120 MAX.					± 0.5
GENERAL TOLERANCE.				TITLE		SCALE	I-PEX	
DWG.	DATE			MP-A04		10:1		
CHK.						UNIT		
APP.				DWG. No.		SIZE	SHEET	REV.
				3224		A3	4/7	6

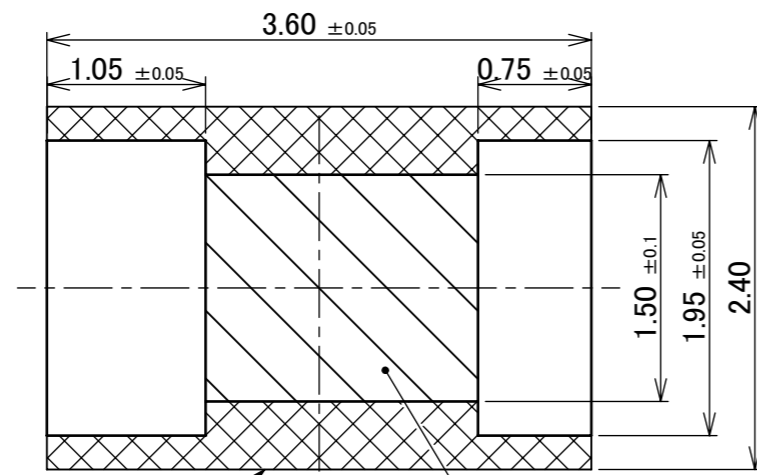

SEE NOTE. 3
 SEE NOTE. 2
RECOMMENDED FOOTPRINT PATTERN
 3224-0001

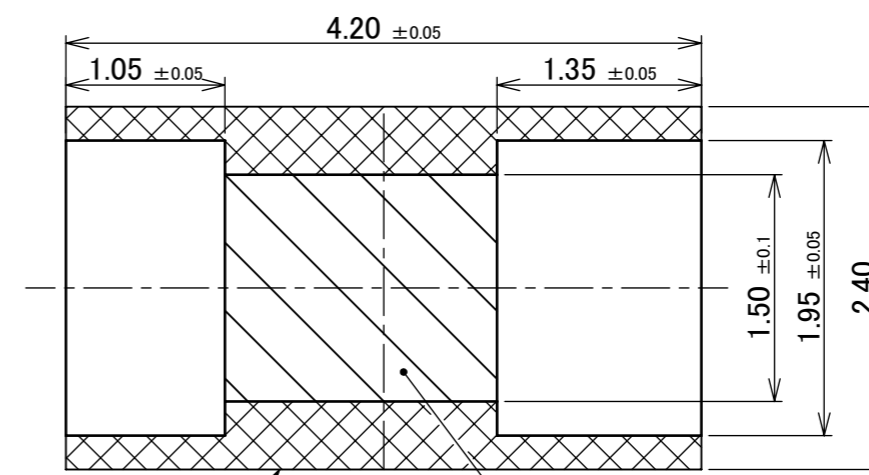

SEE NOTE. 3
 SEE NOTE. 2
RECOMMENDED FOOTPRINT PATTERN
 3224-0003

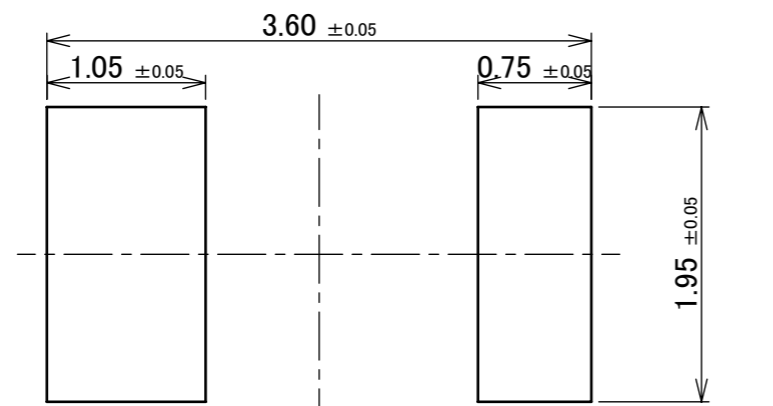

METAL MASK
 3224-0001
 THICKNESS: 0.10mm

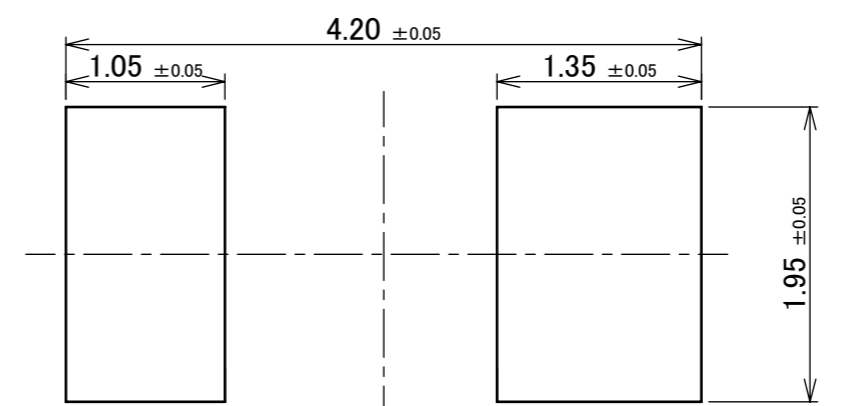

METAL MASK
 3224-0003
 THICKNESS: 0.10mm

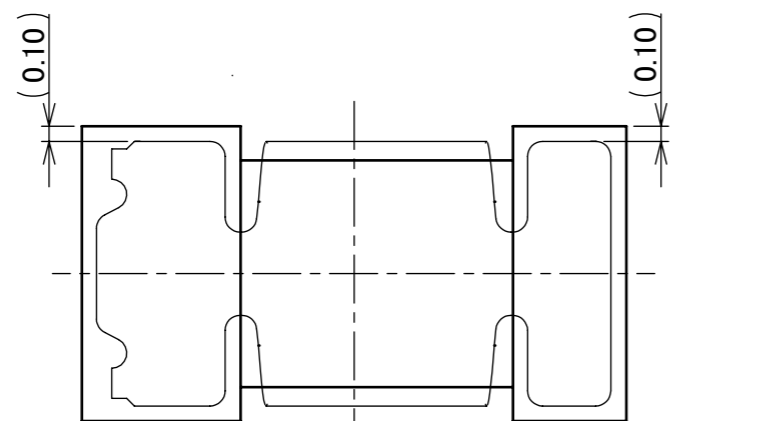

CONNECTOR ON RECOMMENDED FOOTPRINT PATTERN
 3224-0001

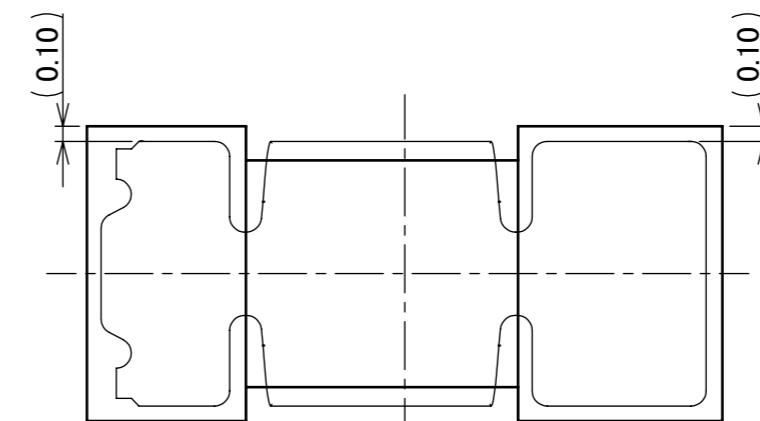

CONNECTOR ON RECOMMENDED FOOTPRINT PATTERN
 3224-0003

- NOTES.
 2. PATTERN AND RESIST PROHIBITION AREA.
 3. THIS AREA CANNOT MOUNT ANOTHER COMPONENTS.

ANGLE	±2°	6 OVER 30 MAX.	±0.3	PROJECTION 	SERIES No. R0	CUSTOMER COPY	
	6 MAX.	±0.2	30 OVER 120 MAX.				
GENERAL TOLERANCE.				TITLE	SCALE 20:1	I-PEX	
DWG.	DATE			MP-A04			
CHK.				DWG. No.	SIZE A3	SHEET 5/7	REV. 6
APP.				3224			

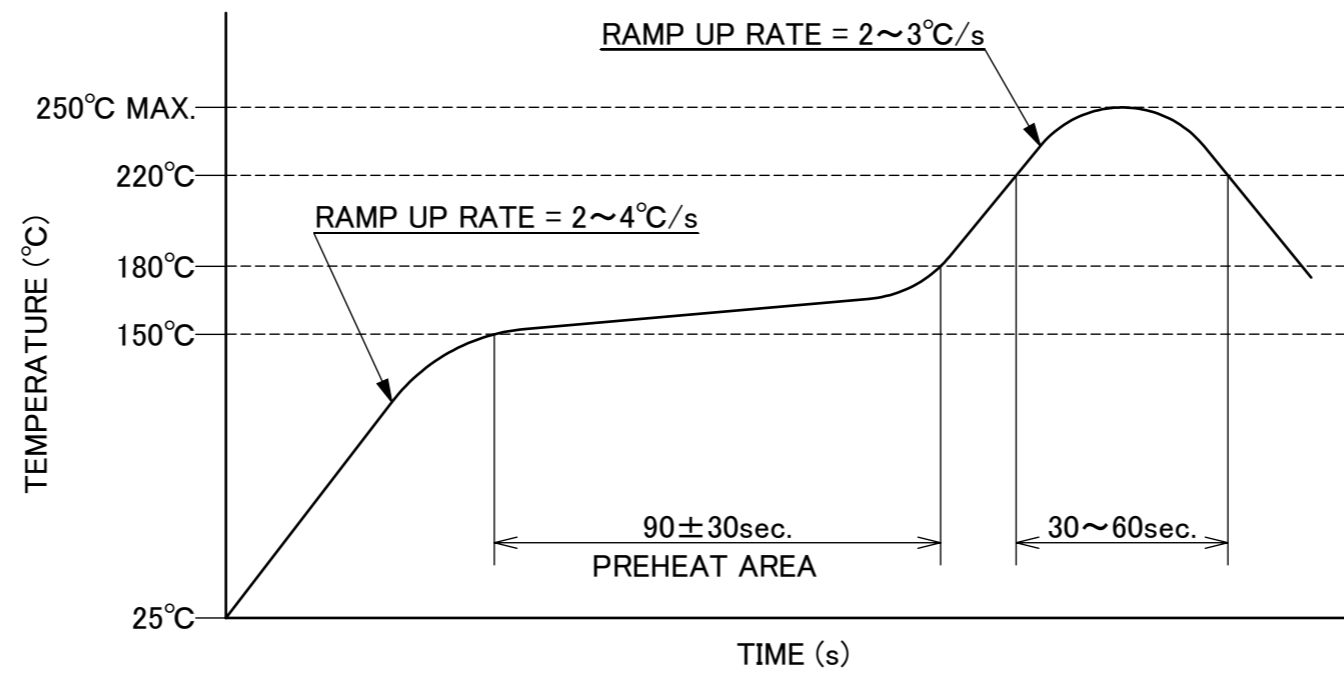

REFLOW TEMPERATURE PROFILE
 SENJU METAL INDUSTRY CO., LTD. : M705-SHF(Sn96.5 Ag3.0 Cu0.5)

ANGLE	±2°	6 OVER 30 MAX.	±0.3	PROJECTION 	SERIES No. R0	CUSTOMER COPY		
6 MAX.	±0.2	30 OVER 120 MAX.	±0.5					
GENERAL TOLERANCE.				TITLE MP-A04	SCALE -	I-PEX		
DWG.	DATE							
CHK.								
APP.								
				DWG. No.	3224	SIZE A3	SHEET 6/7	REV. 6

PART NO.	A	QTY. PER EMBOSS REEL (PIECES / REEL)	QTY. PER PACKING CARTON (REELS / CARTON)
3224-0001	3.53	10,000 / REEL	10 REELS / CARTON = 100,000
3224-0003	4.13		

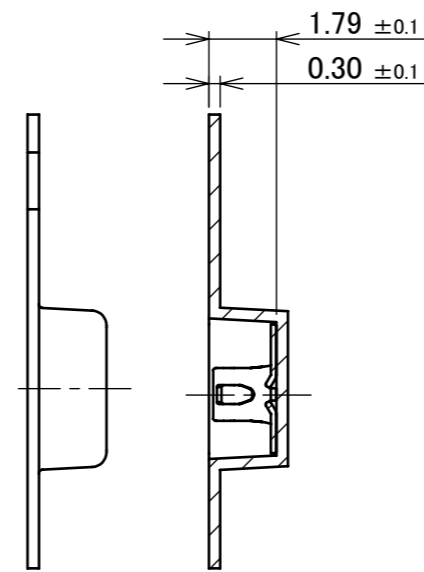
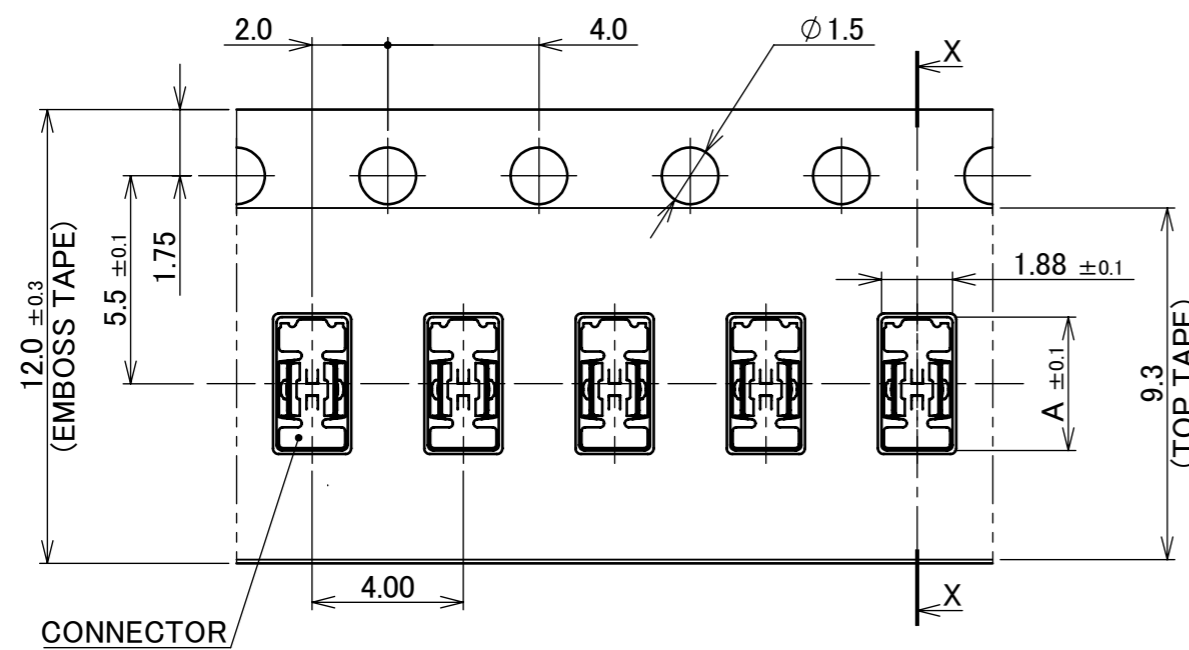
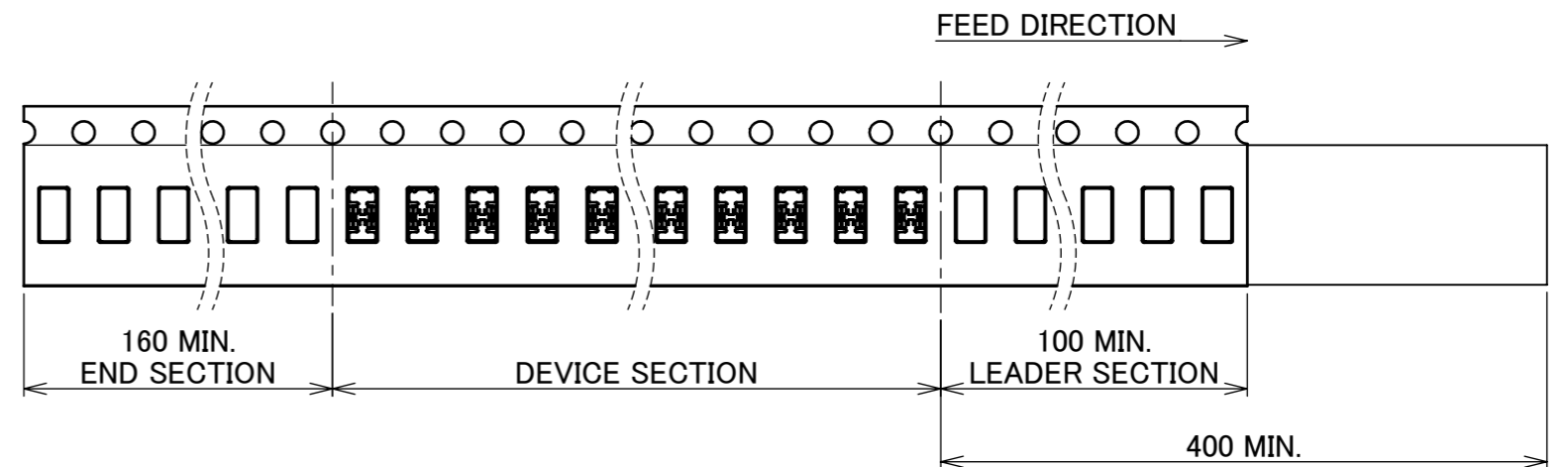
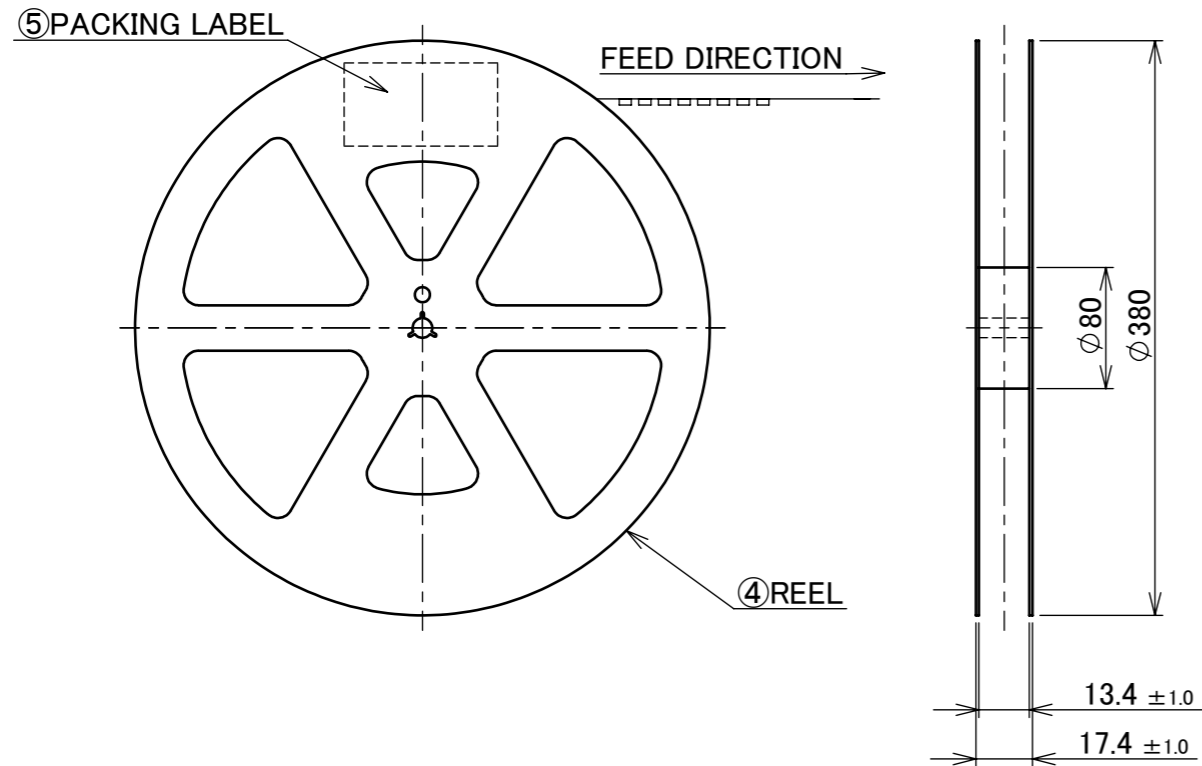

SECT. X-X

NOTES.

- TAPING SPECIFICATION FOLLOWS JIS C 0806 (IEC 60286-3).
- MAKE EMPTY SECTION OF LEADER AND END ON EACH END OF THE TAPE.
- TOP TAPE SHALL NOT STICK OUT FROM EMBOSS TAPE.
- TOP TAPE SHALL NOT COVER FEED HOLE.

NO.	DESCRIPTION	MATERIAL	FINISH , REMARKS
5	PACKING LABEL	-	-
4	REEL	PS	WHITE
3	TOP TAPE	PET TRANSPARENCY	-
2	EMBOSS TAPE	PS TRANSPARENCY	-

ANGLE	±2°	6 OVER 30 MAX.	±0.3	PROJECTION	SERIES No.	CUSTOMER COPY					
6 MAX.	±0.2	30 OVER 120 MAX.	±0.5		R0	I-PEX					
GENERAL TOLERANCE.				TITLE	MP-A04						
DWG.	DATE			DWG. No.					3224	SCALE	X:1
CHK.				DWG. No.					3224	UNIT	mm
APP.				DWG. No.		3224	SIZE	A3			
				DWG. No.		3224	SHEET	7/7			
				DWG. No.		3224	REV.	6			