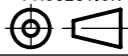

NOTE.
1. RECOMMENDED VACUUM NOZZLE SIZE: $\Phi 0.5$

1	MP-A01	PHOSPHOR BRONZE	CONTACT PART Sn 1.50 μ m MIN. OVER Ni 1.00 μ m MIN. SOLDERING PART Sn 1.00 μ m MIN. OVER Ni 0.50 μ m MIN.
NO.	DESCRIPTION	MATERIAL	FINISH , REMARKS

5	Z211214	H.T	2021/10/05	M.T	ANGLE	$\pm 2^\circ$	6 OVER 30 MAX.	± 0.3	PROJECTION 	SERIES No. R0	CUSTOMER COPY	
4	Z181262	M.N	2018/09/27	Ken	6 MAX.	± 0.2	30 OVER 120 MAX.	± 0.5				
3	Z180775	M.N	2018/06/15	Ken	GENERAL TOLERANCE.				TITLE MP-A 01	SCALE 20:1	UNIT mm	I-PEX
2	Z180659	S.K	2018/06/05	Ken	DWG.	DATE						
1	Z170702	M.N	2017/06/16	Ken	T.Hirakawa		2014/10/10					
0	Z141169	TAK	2014/10/10		CHK.	K.Yotsutani						
REV.	ECN	BY	DATE	APP.	APP.	T.Takano		DWG. No.	3096	SIZE	SHEET	REV.
REVISION RECORD					T.Takano		3096		A3	1/5	5	

ITEMS	SPECIFICATION
APPLICABLE CONNECTOR PART No.	<ul style="list-style-type: none"> • CABLE CLAMP (3mm) FOR $\Phi 0.81$ COAXIAL CABLE (P/N: 2296-003) • CABLE CLAMP (6mm) FOR $\Phi 0.81$ COAXIAL CABLE (P/N: 2818-0001) • CABLE STRIP (OUTER CONDUCTOR $\Phi 0.85 \pm 0.08$) OF $\Phi 0.95$ COAXIAL CABLE. (*1) • CABLE JACKET (OUTSIDE DIAMETER $\Phi 0.81 \pm 0.05$) OF $\Phi 0.81$ COAXIAL CABLE (*2) • CABLE JACKET (OUTSIDE DIAMETER $\Phi 0.95 \pm 0.05$) OF $\Phi 0.95$ COAXIAL CABLE (*1) *1...RF-MF5023 (NISSEI ELECTRIC CO., LTD.) *2...BD-17661 (BANDO DENSEN CO., LTD.)
OPERATING TEMPERATURE	233~358 K (-40°C~+85°C)
OPERATING HUMIDITY	85% MAX. (NON-CONDENSING)
CONTACT RESISTANCE	INITIAL: 70 mohm MAX. / AFTER TEST: 70 mohm MAX.
DURABILITY	5 CYCLES
MATING FORCE (INITIAL / AFTER TEST)	INITIAL: 25 N MAX. / AFTER TEST: 25 N MAX.
UNMATING FORCE (INITIAL / AFTER TEST)	INITIAL: 3 N MIN. / AFTER TEST: 1.5 N MIN.
PRODUCT SPECIFICATION	PRS-2048
TEST REPORT	TR-14139
PACKING STANDARD	PST-14022
INSTRUCTION MANUAL	HIM-14011
APPEARANCE CRITERIA No.	QLS-A***

ANGLE	$\pm 2^\circ$	6 OVER 30 MAX.	± 0.3	PROJECTION 	SERIES No. R0	CUSTOMER COPY		
6 MAX.	± 0.2	30 OVER 120 MAX.	± 0.5					
GENERAL TOLERANCE.				TITLE MP-A 01	SCALE 20:1	I-PEX		
DWG.	DATE							
CHK.								
APP.								
				DWG. No.	3096	SIZE A3	SHEET 2/5	REV. 5

① $\Phi 0.81$ COAXIAL CABLE WITH 3mm CABLE CLAMP (PART NO. 2296-003)

*A-CONTACT: HOLD & CONTACT, B-CONTACT: DEFORMATION

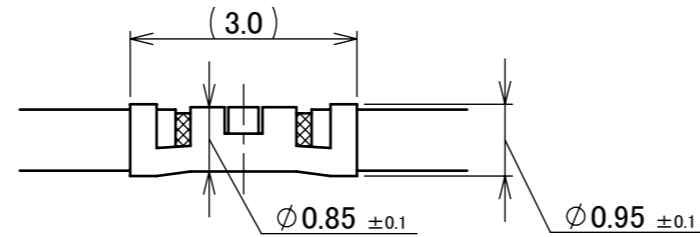

② $\Phi 0.81$ COAXIAL CABLE WITH 6mm CABLE CLAMP (PART NO. 2818-0001)

*A-CONTACT: HOLD & CONTACT, B-CONTACT: NOT CONTACT

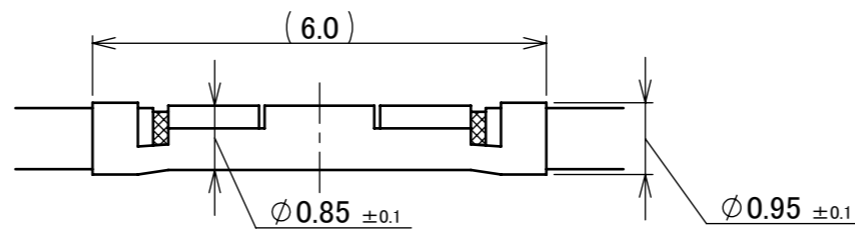

③ STRIPPED $\Phi 0.95$ COAXIAL CABLE

*A-CONTACT: HOLD & CONTACT, B-CONTACT: NOT CONTACT

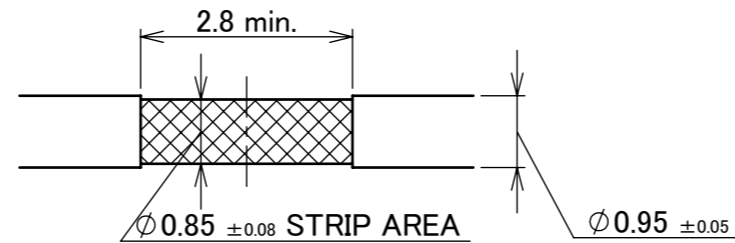

④ UNSTRIPPED $\Phi 0.81$ COAXIAL CABLE (OUTSIDE DIAMETER $\Phi 0.81 \pm 0.05$)

*A-CONTACT: HOLD, B-CONTACT: NOT HOLD

⑤ UNSTRIPPED $\Phi 0.95$ COAXIAL CABLE (OUTSIDE DIAMETER $\Phi 0.95 \pm 0.05$)

*B-CONTACT: HOLD, A-CONTACT: DEFORMATION

APPLICABLE CABLE

NOTE.
2. ONLY A SIMILAR CABLE IS REPLACEABLE.

ANGLE	$\pm 2^\circ$	6 OVER 30 MAX.	± 0.3	PROJECTION 	SERIES No. R0	CUSTOMER COPY			
6 MAX.	± 0.2	30 OVER 120 MAX.	± 0.5						
GENERAL TOLERANCE.				TITLE		SCALE	I-PEX		
DWG.	DATE			MP-A 01		20:1			
CHK.						UNIT			
APP.				DWG. No.		mm			
				3096		SIZE	SHEET	REV.	
						A3	3/5	5	

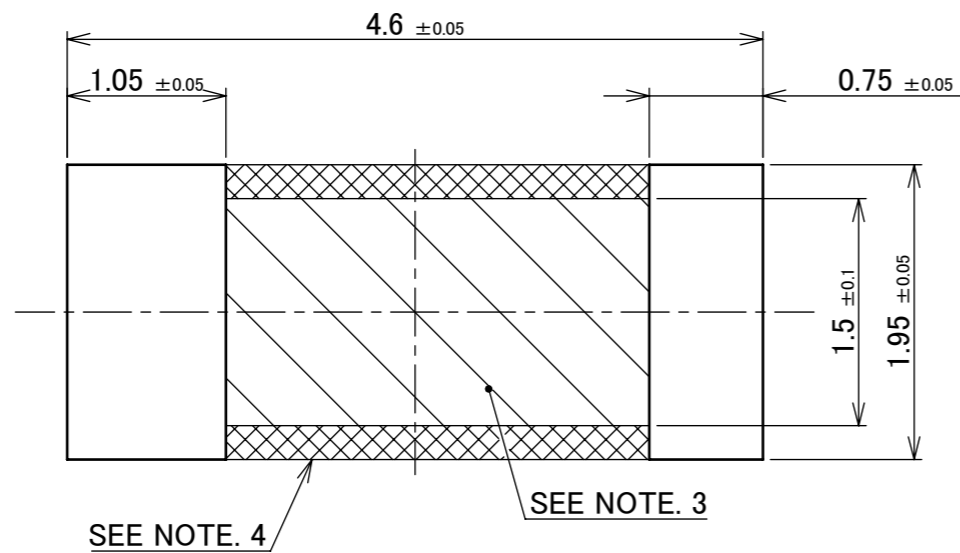

RECOMMENDED FOOTPRINT PATTERN

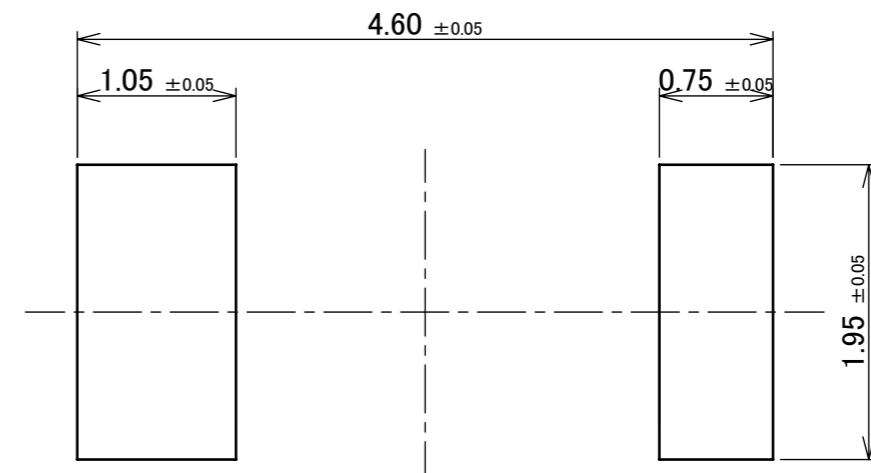

THICKNESS: 0.10mm

METAL MASK

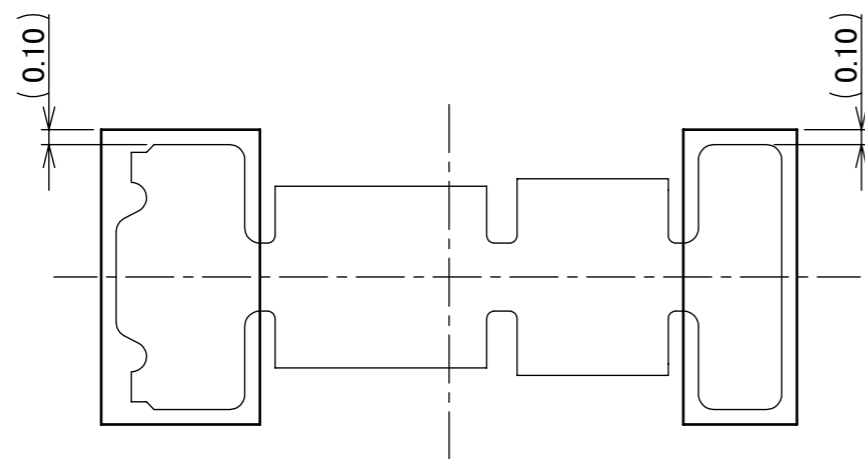

CONNECTOR ON RECOMENDED FOOTPRINT PATTERN

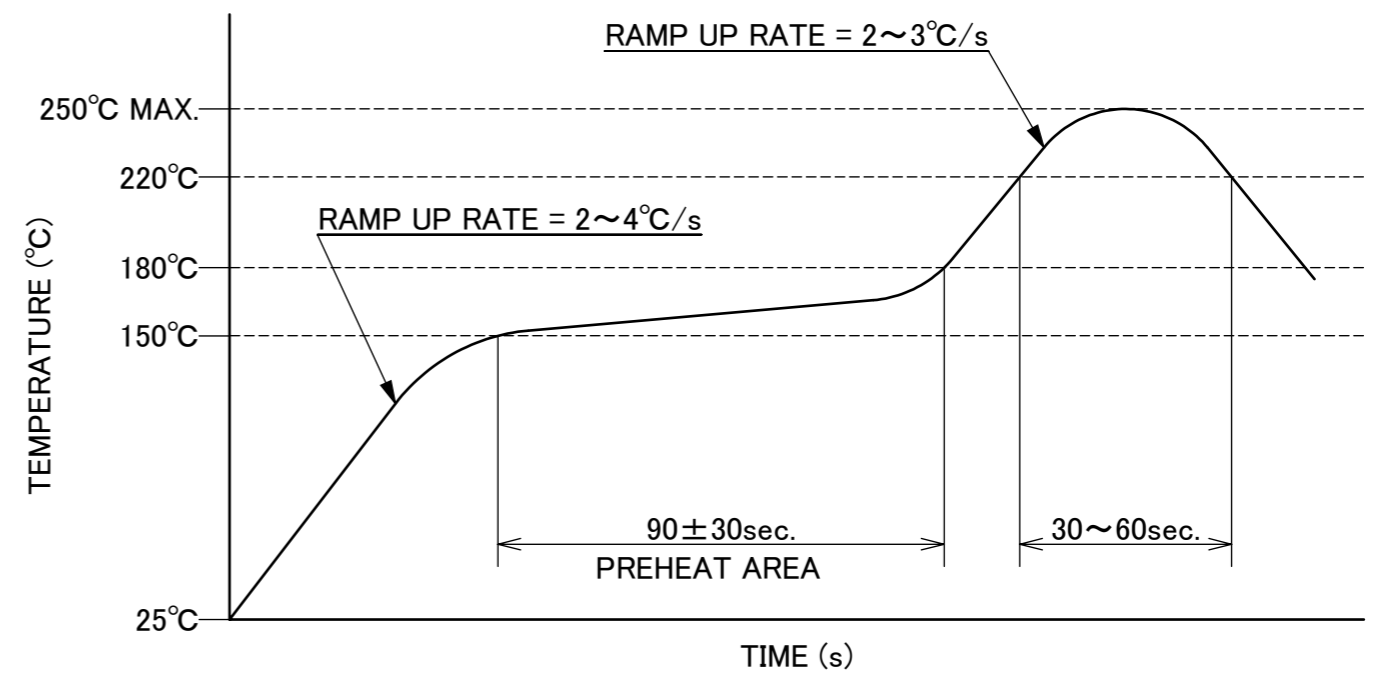

REFLOW TEMPERATURE PROFILE
SENJU METAL INDUSTRY CO., LTD. : M705-SHF(Sn96.5 Ag3.0 Cu0.5)

- NOTES.
3. PATTERN AND RESIST PROHIBITION AREA.
4. THIS AREA CANNOT MOUNT ANOTHER COMPONENTS.

ANGLE	±2°	6 OVER 30 MAX.	±0.3	PROJECTION ⊕	SERIES No. R0	CUSTOMER COPY			
6 MAX.	±0.2	30 OVER 120 MAX.	±0.5						
GENERAL TOLERANCE.				TITLE		SCALE	I-PEX		
DWG.	DATE			MP-A 01		20:1			
CHK.						UNIT			
APP.				DWG. No. 3096		mm			
						SIZE	SHEET	REV.	
						A3	4/5	5	

PART NO.	QTY. PER EMOSS REEL (PIECES / REEL)	QTY. PER PACKING CARTON (REELS / CARTON)
3096-0001	10,000 / REEL	10 REELS / CARTON = 100,000

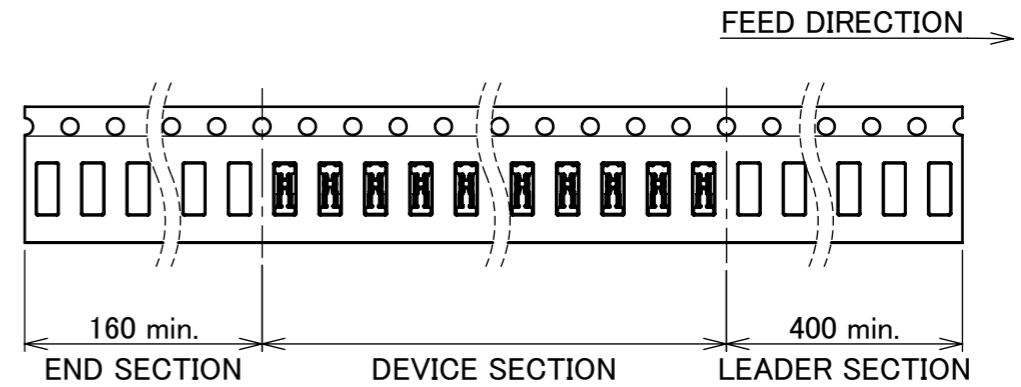
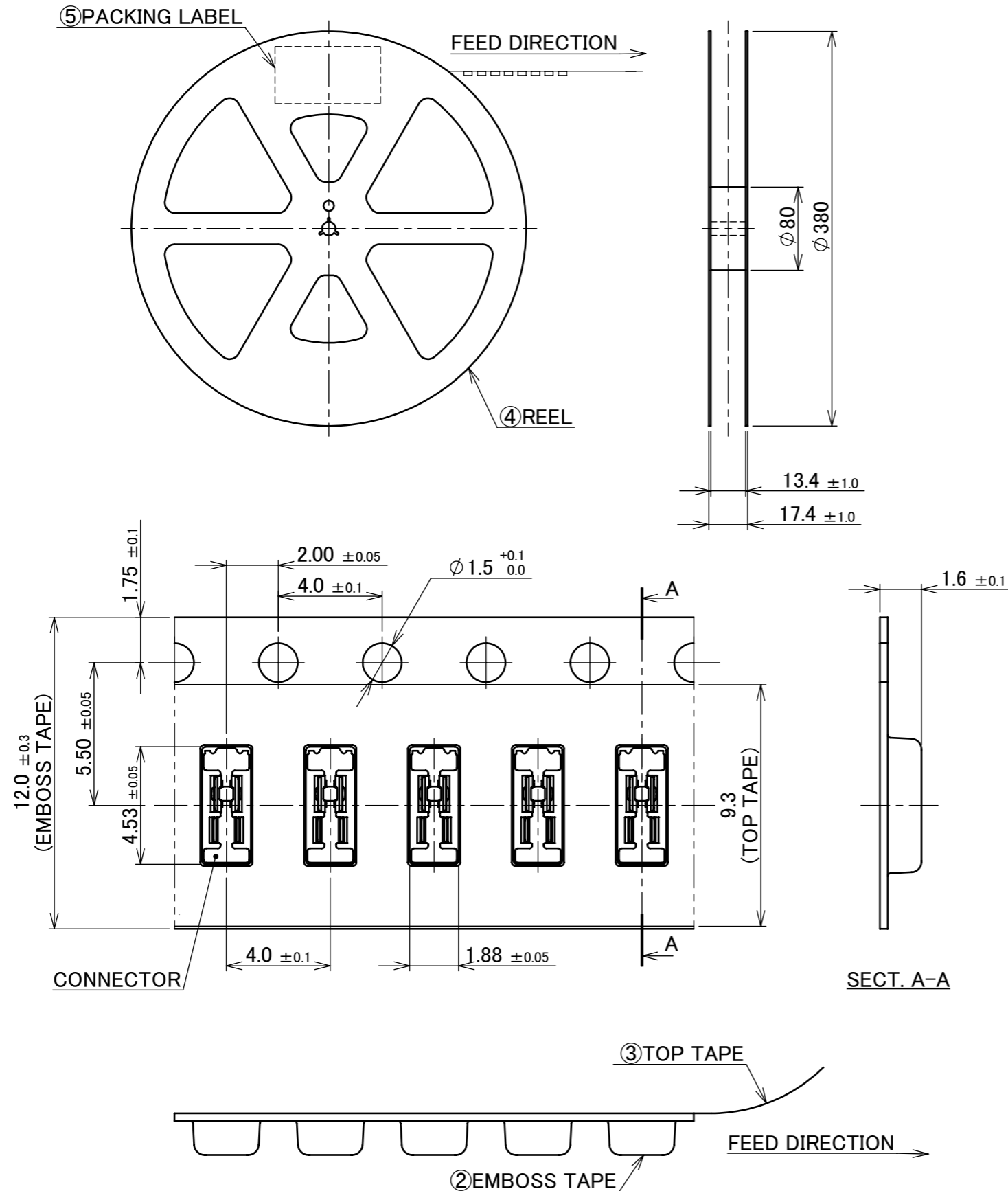

NOTES.

5. TAPING SPECIFICATION FOLLOWS JIS C 0806 (IEC 60286-3).
6. MAKE EMPTY SECTION OF LEADER AND END ON EACH END OF THE TAPE.
7. TOP TAPE SHALL NOT STICK OUT FROM EMOSS TAPE.
8. TOP TAPE SHALL NOT COVER FEED HOLE.

5	PACKING LABEL	-	-
4	REEL	PS	ANTI-STATIC TYPE BLACK
3	TOP TAPE	PET	ANTI-STATIC TYPE
2	EMBOSS TAPE	PS	ANTI-STATIC TYPE
NO.	DESCRIPTION	MATERIAL	FINISH , REMARKS

ANGLE	±2°	6 OVER 30 MAX.	±0.3	PROJECTION ①	SERIES No. R0	CUSTOMER COPY		
6 MAX.	±0.2	30 OVER 120 MAX.	±0.5					
GENERAL TOLERANCE.				TITLE MP-A 01	SCALE 20:1	I-PEX		
DWG.	DATE							
CHK.								
APP.								
DWG. No.				3096	SIZE A3	SHEET 5/5	REV. 5	