

Recommended P/N 20647-0\*\*E-01

PART No.	Pos.	A	B	C	D
20647-020E-01	20P	9.50	14.90	10.57	14.58
20647-030E-01	30P	14.50	19.90	15.57	19.58
20647-040E-01	40P	19.50	24.90	20.57	24.58
20647-050E-01	50P	24.50	29.90	25.57	29.58
◆ 20647-055E-01	55P	27.00	32.40	28.07	32.08
◆ 20647-060E-01	60P	29.50	34.90	30.57	34.58
◆ 20647-064E-01	64P	31.50	36.90	32.57	36.58
◆ 20647-068E-01	68P	33.50	38.90	34.57	38.58

◆ MEANS NOT AVAILABLE

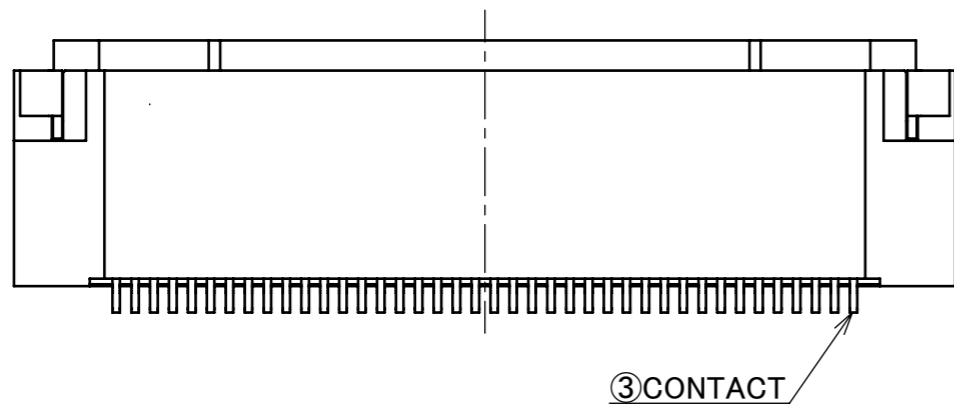
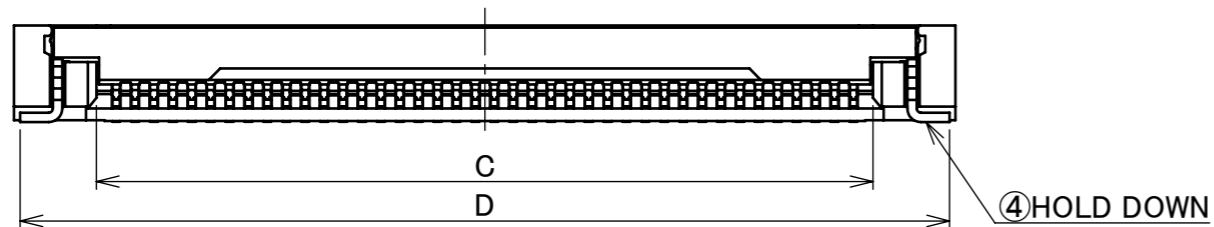
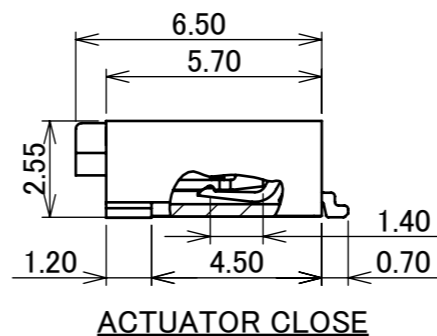
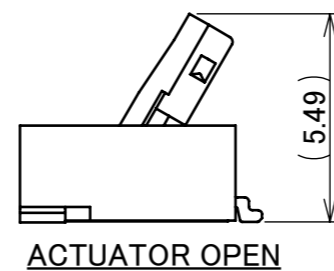
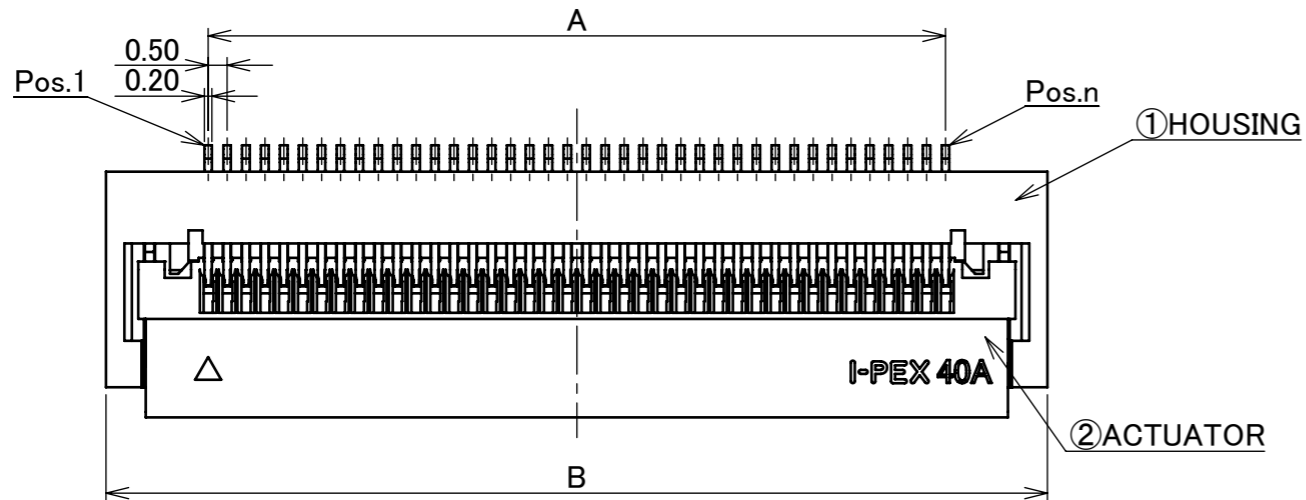
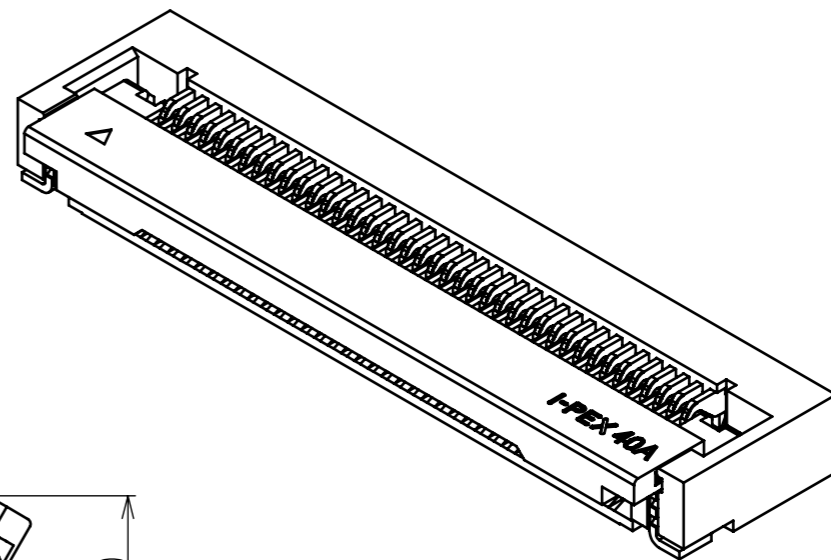

4	HOLD DOWN	COPPER ALLOY	SOLDERING AREA : Au 0.02 μm MIN. OVER Ni 1.00 μm MIN.
3	CONTACT	COPPER ALLOY	CONTACT AREA : Au 0.03 μm MIN. OVER Ni 1.00 μm MIN. SOLDERING AREA : Au 0.03 μm MIN. OVER Ni 1.00 μm MIN.
2	ACTUATOR	LCP	UL94V-0 BLACK
1	HOUSING	LCP	UL94V-0 BEIGE
NO.	DISCRIPTION	MATERIAL	FINISH , REMARKS

11	Z210352	H.K	Apr./02/'21	H.I	ANGLE	±2°	6 OVER 30 MAX.	±0.3	PROJECTION ⊕	SERIES No. R3	CUSTOMER COPY			
10	Z201197	H.K	Nov./19/'20	Y.S	6 MAX.	±0.2	30 OVER 120 MAX.	±0.5						
9	Z191557	H.K	Nov./29/'19	H.I	GENERAL TOLERANCE.				TITLE MINIFLEX® 5-FF	SCALE 5:1	UNIT mm	SHEET 1/5	REV. 11	
8	Z191258	S.Sh	Sept./19/'19	H.I	DWG.	DATE		2014/11/06						
7	Z190078	S.Sh	Jan./18/'19	H.I	T.Ogino									
6	Z180989	H.K	July./30/'18	Y.S	CHK.	J.Tateishi		2014/11/07						
REV.	ECN	BY	DATE	APP.	APP.	E.Kawabe		2014/11/07	DWG. No.	20647	SIZE A3	SHEET 1/5	REV. 11	
REVISION RECORD														

ITEMS	SPECIFICATION
RATING VOLTAGE	50V AC (PER CONTACT)
RATING AMPERAGE (FOR CONTACT)	0.5A DC (PER CONTACT) / 0.35A DC(AVAILABLE FOR ALL PIN)
OPERATING TEMPERATURE	233~378K(-40°C~+105°C)
OPERATING HUMIDITY	90% MAX.(NON-CONDENSING)
CONTACT RESISTANCE (FOR CONTACT)	INITIAL : 40mohm MAX. / AFTER TEST : $\leq$ 20mohm MAX.
INSULATION RESISTANCE	INITIAL : 500Mohm MIN. / AFTER TEST : 500Mohm MIN.
DIELECTRIC WITHSTANDING VOLTAGE	AC200V 1min
DURABILITY	20 CYCLES
CABLE RETENTION FORCE	20P : 8.0N MIN.
	30P : 12.0N MIN.
	40P : 16.0N MIN.
	50P : 20.0N MIN.
	55P : 22.0N MIN.
	60P : 24.0N MIN.
	64P : 25.6N MIN. 68P : 27.2N MIN.
PRODUCT SPECIFICATION	PRS-2039
TEST REPORT	TR-14129
PACKING STANDARD	PST-14086
INSTRUCTION MANUAL	HIM-15007
APPEARANCE CRITERIA No.	QLS-A***

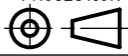
ANGLE	$\pm 2^\circ$	6 OVER 30 MAX.	$\pm 0.3$	PROJECTION 	SERIES No. R3	CUSTOMER COPY		
6 MAX.	$\pm 0.2$	30 OVER 120 MAX.	$\pm 0.5$					
GENERAL TOLERANCE.				TITLE MINIFLEX <sup>®</sup> 5-FF	SCALE 5:1	<b>I-PEX</b>		
DWG.	DATE							
CHK.								
APP.								
				DWG. No.	20647	SIZE A3	SHEET 2/5	REV. 11

Pos.	A	E	F	G	H
20P	9.50	12.00	15.60	12.10	10.50
30P	14.50	17.00	20.60	17.10	15.50
40P	19.50	22.00	25.60	22.10	20.50
50P	24.50	27.00	30.60	27.10	25.50
55P	27.00	29.50	33.10	29.60	28.00
60P	29.50	32.00	35.60	32.10	30.50
64P	31.50	34.00	37.60	34.10	32.50
68P	33.50	36.00	39.60	36.10	34.50

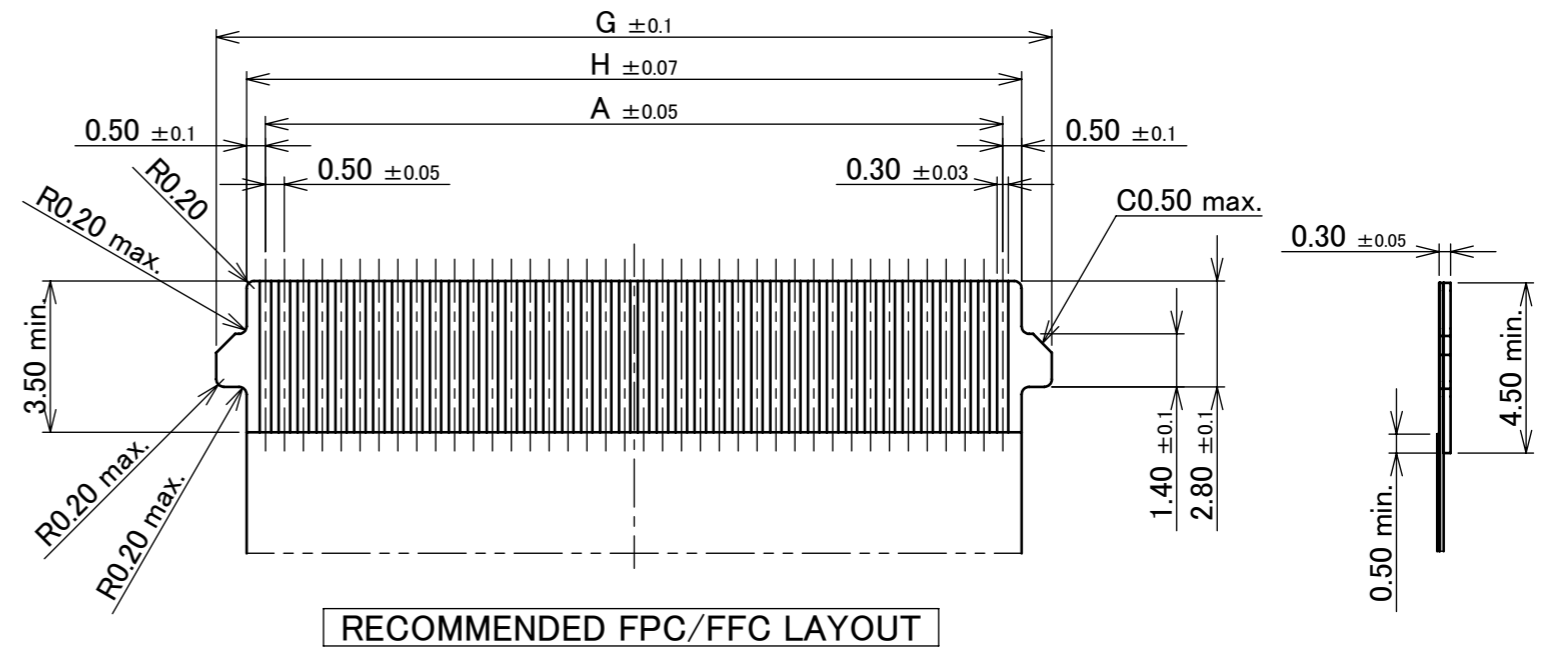
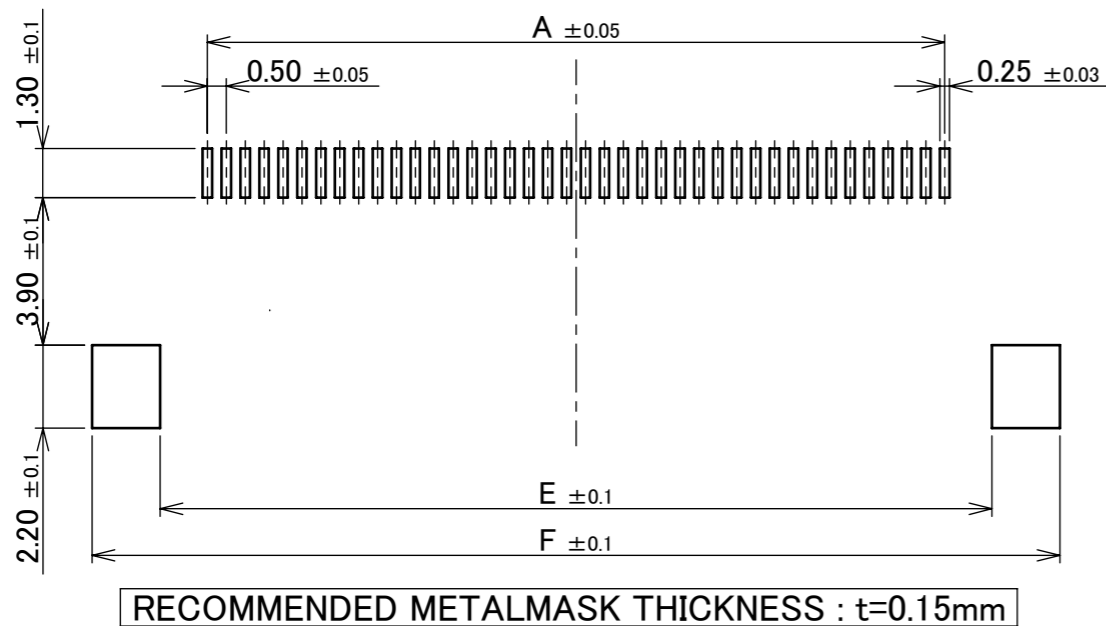
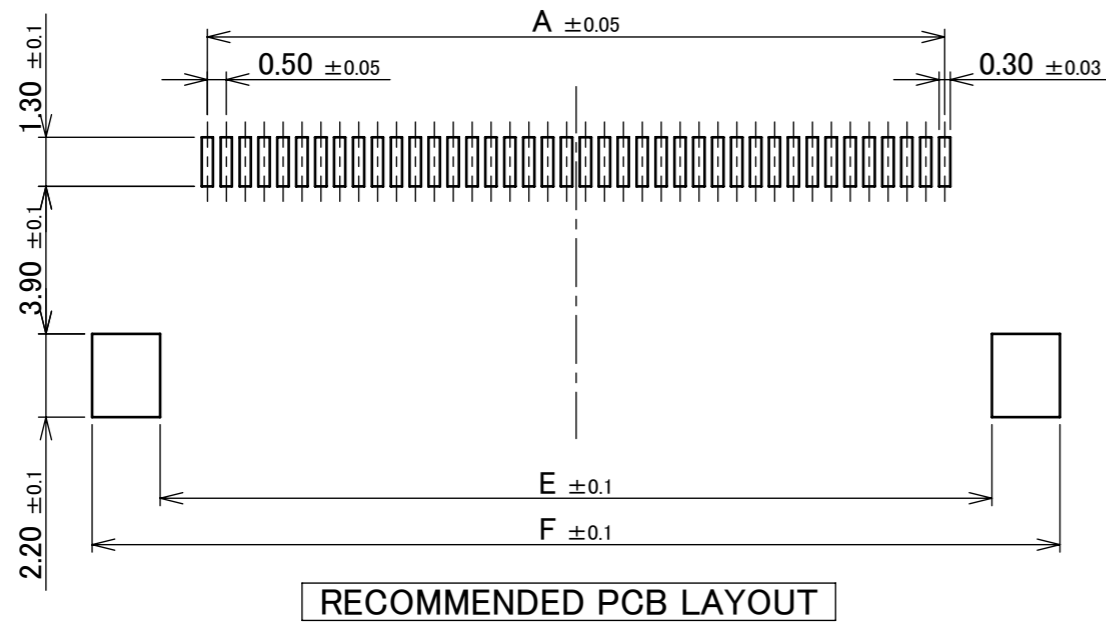

- NOTES  
 1.MATERIAL  
 COVER FILM : PI  
 CONDUCTOR : COPPER  
 BASE FILM : PI  
 STIFFENER : PI  
 ADHESIVE : THERMOSETTING ADHESIVE  
 2.FINISH  
 Au OVER Ni UNDER PLATING

ANGLE	±2°	6 OVER 30 MAX.	±0.3	PROJECTION ⊕	SERIES No. R3	CUSTOMER COPY	
6 MAX.	±0.2	30 OVER 120 MAX.	±0.5				
GENERAL TOLERANCE.				TITLE		SCALE	<b>I-PEX</b>
DWG.	DATE			MINIFLEX® 5-FF		5:1	
CHK.						UNIT	
APP.				DWG. No.		mm	SIZE
				20647		A3	SHEET
						3/5	REV.
							11

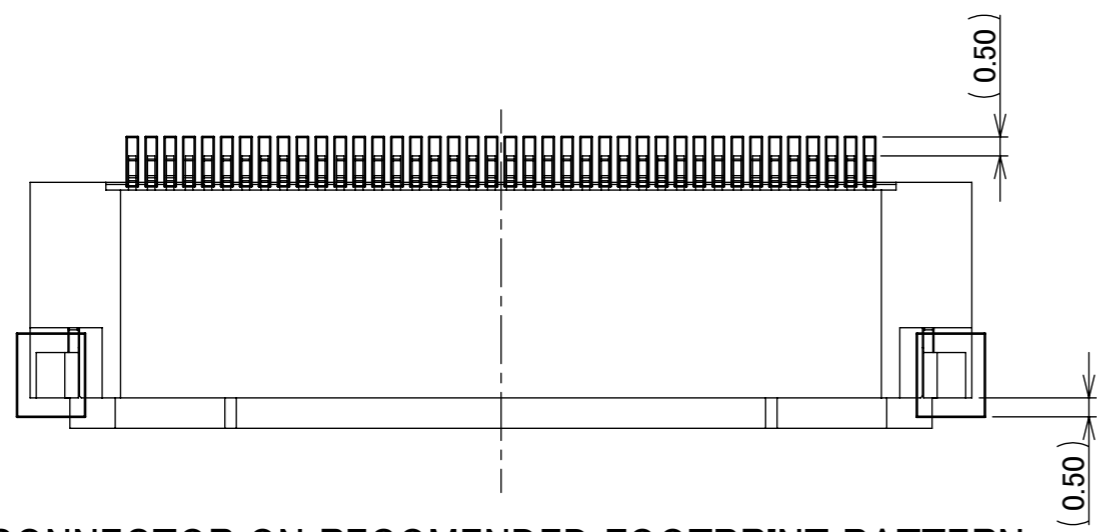

**CONNECTOR ON RECOMENDED FOOTPRINT PATTERN**

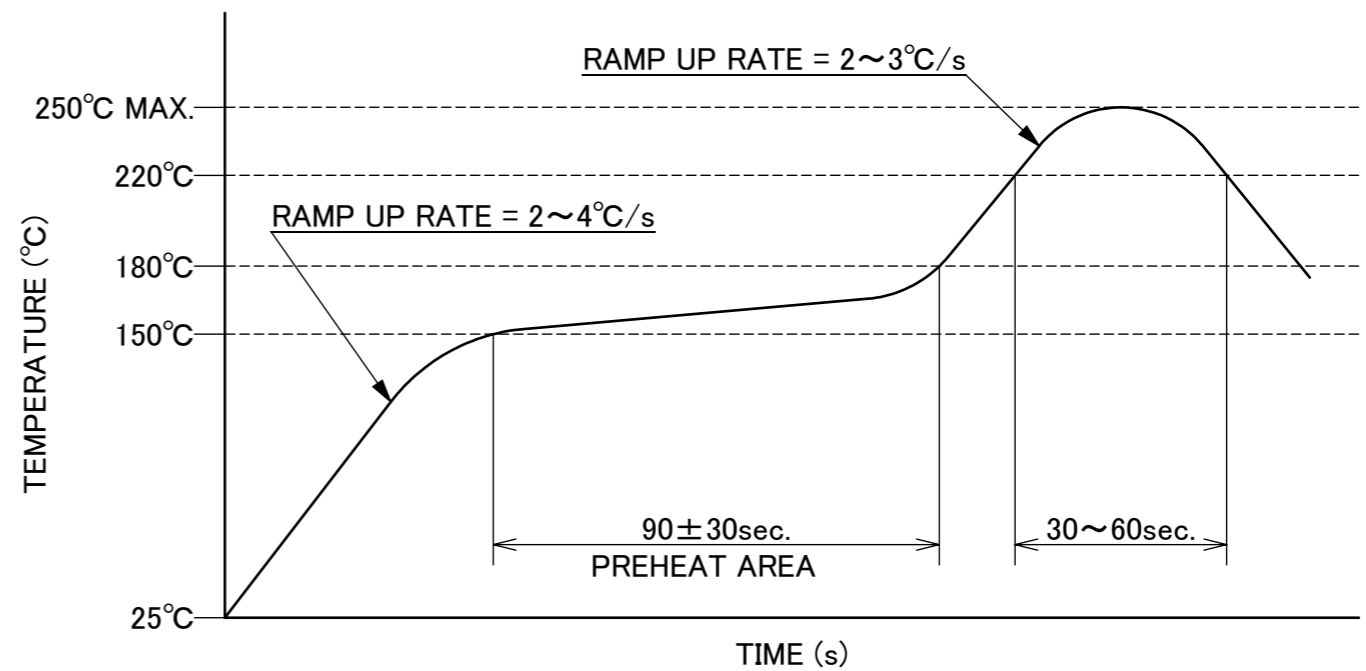

**REFLOW TEMPERATURE PROFILE**  
 SENJU METAL INDUSTRY CO., LTD. : M705-SHF(Sn96.5 Ag3.0 Cu0.5)

ANGLE	±2°	6 OVER 30 MAX.	±0.3	PROJECTION 	SERIES No. R3	CUSTOMER COPY			
6 MAX.	±0.2	30 OVER 120 MAX.	±0.5						
GENERAL TOLERANCE.				TITLE		SCALE			
DWG.	DATE			MINIFLEX® 5-FF		5:1			
CHK.						UNIT			
APP.				DWG. No.		mm			
				20647		SIZE	SHEET	REV.	
						A3	4/5	11	

PART NO.	J	K	L	M	N	P	QTY. PER EMBOSS REEL (PIECES / REEL)	QTY. PER PACKING CARTON (REELS / CARTON)
20647-020E-01	24.00	11.50	-	24.00	10.50	15.30	2000 PIECES / REEL	5REELS / CARTON = 10000 PIECES / CARTON
20647-030E-01	32.00	14.20	28.40	32.00	15.50	20.30		4REELS / CARTON = 8000 PIECES / CARTON
20647-040E-01	44.00	20.20	40.40	44.00	20.50	25.30		3REELS / CARTON = 6000 PIECES / CARTON
20647-050E-01	44.00	20.20	40.40	44.00	25.50	30.30		
◆ 20647-055E-01	44.00	20.20	40.40	44.00	28.00	32.80		2REELS / CARTON = 4000 PIECES / CARTON
◆ 20647-060E-01	56.00	26.20	52.40	56.00	30.50	35.30		
◆ 20647-064E-01	56.00	26.20	52.40	56.00	32.50	37.30		
◆ 20647-068E-01	56.00	26.20	52.40	56.00	34.50	39.30		

◆ MEANS NOT AVAILABLE

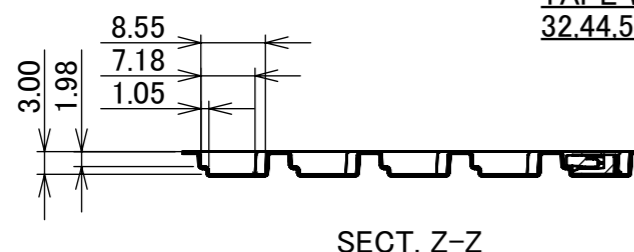
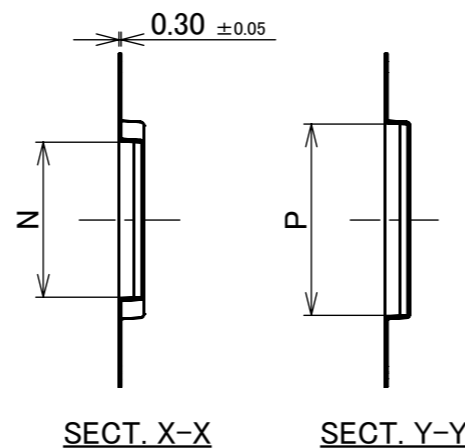
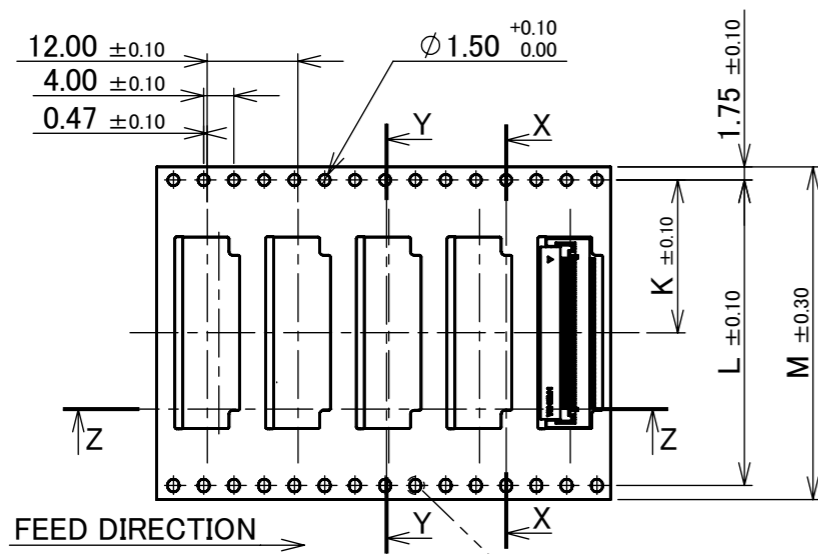
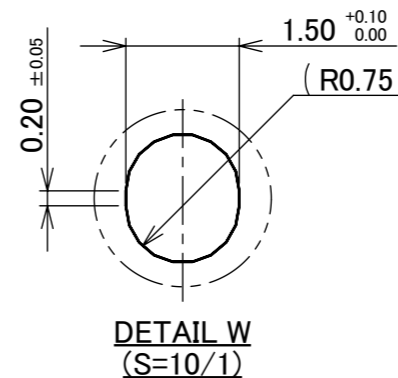
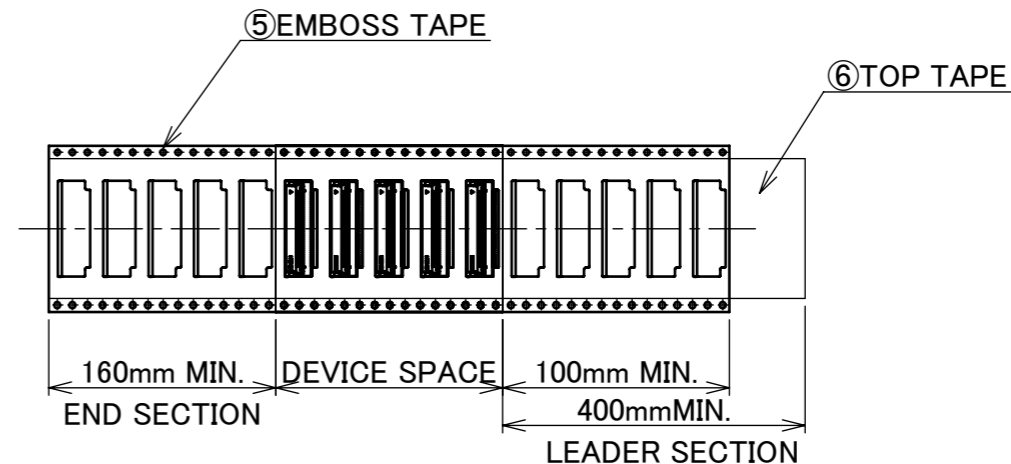
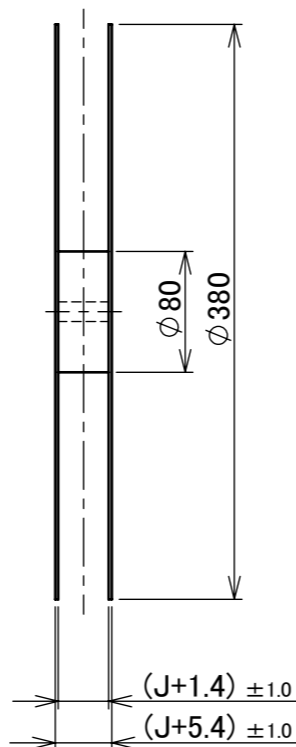
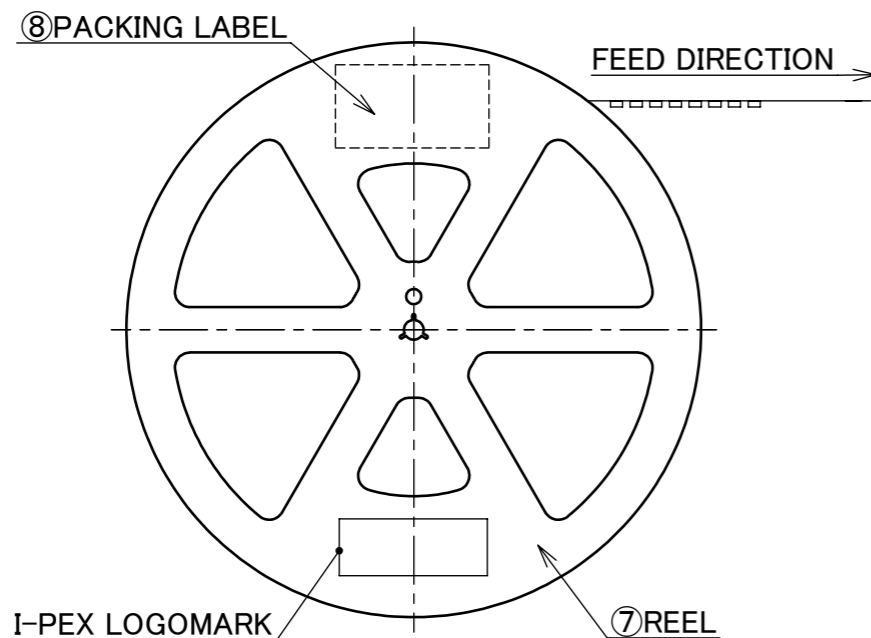

NOTES.

- TAPING SPECIFICATION FOLLOWS JIS C 0806 (IEC 60286-3).
- MAKE EMPTY SECTION OF LEADER AND END ON EACH END OF THE TAPE.
- TOP TAPE SHALL NOT STICK OUT FROM EMBOSS TAPE.
- TOP TAPE SHALL NOT COVER FEED HOLE.

NO.	DISCRIPTION	MATERIAL	FINISH , REMARKS
8	PACKING LABEL	-	-
7	REEL	PS	BLACK
6	TOP TAPE	PET t=0.062 TRANSPARENCY	ANTI-STATIC TYPE
5	EMBOSS TAPE	PS t=0.3 TRANSPARENCY	ANTI-STATIC TYPE

ANGLE	±2°	6 OVER 30 MAX.	±0.3	PROJECTION	SERIES No.	CUSTOMER COPY			
6 MAX.	±0.2	30 OVER 120 MAX.	±0.5		R3				
GENERAL TOLERANCE.				TITLE	MINIFLEX® 5-FF		SCALE	5:1	
DWG.	DATE					UNIT	mm		
CHK.						SIZE	SHEET	REV.	
APP.				DWG. No.	20647	A3	5/5	11	