

PART NO.
30007-200T-03F

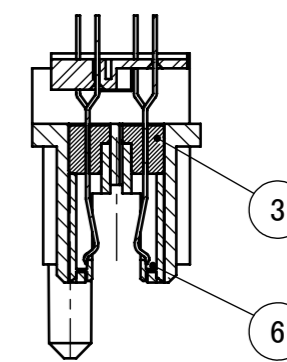

RoHS Compliant

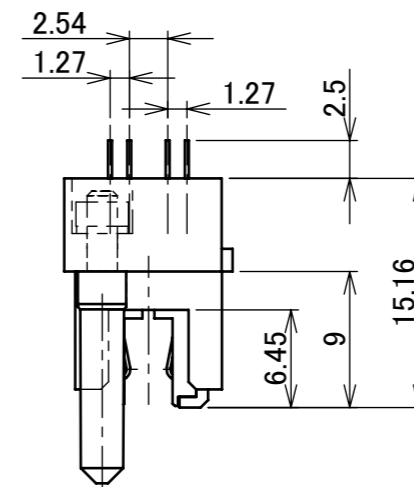
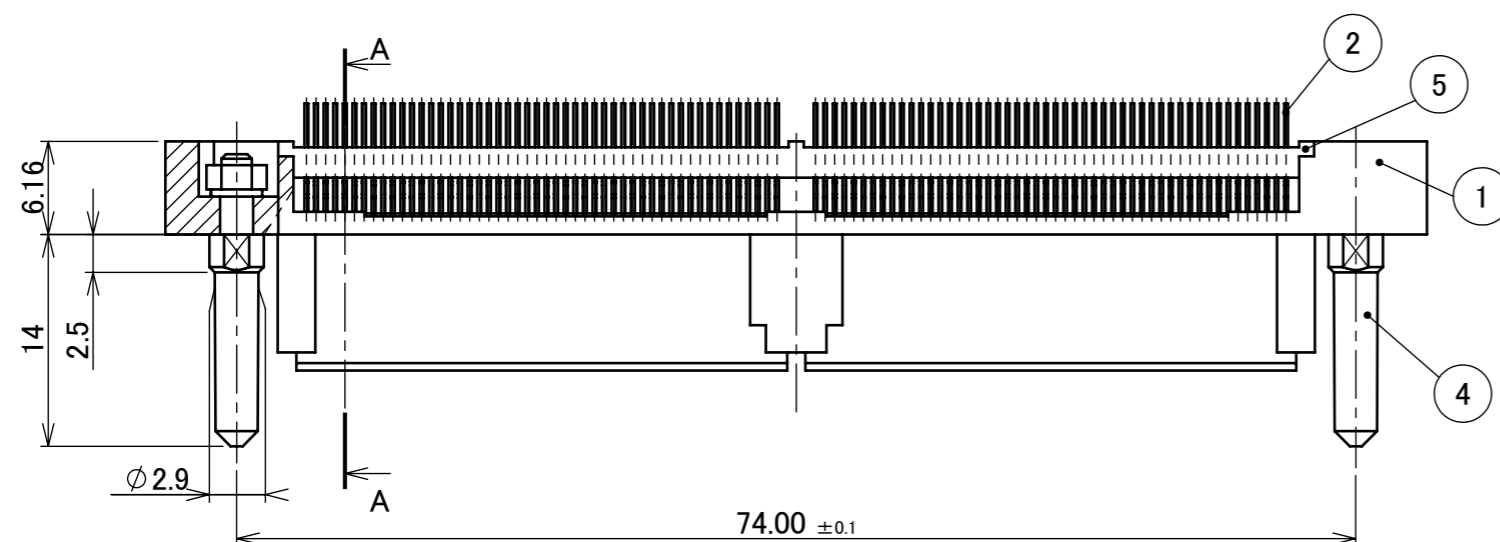

SECT. A-A

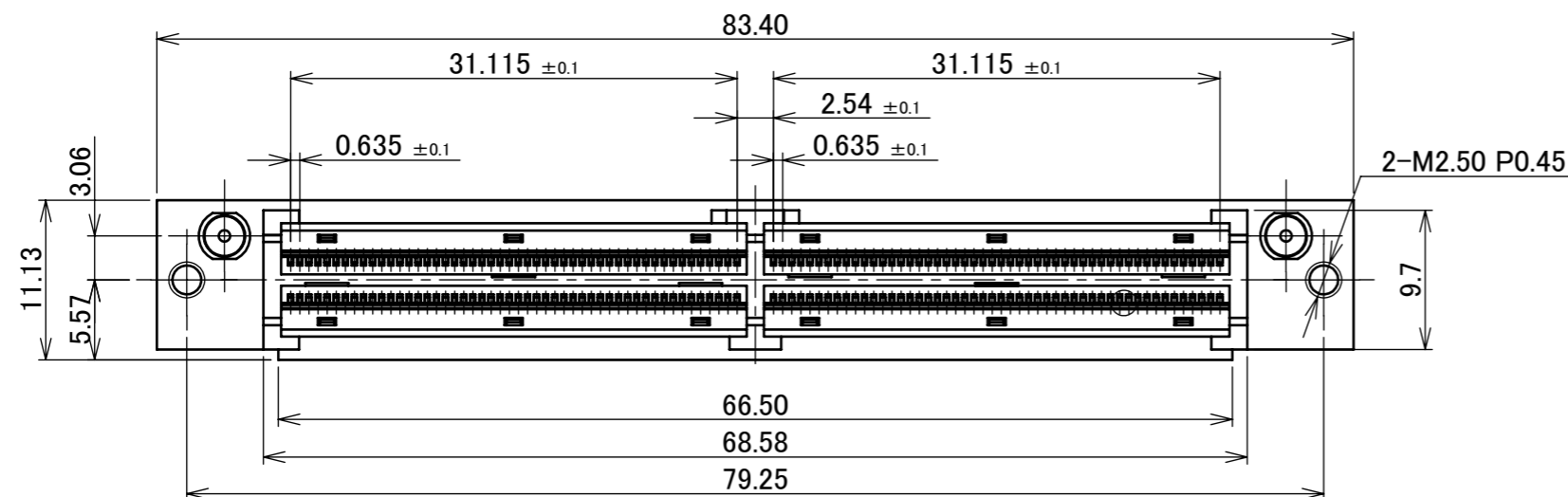

6	CONTACT GUIDE	PPS	BLACK UL94V-0
5	LOCATOR PLATE	PA	BLACK UL94V-0
4	GUIDE PIN	STEEL	Ni PLATING
3	RECE INSULATOR	PPS	BLACK UL94V-0
2	RECE CONTACT	COPPER ALLOY	CONTACT PART Au FLASH OVER Pd-Ni SOLDER TAIL Au FLASH
1	RECE SHELL	Zn ALLOY	Ni OVER Cu PLATING
NO.	DISCRIPTION	MATERIAL	FINISH , REMARKS

15	Z220241	M.H	Mar./18/'22	Y.H	ANGLE	±2°	6 OVER 30 MAX.	±0.3	PROJECTION ⊕	SERIES No. R15	CUSTOMER COPY	
14	Z191328	IMI	Oct./01/'19	Y.S	6 MAX.	±0.2	30 OVER 120 MAX.	±0.5				
13	Z180838	R.H	June/28/'18	TAK	GENERAL TOLERANCE.			TITLE MINIDOCK CONNECTOR VERTICAL RECEPTACLE	SCALE	I-PEX		
12	Z170542	R.H	May/12/'17	M.T	DWG.	E.Kawabe	DATE		1994/11/11		2:1	
11	Z06363	J.O	Aug/02/'06	E.K	CHK.	T.Harada					UNIT	
10	Z06107	J.O	Mar/23/'06	E.K	APP.	K.Katabuchi					mm	
REV.	ECN	BY	DATE	APP.	REVISION RECORD			DWG. No.	30007	SIZE	SHEET	REV.
										A3	1/5	15

ITEMS	SPECIFICATION
RATING VOLTAGE	250V AC (PER CONTACT PIN)
RATING AMPERAGE (FOR CONTACT)	0.5A AC/DC (PER CONTACT PIN)
OPERATING TEMPERATURE	208~358K(-65°C~+85°C)
OPERATING HUMIDITY	85% MAX.(NON-CONDENSING)
CONTACT RESISTANCE (FOR CONTACT)	INITIAL : 70mohm MAX. / AFTER TEST : \triangle 25mohm MAX.
INSULATION RESISTANCE	INITIAL : 10,000Mohm MIN. / AFTER TEST : 1,000Mohm MIN.
DIELECTRIC WITHSTANDING VOLTAGE	AC500V 1min
DURABILITY	5,000 CYCLES
MATING FORCE (INITIAL)	0.9N/pos. MAX.
UNMATING FORCE (AFTER TEST)	0.059N/pos. MIN.
COPLANARITY	-
PRODUCT SPECIFICATION	PRS-1011
TEST REPORT	TR-9020
PACKING STANDARD	300-030
INSTRUCTION MANUAL	-
APPEARANCE CRITERIA No.	QLS-A***

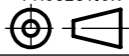
ANGLE	$\pm 2^\circ$	6 OVER 30 MAX.	± 0.3	PROJECTION 	SERIES No. R15	CUSTOMER COPY		
6 MAX.	± 0.2	30 OVER 120 MAX.	± 0.5					
GENERAL TOLERANCE.				TITLE MINIDOCK CONNECTOR VERTICAL RECEPTACLE	SCALE	I-PEX		
DWG.	DATE							
CHK.								
APP.								
				DWG. No.	30007	SIZE A3	SHEET 2/5	REV. 15

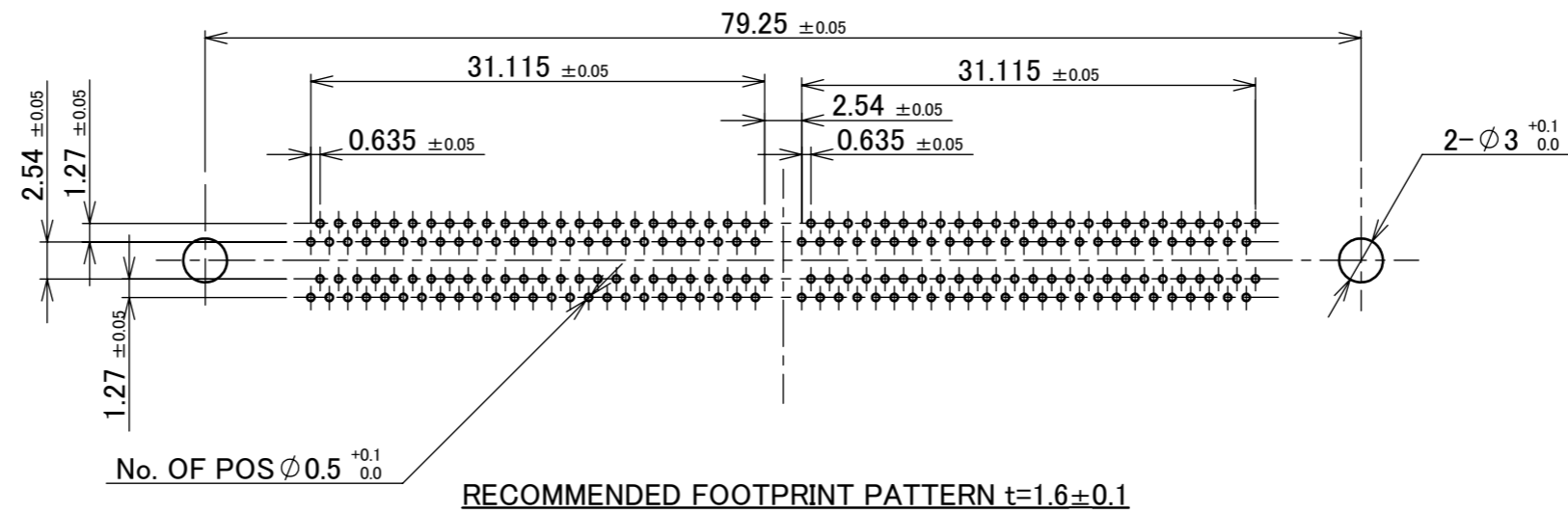

ANGLE	$\pm 2^\circ$	6 OVER 30 MAX.	± 0.3	PROJECTION	SERIES No.	CUSTOMER COPY	
6 MAX.	± 0.2	30 OVER 120 MAX.	± 0.5		R15		
GENERAL TOLERANCE.				TITLE		SCALE	I-PEX
DWG.	DATE			MINIDOCK CONNECTOR VERTICAL RECEPTACLE		2:1	
CHK.						UNIT	
APP.						mm	
				DWG. No.	30007	SIZE	SHEET
						A3	3/5
							REV.
							15

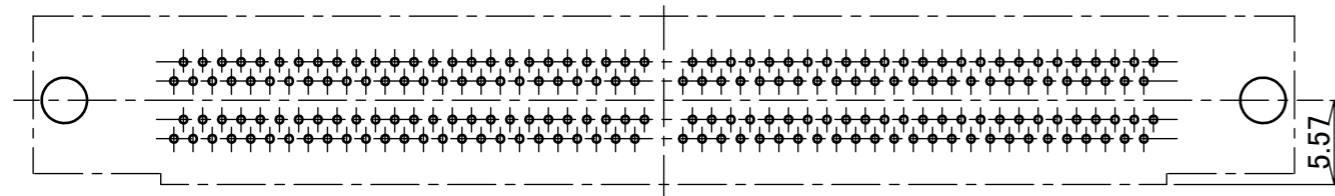

CONNECTOR ON RECOMMENDED FOOTPRINT PATTERN

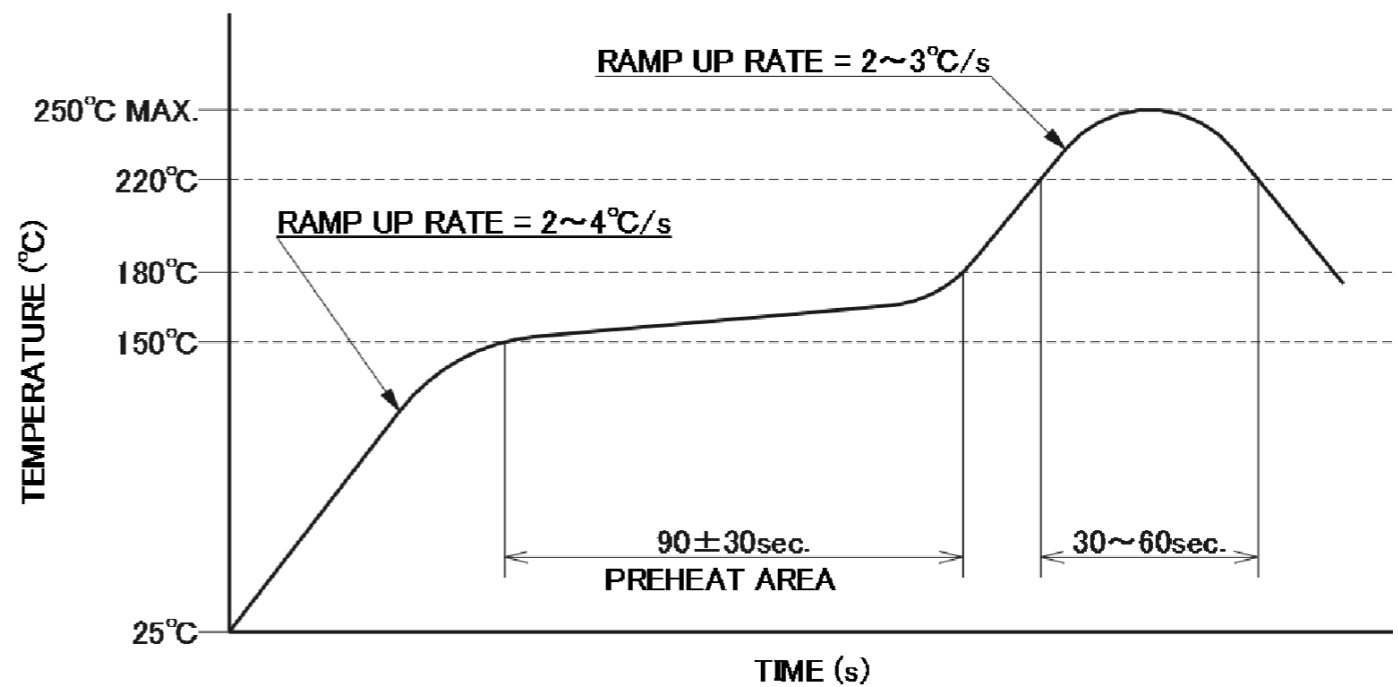

REFLOW TEMPERATURE PROFILE
 SENJU METAL INDUSTRY CO., LTD. : M705-SHF(Sn96.5 Ag3.0 Cu0.5)

ANGLE	±2°	6 OVER 30 MAX.	±0.3	PROJECTION 	SERIES No. R15	CUSTOMER COPY		
6 MAX.	±0.2	30 OVER 120 MAX.	±0.5					
GENERAL TOLERANCE.				TITLE MINIDOCK CONNECTOR VERTICAL RECEPTACLE	SCALE 2:1 UNIT mm			
DWG.	DATE							
CHK.								
APP.								
				DWG. No.	30007	SIZE A3	SHEET 4/5	REV. 15

PART NO.	Pos.	QTY./ TRAY	QTY./ SHIPPING CARTON	QTY./ PACKING CARTON
30007-200T-03F	200P	15	15 × 5 = 75	75 × 4 = 300

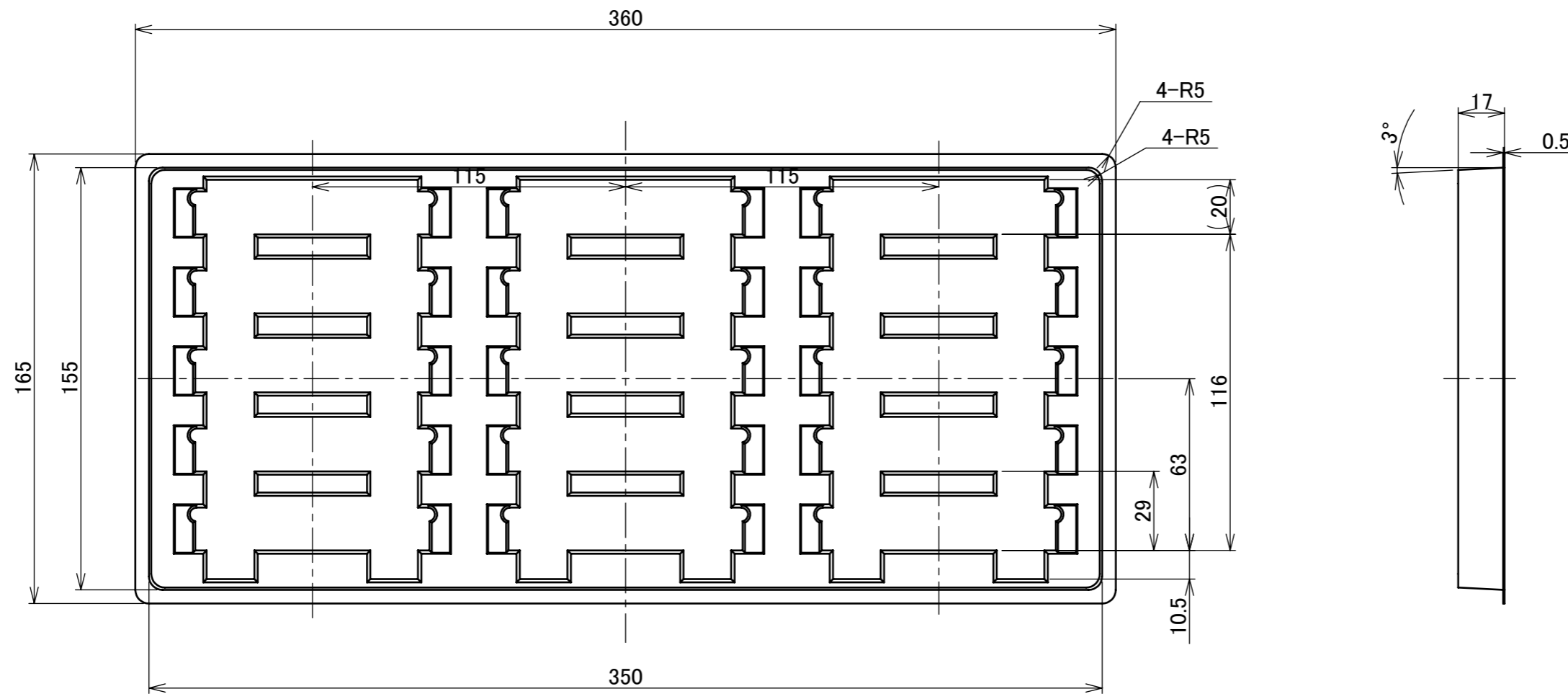

7	TRAY	PVC	-
NO.	DISCRIPTION	MATERIAL	FINISH , REMARKS

ANGLE	±2°	6 OVER 30 MAX.	±0.3	PROJECTION ⊕	SERIES No. R15	CUSTOMER COPY		
	6 MAX.	±0.2	30 OVER 120 MAX.				±0.5	
GENERAL TOLERANCE.				TITLE		SCALE		
DWG.	DATE			MINIDOCK CONNECTOR VERTICAL RECEPTACLE		1;X		
CHK.						UNIT	I-PEX	
APP.						mm		
				DWG. No.	30007	SIZE	SHEET	REV.
						A3	5/5	15

Confidential C

I-PEX Inc.

QKE-DFE06-02 REV.12