

PART No.  
30002-\*\*-0T-\*\*-F

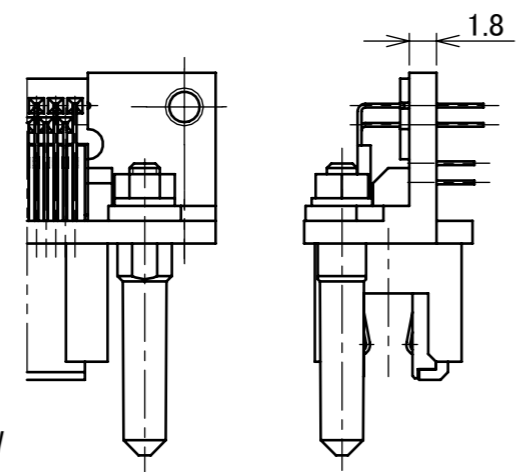

RoHS Compliant

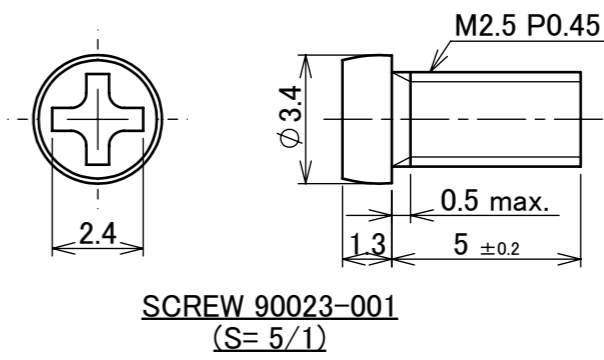
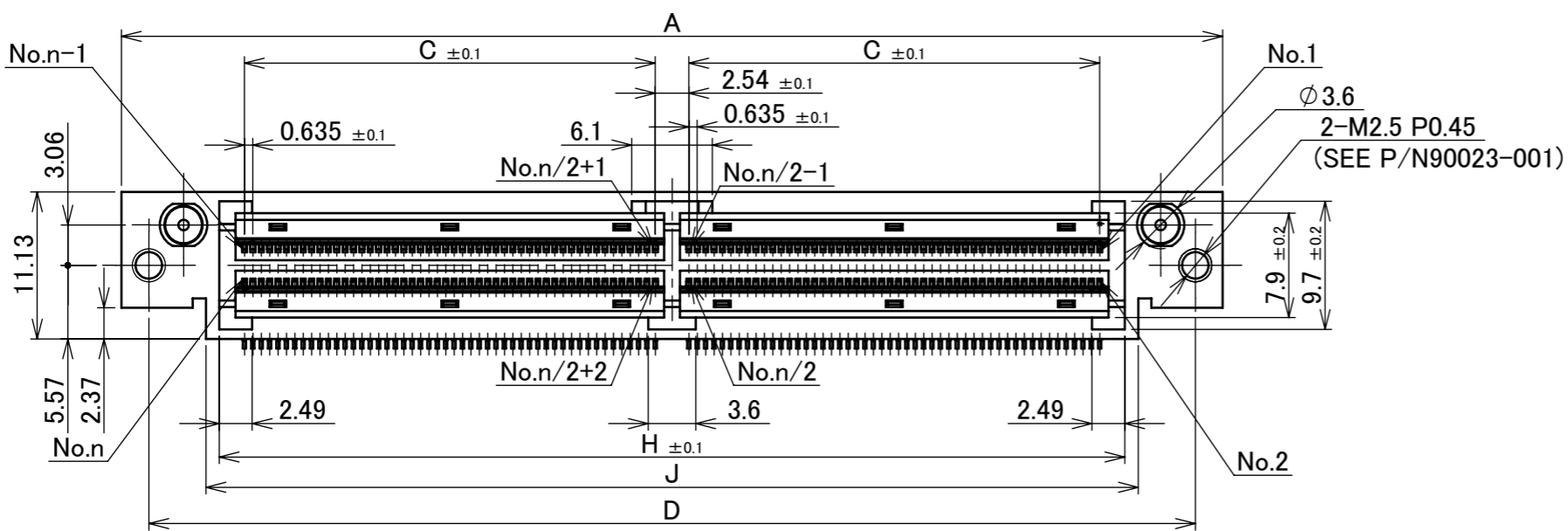
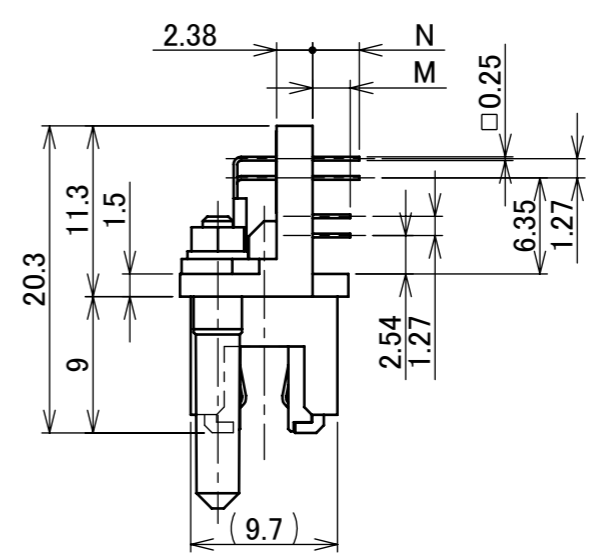
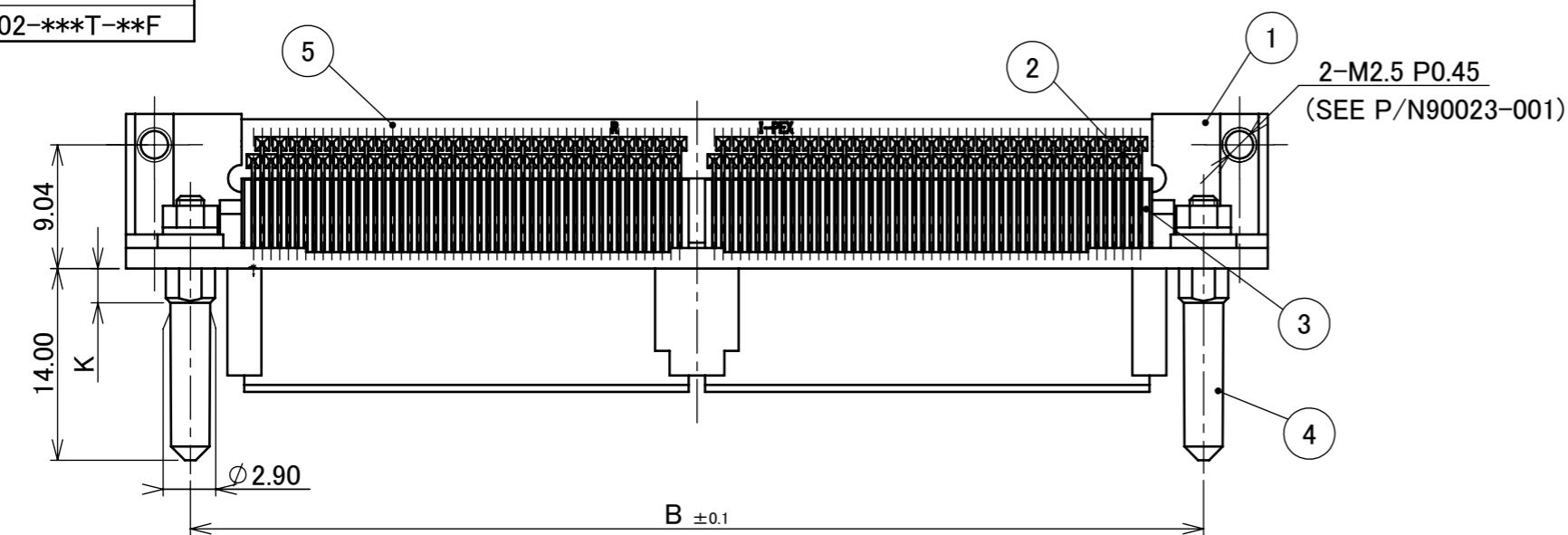

P/N 30002-240T-F.01F

30002-\*\*-0T-\*\*-F  
NONE: WITHOUT SCREW  
01: WITH SCREW  
EXAMPLE  
POS.10 : 100P  
24 : 240P

NOTE  
1. CONNECTOR TO BE MATED: 30001, 30005

| No.             | DISCRIPTION          | MATERIAL     | FINISH, REMARKS  |
|-----------------|----------------------|--------------|--|
| 5               | LOCATOR PLATE        | PA           | BLACK UL94V-0  |
| 4               | GUIDE PIN            | STEEL        | Ni PLATING   |
| 3               | RECEPTACLE INSULATOR | PPS          | BLACK UL94V-0  |
| 2               | RECEPTACLE CONTACT   | COPPER ALLOY | ALL OVER Ni 1.27 μm MIN.<br>CONTACT PART Au 0.05 μm MIN. |
| 1               | RECEPTACLE SHELL     | Zn ALLOY     | Ni PLATING   |
| REVISION RECORD |                      |              |  |
| REV.            | ECN                  | BY           | DATE   |
|                 |                      |              | APP.   |
|                 |                      |              | APP.   |
|                 |                      |              | Y.Fukuda   |

| No. | DISCRIPTION | MATERIAL | FINISH, REMARKS |
|-----|-------------|----------|-----------------|
| 30  | Z230123     | M.H      | Feb./22/'22     |
| 29  | Z220241     | M.H      | Mar./18/'22     |
| 28  | Z191328     | IMI      | Oct./01/'19     |
| 27  | Z190602     | IMI      | May/06/'19      |
| 26  | Z180831     | R.H      | June/27/'18     |
| 25  | Z170967     | R.H      | Aug./23/'17     |

  

| ANGLE  | ±2°  | 6 OVER 30 MAX.   | ±0.3 |
|--------|------|------------------|------|
| 6 MAX. | ±0.2 | 30 OVER 120 MAX. | ±0.5 |

  

| PROJECTION | SERIES No. | TITLE  | SCALE |
|------------|------------|--|-------|
|            | R15        | MINIDOCK<br>CONNECTOR<br>RIGHT ANGLE<br>RECEPTACLE | 2:1   |
|            |            |  | UNIT  |
|            |            |  | mm    |
|            |            |  | SIZE  |
|            |            |  | A3    |
|            |            |  | SHEET |
|            |            |  | 1/5   |
|            |            |  | REV.  |
|            |            |  | 30    |

| ITEMS                            | SPECIFICATION   |
|----------------------------------|---|
| RATING VOLTAGE                   | 250V AC (PER CONTACT PIN)                               |
| RATING AMPERAGE (FOR CONTACT)    | 0.5A AC/DC (PER CONTACT PIN)                            |
| OPERATING TEMPERATURE            | 208~358K(-65°C~+85°C)                                   |
| OPERATING HUMIDITY               | 85% MAX.(NON-CONDENSING)                                |
| CONTACT RESISTANCE (FOR CONTACT) | INITIAL : 70mohm MAX. / AFTER TEST : $\leq$ 25mohm MAX. |
| INSULATION RESISTANCE            | INITIAL : 10,000Mohm MIN. / AFTER TEST : 1,000Mohm MIN. |
| DIELECTRIC WITHSTANDING VOLTAGE  | AC500V 1min   |
| DURABILITY                       | 5,000 CYCLES  |
| MATING FORCE (INITIAL)           | 0.9N/pos. MAX.  |
| UNMATING FORCE (AFTER TEST)      | 0.059N/pos. MIN.  |
| COPLANARITY                      | -   |
| PRODUCT SPECIFICATION            | PRS-1011  |
| TEST REPORT                      | TR-9020   |
| PACKING STANDARD                 | 300-015   |
| INSTRUCTION MANUAL               | -   |
| APPEARANCE CRITERIA No.          | QLS-A***  |

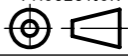
|                    |               |                  |           |   |                   |               |  |  |
|--------------------|---------------|------------------|-----------|---|-------------------|---------------|--|--|
| ANGLE              | $\pm 2^\circ$ | 6 OVER 30 MAX.   | $\pm 0.3$ | PROJECTION<br> | SERIES No.<br>R15 | CUSTOMER COPY |  |  |
| 6 MAX.             | $\pm 0.2$     | 30 OVER 120 MAX. | $\pm 0.5$ |   |                   |               |  |  |
| GENERAL TOLERANCE. |               |                  |           | TITLE<br>MINIDOCK<br>CONNECTOR<br>RIGHT ANGLE<br>RECEPTACLE   | SCALE             | <b>I-PEX</b>  |  |  |
| DWG.               | DATE          |                  |           |   |                   |               |  |  |
| CHK.               |               |                  |           |   |                   |               |  |  |
| APP.               |               |                  |           |   |                   |               |  |  |
| DWG. No.           | 30002         |                  |           | SIZE  | SHEET             | REV.          |  |  |
|                    |               |                  |           | A3  | 2/5               | 30            |  |  |

|                | POS. | A     | B     | C      | D     | H     | J     | K    | M   | N   | P     | S     | NOTE          |
|----------------|------|-------|-------|--------|-------|-------|-------|------|-----|-----|-------|-------|---------------|
| 30002-100T-F   | 100P | 51.65 | 42.25 | 15.24  | 47.50 | 37.35 | 38.85 | 2.50 | 2.8 | 2.8 | 47.52 | 37.55 | WITHOUT SCREW |
| 30002-120T-F   | 120P | 58.00 | 48.60 | 18.415 | 53.85 | 43.70 | 45.20 |      | 2.5 | 3.1 | 53.85 | 43.90 |               |
| 30002-240T-F   | 240P | 96.10 | 86.70 | 37.465 | 91.95 | 81.80 | 83.30 | 5.30 | 2.8 | 2.8 | 47.52 | 37.55 | WITH SCREW    |
| 30002-100T-01F | 100P | 51.65 | 42.25 | 15.24  | 47.50 | 37.35 | 38.85 |      | 2.5 | 3.1 | 53.85 | 43.90 |               |
| 30002-120T-01F | 120P | 58.00 | 48.60 | 18.415 | 53.85 | 43.70 | 45.20 |      | 2.5 | 3.1 | 91.95 | 82.00 |               |
| 30002-240T-01F | 240P | 96.10 | 86.70 | 37.465 | 91.95 | 81.80 | 83.30 |      |     |     |       |       |               |

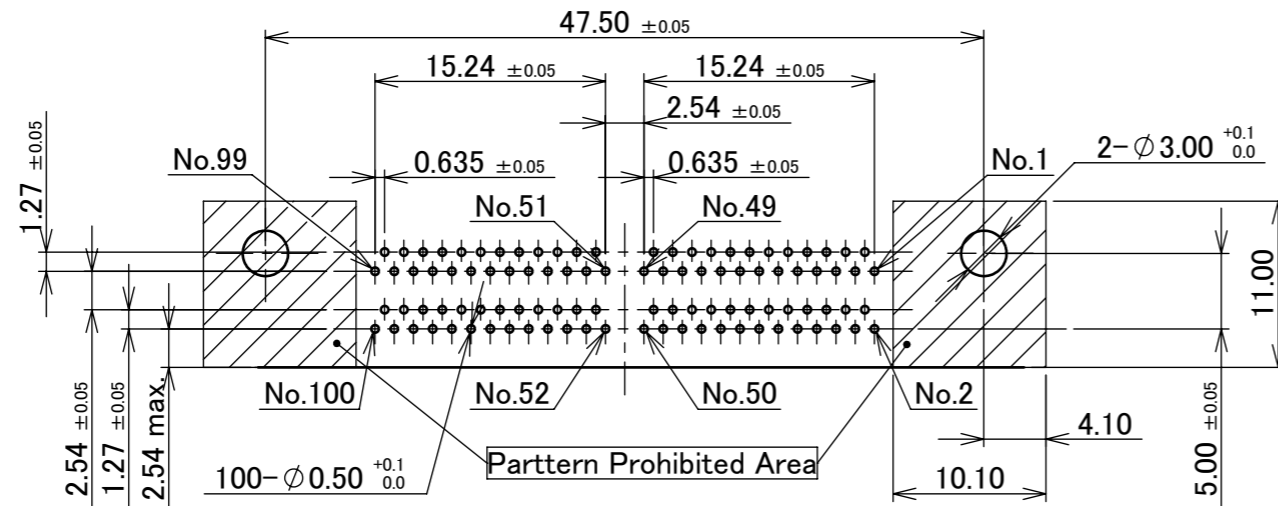

RECOMMENDED FOOTPRINT PATTERN  $t=1.6 \pm 0.1$  (100P ONLY)

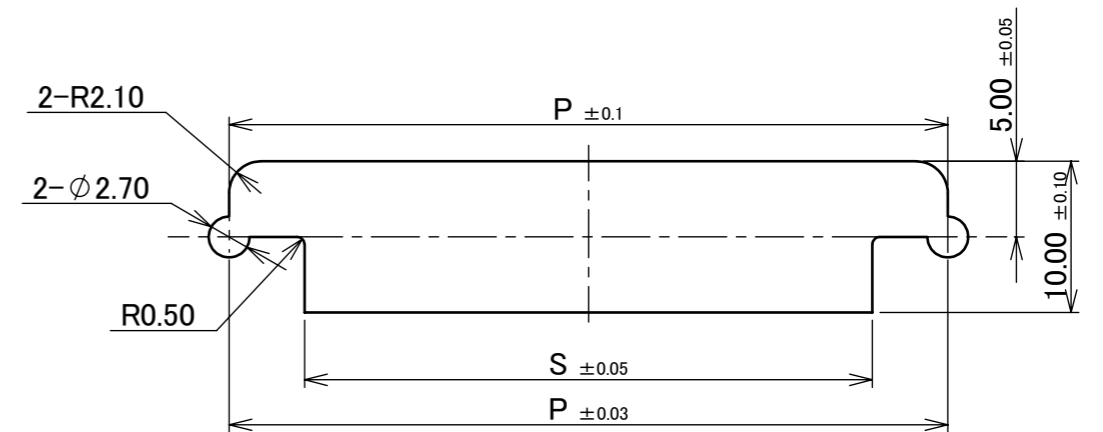

RECOMMENDED OPENING FOR MOUNTING BRACKET

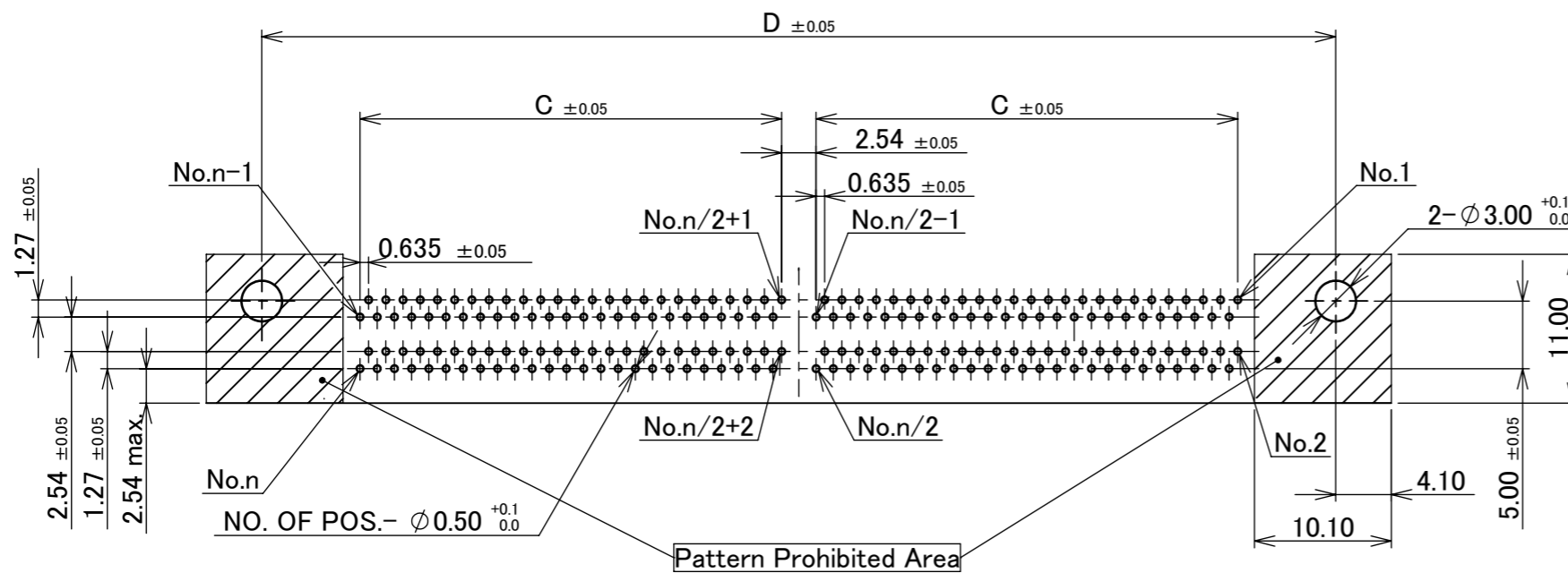

RECOMMENDED FOOTPRINT PATTERN  $t=1.6 \pm 0.1$  (OTHERS)

|                    |               |                |                  |            |            |               |       |
|--------------------|---------------|----------------|------------------|------------|------------|---------------|-------|
| ANGLE              | $\pm 2^\circ$ | 6 OVER 30 MAX. | $\pm 0.3$        | PROJECTION | SERIES No. | CUSTOMER COPY |       |
|                    | 6 MAX.        | $\pm 0.2$      | 30 OVER 120 MAX. | $\pm 0.5$  | R15        |               |       |
| GENERAL TOLERANCE. |               |                |                  |            | TITLE      | SCALE         |       |
| DWG.               | DATE          |                | MINIDOCK         |            |            |               |       |
| CHK.               |               |                | CONNECTOR        |            |            |               |       |
| APP.               |               |                | RIGHT ANGLE      |            |            |               |       |
|                    |               |                |                  | DWG. No.   | 30002      | SIZE          | SHEET |
|                    |               |                |                  |            |            | A3            | 3/5   |
|                    |               |                |                  |            |            |               | REV.  |
|                    |               |                |                  |            |            |               | 30    |

| PART No.       | POS. | QTY./ TRAY | QTY./ SHIPPING CARTON | QTY./ PACKING CARTON |
|----------------|------|------------|-----------------------|----------------------|
| 30002-240T-F   | 240P | 12         | 12 × 5 = 60           | 60 × 4 = 240         |
| 30002-240T-01F |      |            |                       |                      |

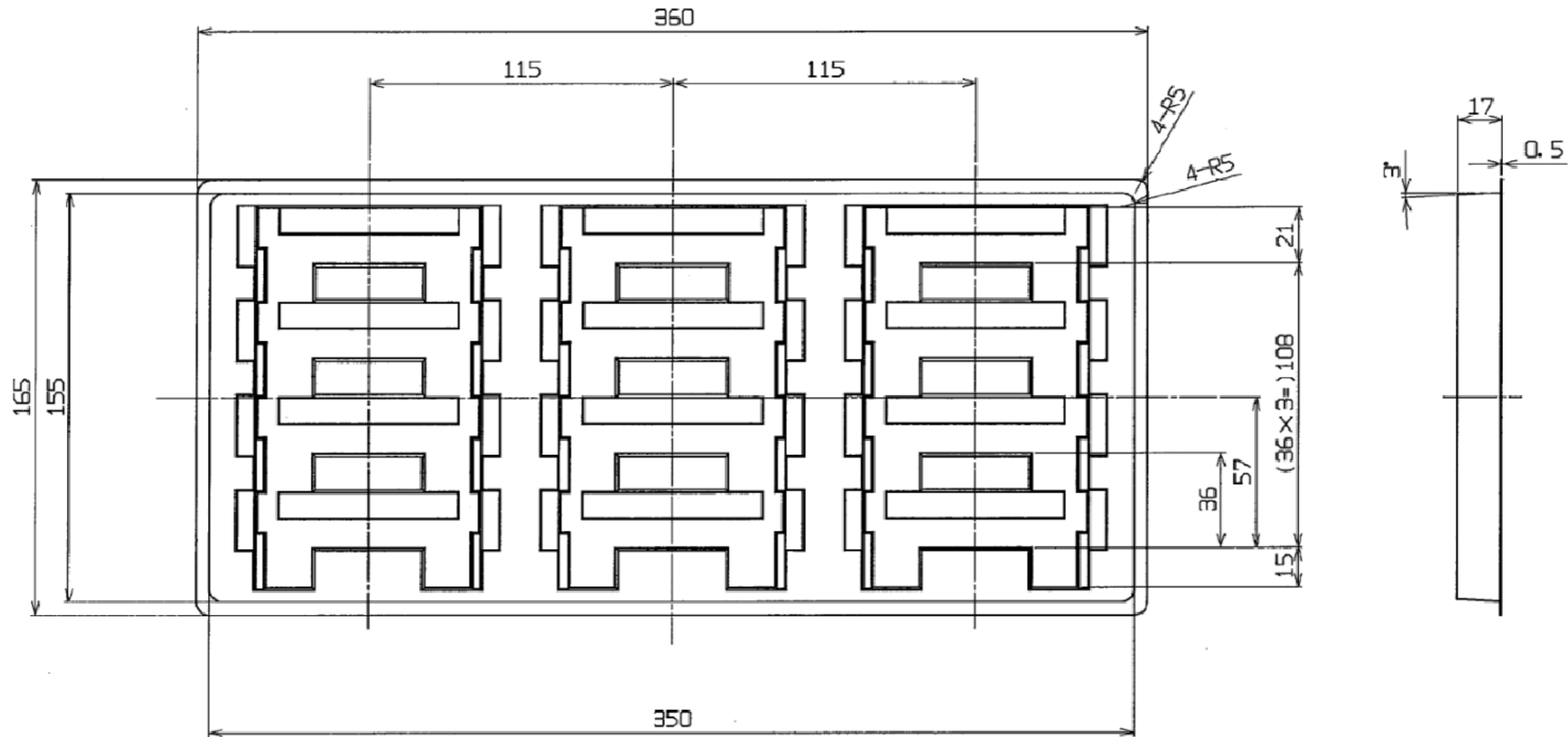

| No.                | DISCRIPTION           | MATERIAL   | FINISH , REMARKS  |
|--------------------|-----------------------|--|-------------------|
| 7                  | TRAY                  | PVC  | -                 |
| ANGLE              | ±2° 6 OVER 30 MAX.    | ±0.3   | PROJECTION<br>⊕ ◁ |
| 6 MAX.             | ±0.2 30 OVER 120 MAX. | ±0.5   |                   |
| GENERAL TOLERANCE. |                       | TITLE  | SCALE             |
| DWG.               | DATE                  | MINIDOCK<br>CONNECTOR<br>RIGHT ANGLE<br>RECEPTACLE | 1:X               |
| CHK.               |                       |  | UNIT              |
| APP.               |                       |  | mm                |
|                    |                       | DWG. No.   | SIZE SHEET REV.   |
|                    |                       | 30002  | A3 4/5 30         |

| PART NO.       | Pos. | QTY./ TRAY | QTY./ SHIPPING CARTON | QTY./ PACKING CARTON |
|----------------|------|------------|-----------------------|----------------------|
| 30002-100T-F   | 100P | 20         | 20 × 5 = 100          | 100 × 4 = 400        |
| 30002-100T-01F |      |            |                       |                      |
| 30002-120T-F   | 120P |            |                       |                      |
| 30002-120T-01F |      |            |                       |                      |

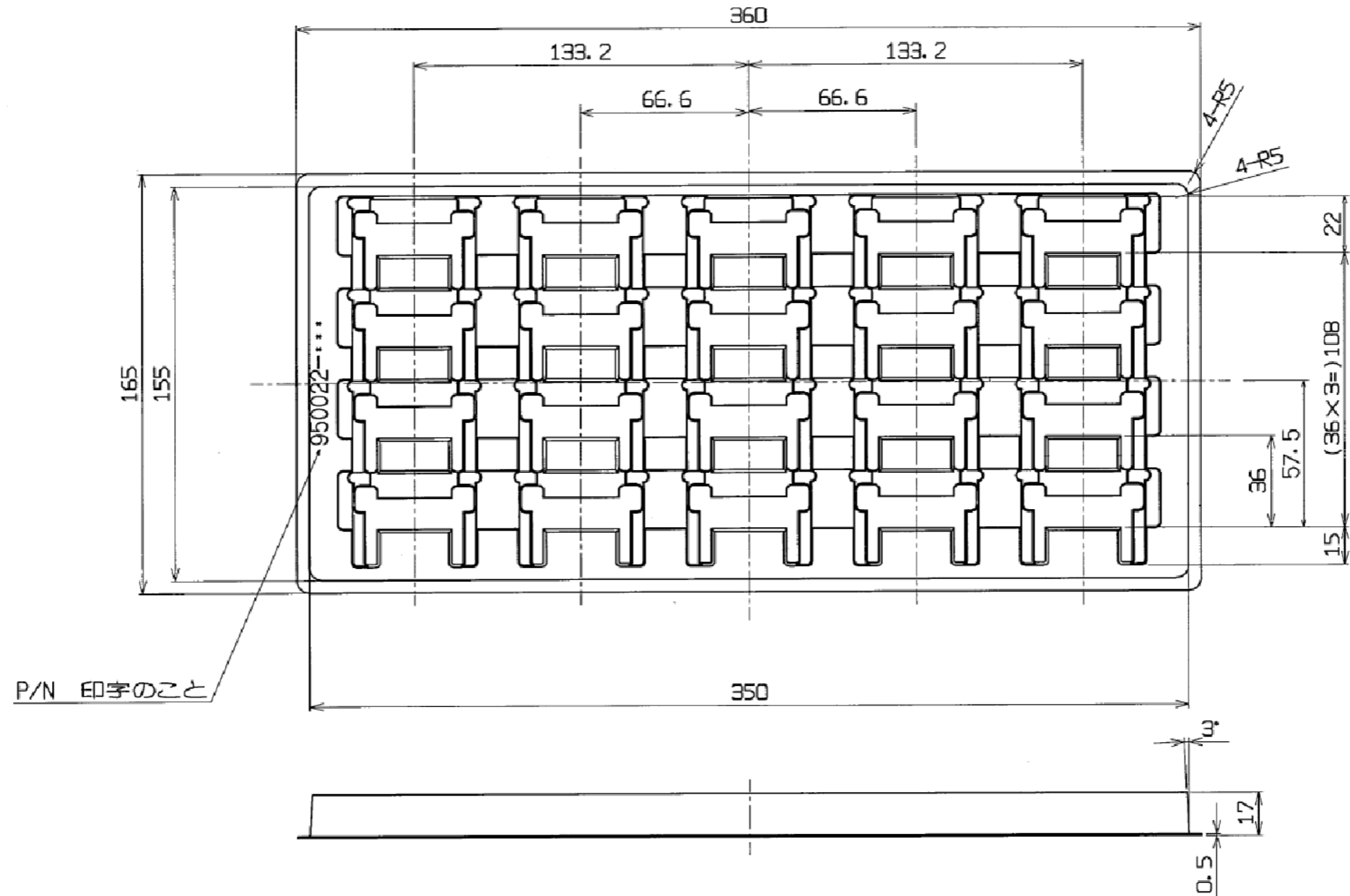

|                    |                       |  |                  |            |
|--------------------|-----------------------|--|------------------|------------|
| 8                  | TRAY                  | PVC  | -                |            |
| NO.                | DISCRIPTION           | MATERIAL   | FINISH , REMARKS |            |
| ANGLE              | ±2° 6 OVER 30 MAX.    | ±0.3   | PROJECTION       | SERIES No. |
| 6 MAX.             | ±0.2 30 OVER 120 MAX. | ±0.5   | ⊕                | R15        |
| GENERAL TOLERANCE. |                       | TITLE  |                  | SCALE      |
| DWG.               | DATE                  | MINIDOCK<br>CONNECTOR<br>RIGHT ANGLE<br>RECEPTACLE |                  | 1:X        |
| CHK.               |                       |  |                  | UNIT       |
| APP.               |                       | DWG. No. 30002                                     |                  | mm         |
|                    |                       |  |                  | SIZE       |
|                    |                       |  |                  | A3         |
|                    |                       |  |                  | SHEET      |
|                    |                       |  |                  | 5/5        |
|                    |                       |  |                  | REV.       |
|                    |                       |  |                  | 30         |