

**Recommended P/N 30047-160T-01F**

PART NO.	Pos.	NOTES	GUIDE PIN P/N
30047-160T-F	160P	WITH SCREW	TAPER TOP
30047-160T-01F		WITHOUT SCREW	
30047-160T-02F		WITH SCREW	SPHERE TOP
30047-160T-03F		WITHOUT SCREW	
30047-160T-04F		WITH SCREW	2'nd SPHERE TOP
30047-160T-05F	WITHOUT SCREW		

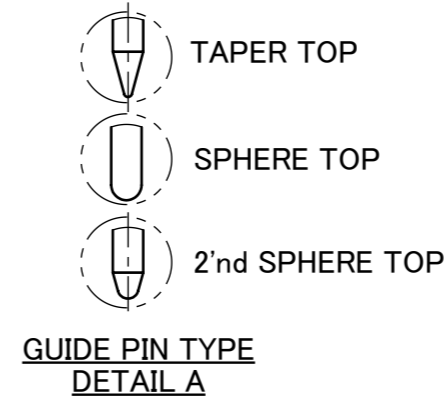

RoHS Compliant

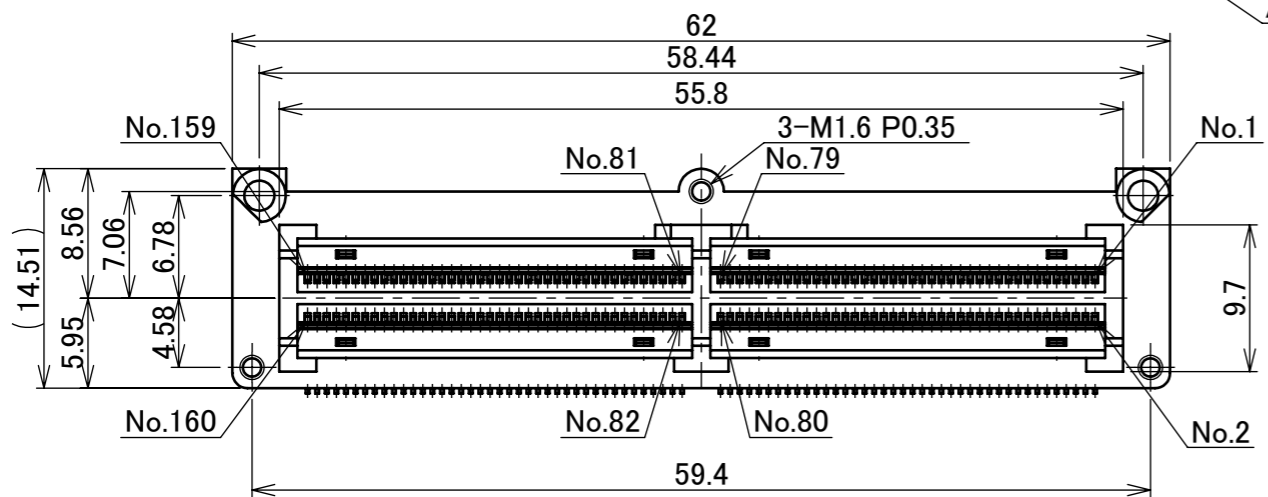
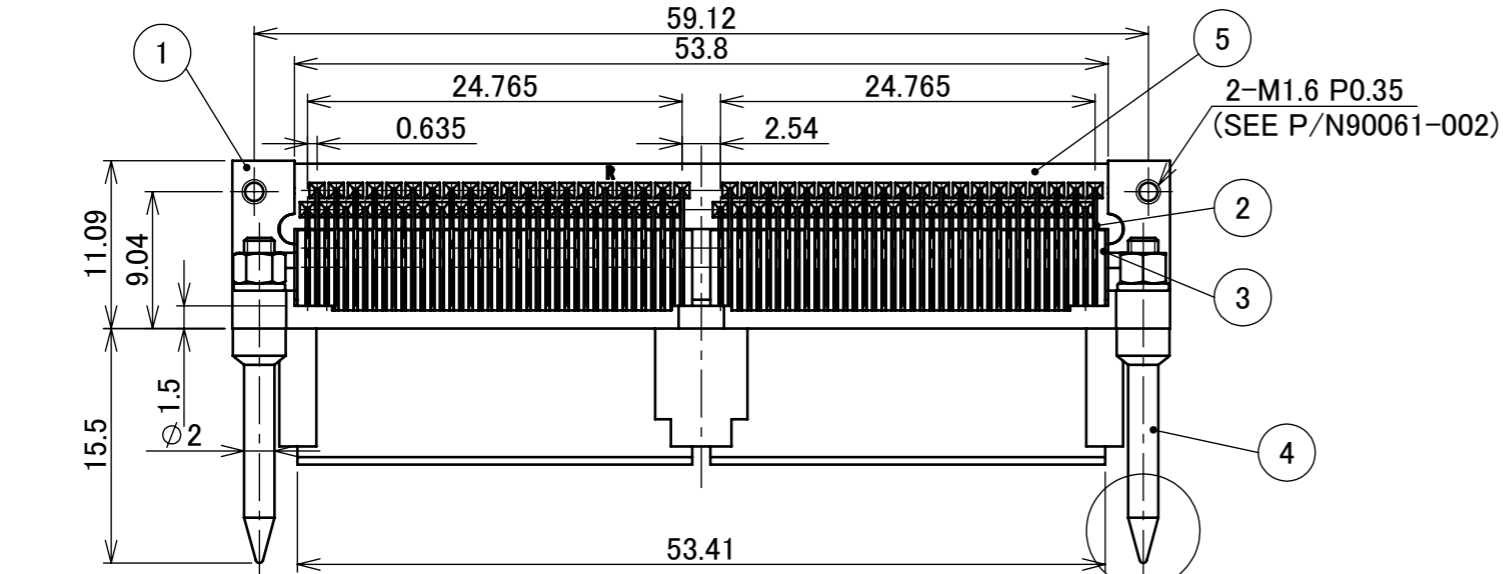

SCREW 90061-002  
SCALE 5/1

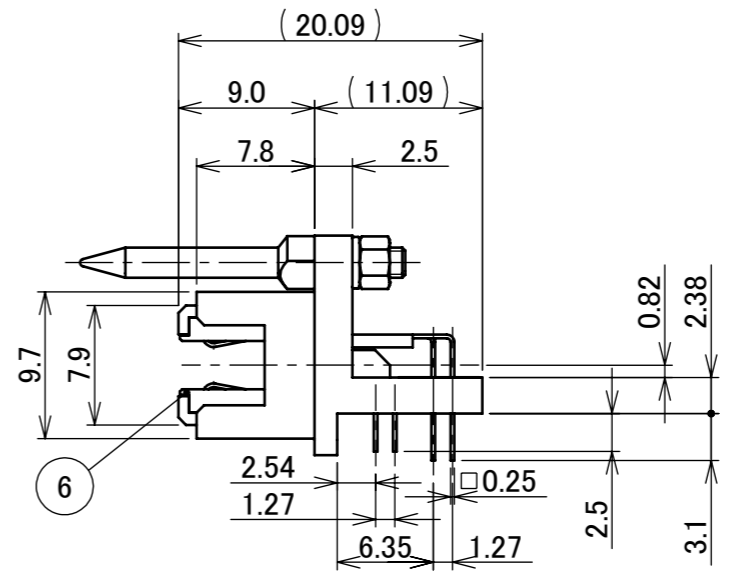
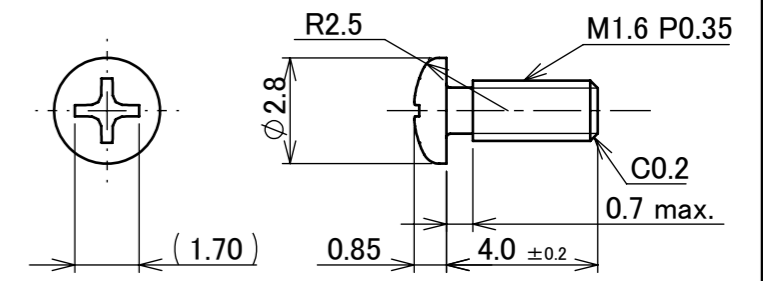

NO.	DESCRIPTION	MATERIAL	FINISH , REMARKS
6	CONTACT GUIDE	PPS	BLACK UL94V-0
5	LOCATOR PLATE	PA	BLACK UL94V-0
4	GUIDE PIN	STEEL	Ni PLATING
3	RECE INSULATOR	PPS	BLACK UL94V-0
2	RECE CONTACT	COPPER ALLOY	Au PLATING
1	RECE SHELL	Zn ALLOY	Ni PLATING

NOTES  
1. CONNECTOR TO BE MATED : 30046

REV.	ECN	BY	DATE	APP.	APP.	CHK.	DATE	PROJECTION	SERIES No.	TITLE	SCALE	SHEET	REV.
13	Z240897	K.W	July/09/'24	S.S	ANGLE	±2°	6 OVER 30 MAX.	±0.3		R2	MINIDOCK™ Slim Type RIGHT ANGLE RECEPTACLE	A3	13
12	Z240688	Y.I	Jun./06/'24	M.T	6 MAX.	±0.2	30 OVER 120 MAX.	±0.5					
11	Z220241	M.H	Mar./18/'22	Y.H	GENERAL TOLERANCE.								
10	Z191328	IMI	Oct./01/'19	Y.S	DWG.	T.Takano		DATE	1997/03/10				
9	Z180835	R.H	June/27/'18	TAK									
8	Z171490	R.H	Dec./25/'17	M.T	CHK.	T.Harada							
REVISION RECORD					APP.	K.Katabuchi		DWG. No.	30047			1/4	

ITEMS	SPECIFICATION
RATING VOLTAGE	250V AC (PER CONTACT PIN)
RATING AMPERAGE (FOR CONTACT)	0.5A AC/DC (PER CONTACT PIN)
OPERATING TEMPERATURE	208~358K(-65°C~+85°C)
OPERATING HUMIDITY	85% MAX.
CONTACT RESISTANCE (FOR CONTACT)	INITIAL : 70mohm MAX. / AFTER TEST : $\triangleleft$ 25mohm MAX.
INSULATION RESISTANCE	INITIAL : 10,000Mohm MIN. / AFTER TEST : 1,000Mohm MIN.
DIELECTRIC WITHSTANDING VOLTAGE	AC500V 1min
DURABILITY	5,000 CYCLES
MATING FORCE (INITIAL)	0.9N/pos. MAX.
UNMATING FORCE (AFTER TEST)	0.059N/pos. MIN.
COPLANARITY	-
PRODUCT SPECIFICATION	PRS-1011
TEST REPORT	TR-9020
PACKING STANDARD	300-107
INSTRUCTION MANUAL	-
APPEARANCE CRITERIA No.	QLS-A***

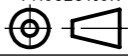
ANGLE	$\pm 2^\circ$	6 OVER 30 MAX.	$\pm 0.3$	PROJECTION 	SERIES No. R2	CUSTOMER COPY		
6 MAX.	$\pm 0.2$	30 OVER 120 MAX.	$\pm 0.5$					
GENERAL TOLERANCE.				TITLE MINIDOCK™ Slim Type RIGHT ANGLE RECEPTACLE	SCALE	<b>I-PEX</b>		
DWG.	DATE							
CHK.								
APP.								
				DWG. No.	30047	SIZE A3	SHEET 2/4	REV. 13

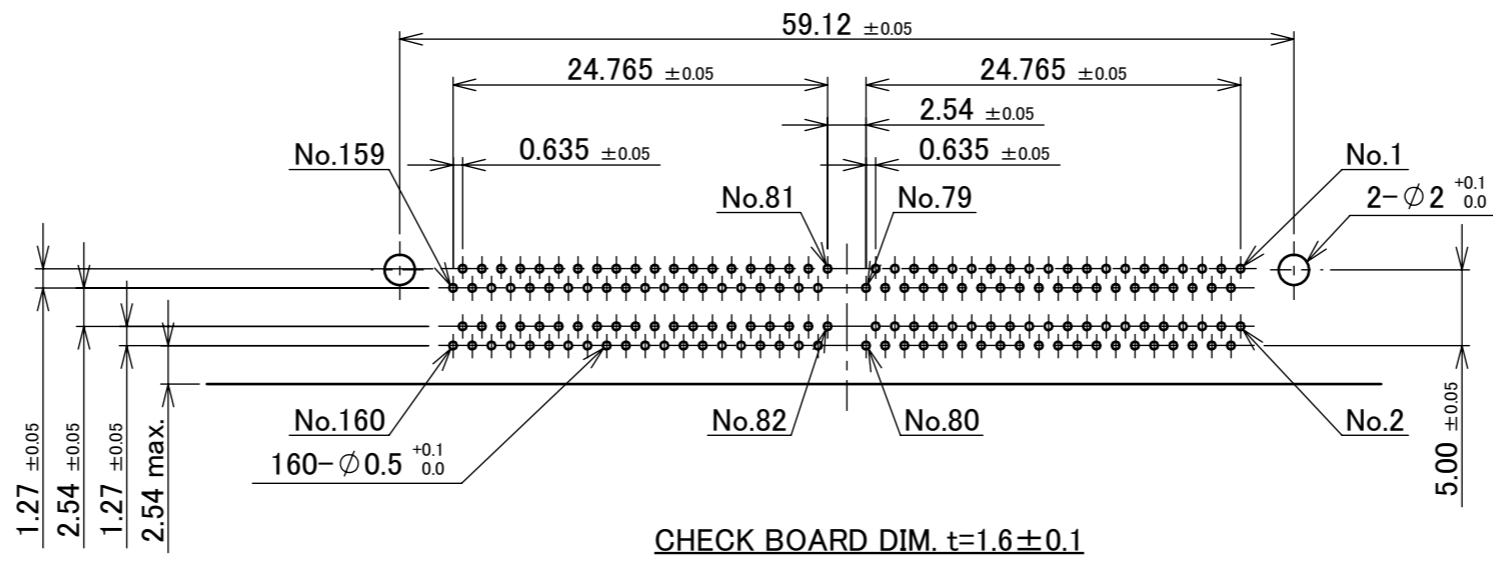

ANGLE	±2°	6 OVER 30 MAX.	±0.3	PROJECTION ⊕	SERIES No. R2	CUSTOMER COPY		
6 MAX.	±0.2	30 OVER 120 MAX.	±0.5					
GENERAL TOLERANCE.				TITLE MINIDOCK™ Slim Type RIGHT ANGLE RECEPTACLE	SCALE 5:1 UNIT mm	I-PEX		
DWG.	DATE							
CHK.								
APP.								
				DWG. No.	30047	SIZE A3	SHEET 3/4	REV. 13

PART NO.	Pos.	QTY./ TRAY	QTY./ SHIPPING CARTON	QTY./ PACKING CARTON
30047-160T-F	160P	16	16 × 3 = 48	48 × 4 = 192
30047-160T-0*F				

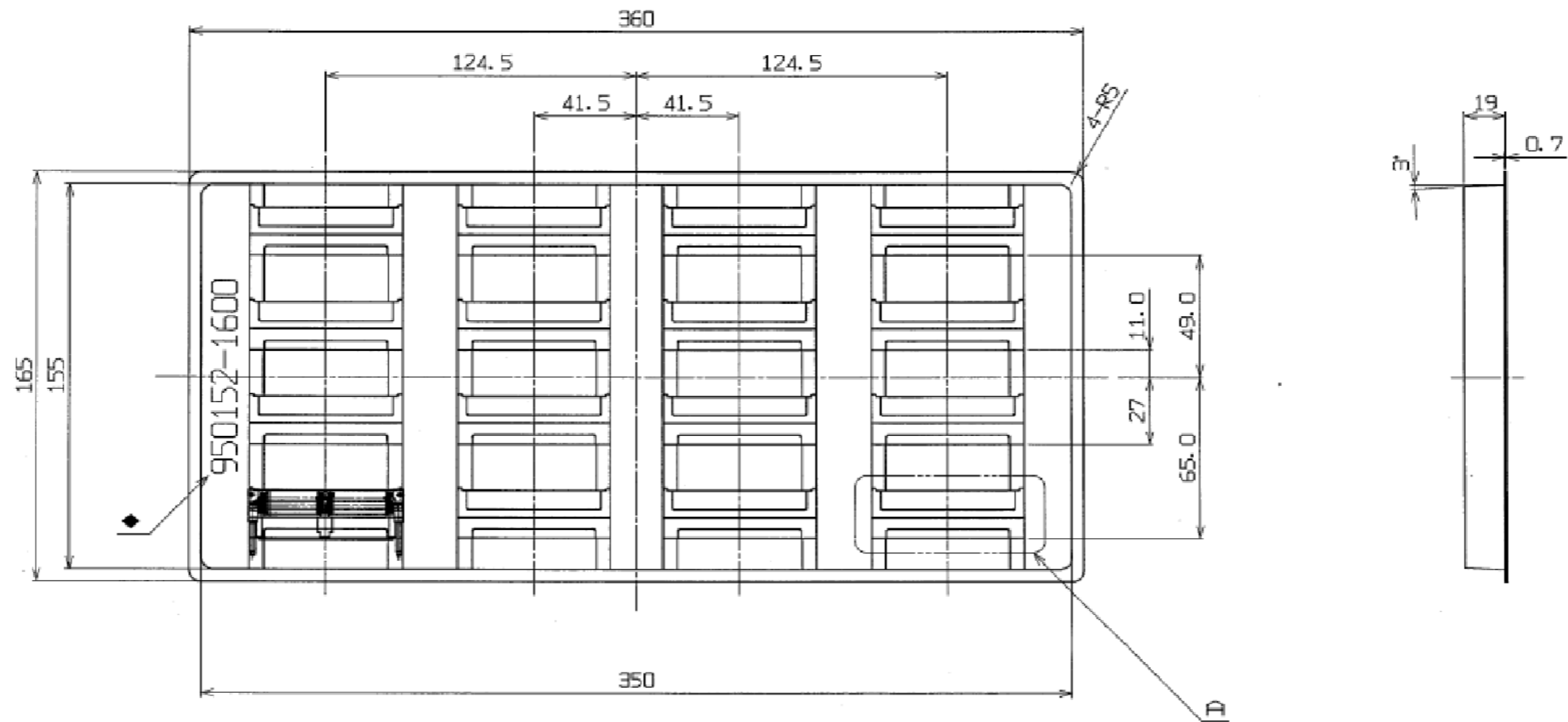

7	TRAY	PVC	-
NO.	DESCRIPTION	MATERIAL	FINISH , REMARKS

ANGLE	±2°	6 OVER 30 MAX.	±0.3	PROJECTION ⊕	SERIES No. R2	CUSTOMER COPY		
6 MAX.	±0.2	30 OVER 120 MAX.	±0.5					
GENERAL TOLERANCE.				TITLE MINIDOCK™ Slim Type RIGHT ANGLE RECEPTACLE	SCALE 1:X UNIT mm	I-PEX		
DWG.	DATE							
CHK.								
APP.								
				DWG. No.	30047	SIZE A3	SHEET 4/4	REV. 13