

PART NO.

91197-300P



Halogen Free



RoHS Compliant

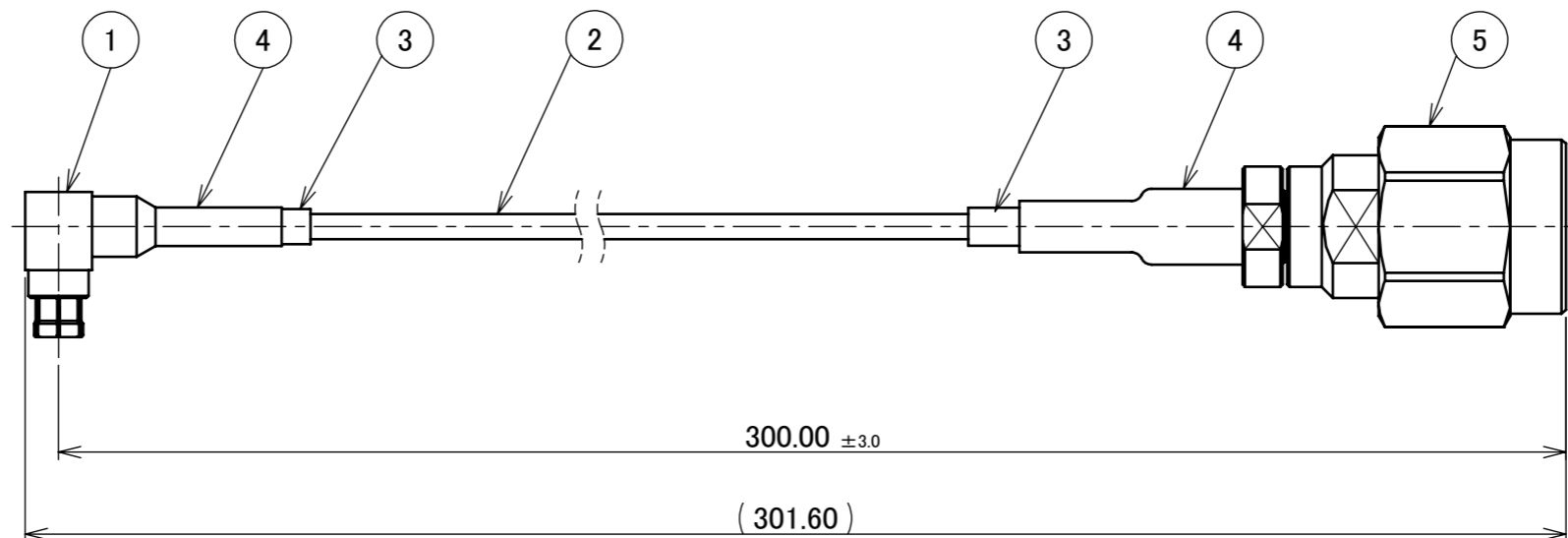
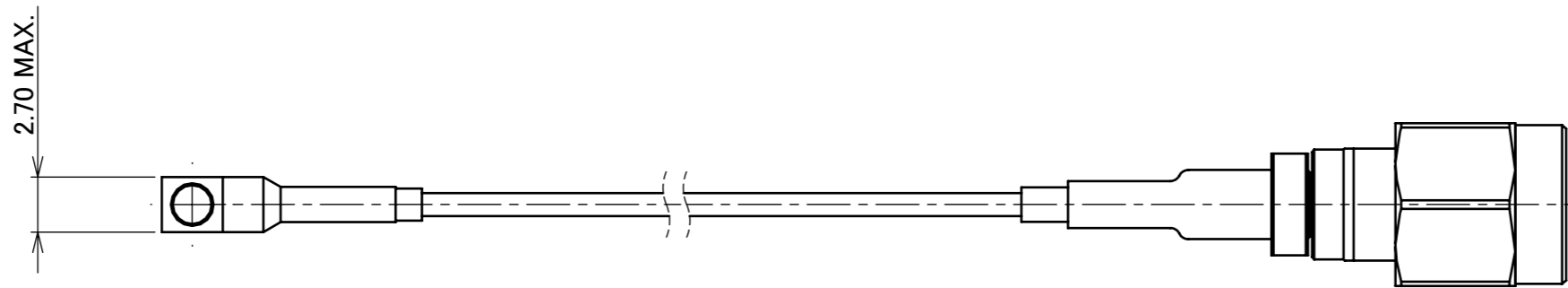

5	SMA PLUG	-	-
4	HEAT SHRINK TUBE	-	BLACK
3	HEAT SHRINK TUBE	-	BLACK
2	CABLE	-	BLACK
1	SMPM JACK	-	-
NO.	DESCRIPTION	MATERIAL	FINISH, REMARKS
		ANGLE $\pm 2^\circ$ 6 OVER 30 MAX. ± 0.3	PROJECTION SERIES No. R0
		6 MAX. ± 0.2 30 OVER 120 MAX. ± 0.5	CUSTOMER COPY
		GENERAL TOLERANCE.	
		DWG. K.Watanabe DATE 2022/11/30	TITLE MHF® SERIES N30 SMPM TO SMA ADAPTER CABLE
		CHK. K.Yufu	SCALE 3:1 UNIT mm
0	Z221339	K.W	2022/11/30
REV.	ECN	BY	DATE
		APP.	APP.
REVISION RECORD			
		Y.Hashimoto	DWG. No. 91197
			SIZE A3 SHEET 1/3 REV. 0

PART NO.

91197-300J



Halogen Free



RoHS Compliant

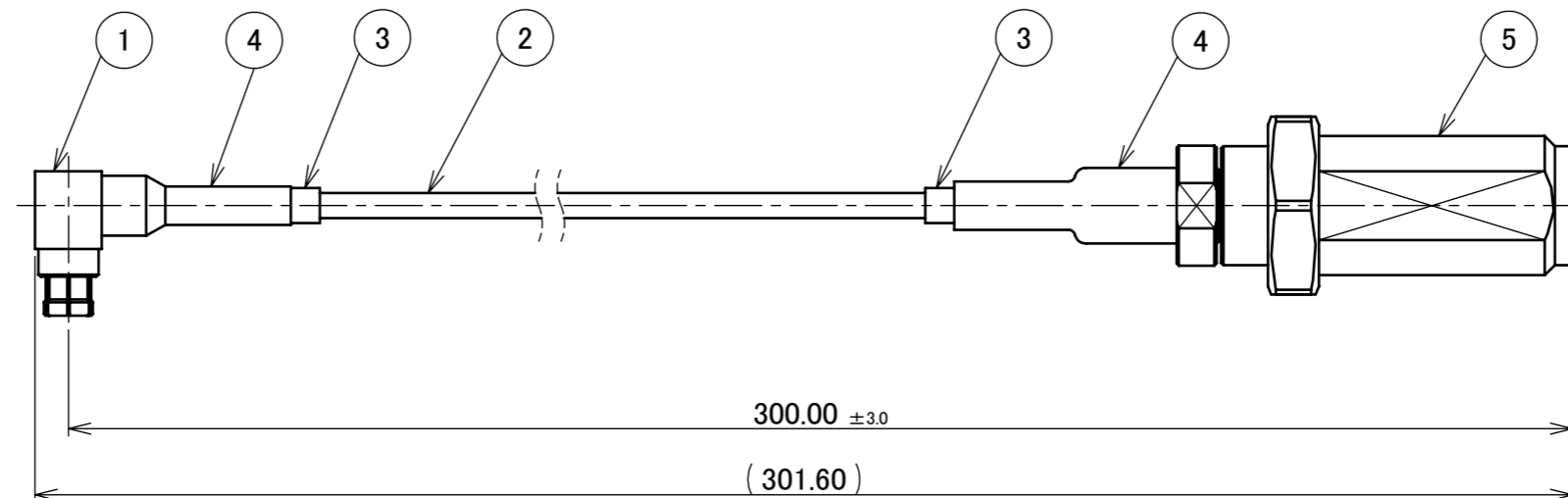
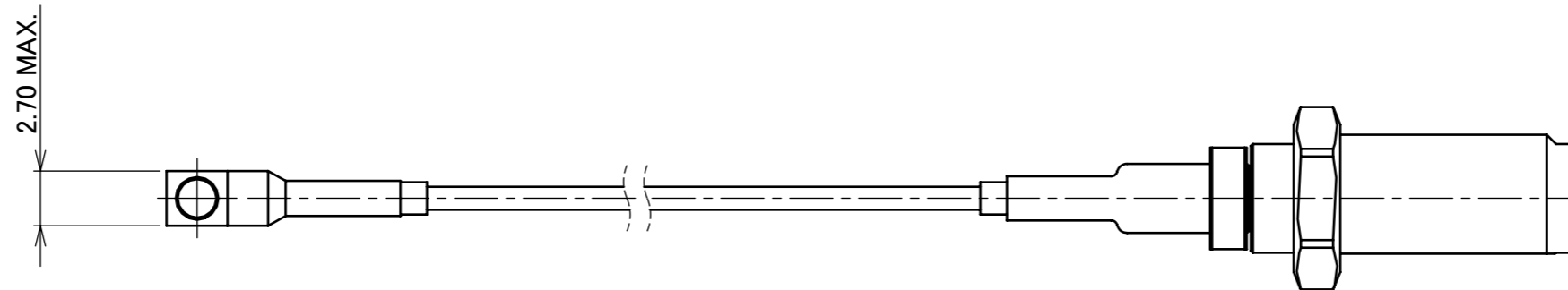

5	SMA JACK	-	-
4	HEAT SHRINK TUBE	-	BLACK
3	HEAT SHRINK TUBE	-	BLACK
2	CABLE	-	BLACK
1	SMPM JACK	-	-
NO.	DESCRIPTION	MATERIAL	FINISH, REMARKS
		ANGLE $\pm 2^\circ$ 6 OVER 30 MAX. ± 0.3	PROJECTION SERIES No. R0
		6 MAX. ± 0.2 30 OVER 120 MAX. ± 0.5	CUSTOMER COPY
		GENERAL TOLERANCE.	TITLE MHF® SERIES N30 SMPM TO SMA ADAPTER CABLE
		DWG. DATE	SCALE 3:1
		CHK.	UNIT mm
REV.	ECN	BY	DATE
			APP.
REVISION RECORD			
		APP.	DWG. No. 91197
			SIZE A3 SHEET 2/3 REV. 0

ITEMS	SPECIFICATION	
APPLICATION (REPRESENTATIVE)	MHF 7 (S) RECEPTACLE HIGH CYCLE N30 SMPM ADAPTER P/N: 91136-0001	MHF 7 (S) RECEPTACLE HIGH CYCLE F N30 SMPM ADAPTER P/N: 91145-0001
OPERATING TEMPERATURE	243~343 K (-30°C~+70°C)	
SPEC	SEE DWG No. 91136 AND DWG No. 91145	
DURABILITY	100 CYCLES MAX. (SMPM JACK)	
PRODUCT SPECIFICATION	PRS-2803	PRS-2802
TEST REPORT	TR-22036	TR-22026
INSTRUCTION MANUAL	HIM-22018	HIM-22015
PACKING STANDARD	PST-12054	
APPEARANCE CRITERIA No.	QLS-A***	QLS-A***

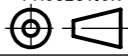
ANGLE	±2°	6 OVER 30 MAX.	±0.3	PROJECTION 	SERIES No. R0	CUSTOMER COPY		
6 MAX.	±0.2	30 OVER 120 MAX.	±0.5					
GENERAL TOLERANCE.				TITLE MHF® SERIES N30 SMPM TO SMA ADAPTER CABLE	SCALE	I-PEX		
DWG.	DATE				-			
CHK.					UNIT			
APP.					mm			
				DWG. No.	91197	SIZE	SHEET	REV.
					A3	3/3	0	