

Recommended P/N 20279-001E-03

PART NO.	PACKING REEL	QUANTITY IN 1 REEL
20279-001E-01	PLASTIC REEL	2,500
	CORRUGATED PAPER REEL	2,500
20279-001E-03	PLASTIC REEL	5,000
20279-001E-05	PLASTIC REEL	10,000



Halogen Free



RoHS Compliant

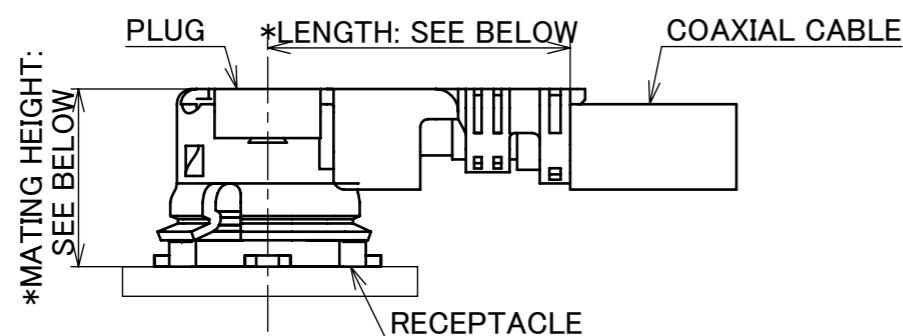
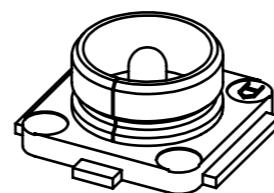
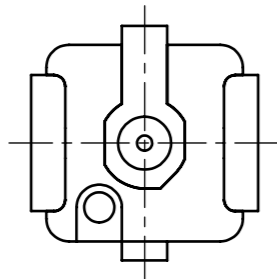
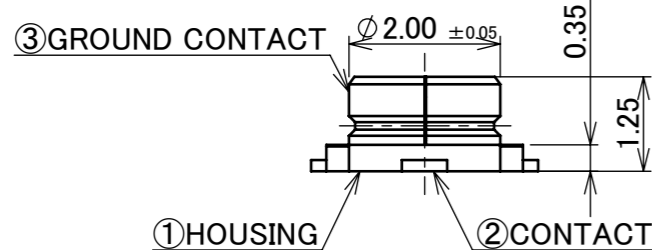
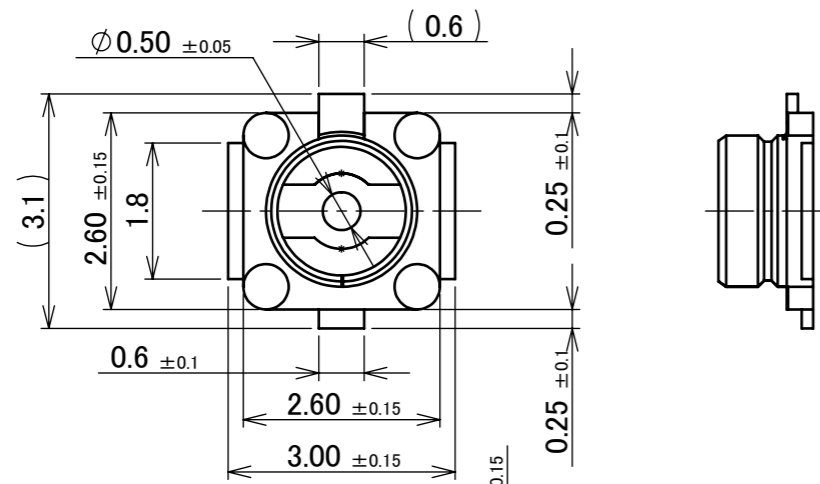

\*LENGTH: 4.0±0.4 AT PLUG PART NO. 20670-001R-08, 20670-001R-13, 20670-001R-32  
 4.7±0.4 AT PLUG PART NO. 20670-001R-18, 20670-001R-37  
 5.6 AT PLUG PART NO. 20767-001R-20 (REFERENCE DIMENSION)  
 3.8±0.3 AT PLUG PART NO. 20686-001R-08, 20311-011R-\*\*  
 \*MATING HEIGHT: 2.5 MAX. AT PLUG PART NO. 20670-001R-\*\*  
 (2.9 MAX. AT MHF I LK LOCKED CONDITION)  
 3.0 MAX. AT PLUG PART NO. 20767-001R-20  
 2.0±0.1 AT PLUG PART NO. 20686-001R-08, 20311-011R-\*\*

**MATING CONDITION**

**NOTES**

- APPLICABLE CONNECTOR PART NO.  
 MHF I PLUG  
 20278-11\*R-\*\*  
 20351-\*\*\*R-37  
 20631-\*\*\*R-\*\*  
 20670-001R-\*\*  
 20767-001R-20  
 MHF II PLUG  
 20311-011R-\*\*  
 20686-001R-08
- COPLANARITY: 0.1mm MAX.
- THIS IS "Pb-FREE" CONNECTOR.

NO.	DISCRIPTION	MATERIAL	FINISH , REMARKS
3	GROUND CONTACT	PHOSPHOR BRONZE	ALL OVER Ni 1.00 μm MIN. CONTACT PART Au 0.05 μm MIN. SOLDERING PART Au 0.05 μm MIN.
2	CONTACT	BRASS	ALL OVER Ni 1.00 μm MIN. CONTACT PART Au 0.10 μm MIN. SOLDERING PART Au 0.03 μm MIN.
1	HOUSING	LCP	UL94V-0, WHITE

REV.	ECN	BY	DATE	APP.	APP.	DWG. No.	SHEET	REV.
31	Z230930	K.M	2023/08/08	Y.H	ANGLE ±2°	6 OVER 30 MAX.	±0.3	
30	Z230799	Y.I	2023/07/12	M.T	6 MAX. ±0.2	30 OVER 120 MAX.	±0.5	
29	Z230201	TOI	2023/02/20	Y.H	GENERAL TOLERANCE.			
28	Z220594	TSU	2022/05/27	Y.H	DWG. K.Oobayashi	DATE 2001/06/07		
27	Z210232	S.T	2021/03/08	M.T	CHK.			
26	Z200434	TOI	2020/04/20	Y.H	E.Kawabe			
REVISION RECORD					K.Katabuchi	20279	A3	1/9

TITLE	SERIES No.	SCALE	CUSTOMER COPY
MHF® I/II RECEPTACLE	R9	10:1	
		UNIT	<b>I-PEX</b>
		mm	
		SIZE	
		SHEET	
			31

Recommended P/N 20279-001E-03

PART NO.	PACKING REEL	QUANTITY IN 1 REEL
20279-001E-06	PLASTIC REEL	10,000



Halogen Free



RoHS Compliant

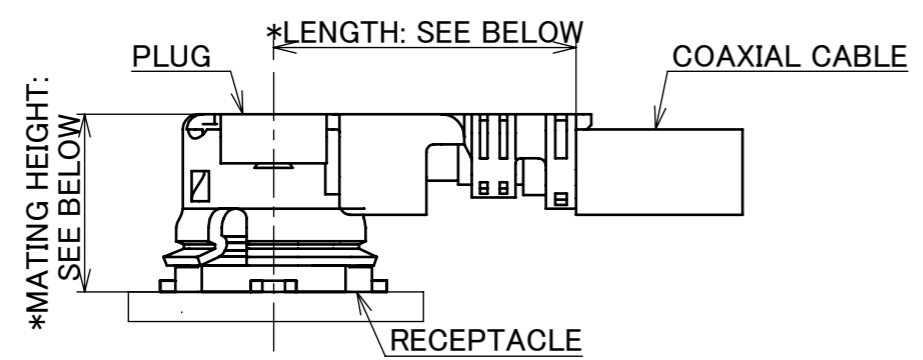
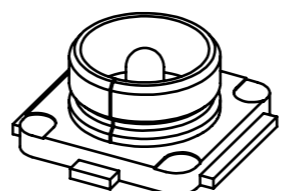
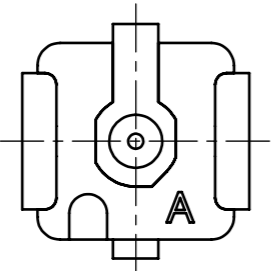
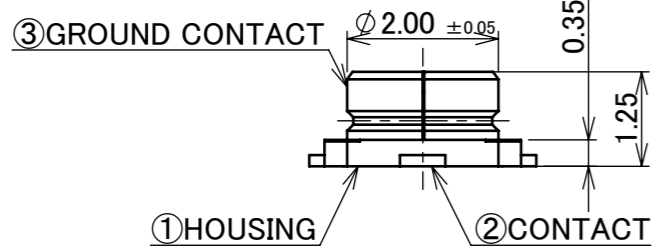
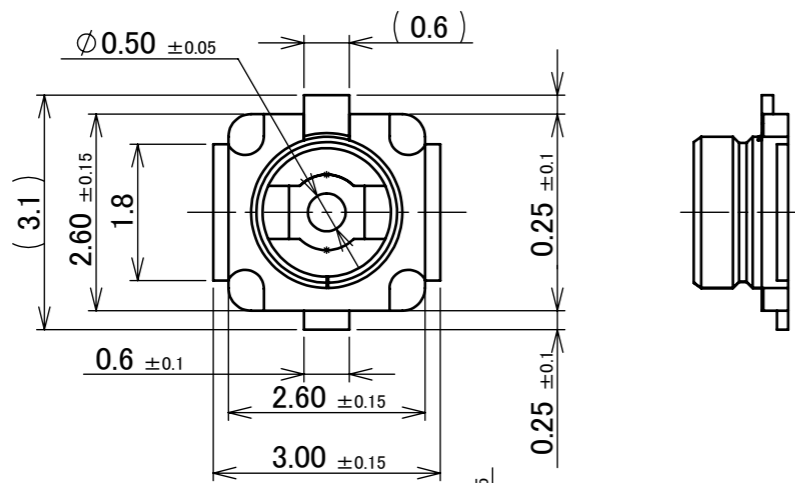

\*LENGTH: 4.0±0.4 AT PLUG PART NO. 20670-001R-08, 20670-001R-13, 20670-001R-32  
 4.7±0.4 AT PLUG PART NO. 20670-001R-18, 20670-001R-37  
 5.6 AT PLUG PART NO. 20767-001R-20 (REFERENCE DIMENSION)  
 3.8±0.3 AT PLUG PART NO. 20686-001R-08, 20311-011R-\*\*

\*MATING HEIGHT: 2.5 MAX. AT PLUG PART NO. 20670-001R-\*\*  
 (2.9 MAX. AT MHF I LK LOCKED CONDITION)  
 3.0 MAX. AT PLUG PART NO. 20767-001R-20  
 2.0±0.1 AT PLUG PART NO. 20686-001R-08, 20311-011R-\*\*

**MATING CONDITION**

**NOTES**

- APPLICABLE CONNECTOR PART NO.  
 MHF I PLUG  
 20278-11\*R-\*\*  
 20351-\*\*\*R-37  
 20631-\*\*\*R-\*\*  
 20670-001R-\*\*  
 20767-001R-20  
 MHF II PLUG  
 20311-011R-\*\*  
 20686-001R-08
- COPLANARITY: 0.1mm MAX.
- THIS IS "Pb-FREE" CONNECTOR.

NO.	DISCRIPTION	MATERIAL	FINISH , REMARKS
3	GROUND CONTACT	PHOSPHOR BRONZE	ALL OVER Ni 1.00 μ m MIN. CONTACT PART Au 0.05 μ m MIN. SOLDERING PART Au 0.05 μ m MIN.
2	CONTACT	BRASS	ALL OVER Ni 1.00 μ m MIN. CONTACT PART Au 0.10 μ m MIN. SOLDERING PART Au 0.03 μ m MIN.
1	HOUSING	LCP	UL94V-0, WHITE

ANGLE	±2°	6 OVER 30 MAX.	±0.3	PROJECTION ⊕	SERIES No. R9	CUSTOMER COPY			
6 MAX.	±0.2	30 OVER 120 MAX.	±0.5						
GENERAL TOLERANCE.				TITLE		SCALE	<b>I-PEX</b>		
DWG.	DATE			MHF® I/II RECEPTACLE		10:1			
CHK.						UNIT			
APP.				DWG. No. 20279		mm			
						SIZE	SHEET	REV.	
						A3	2/9	31	

ITEMS	SPECIFICATION		
RECOMMENDED APPLICABLE CONNECTOR PART NO.	20670-001R-** (MHF I PLUG Ni TOP 1.80, 1.37, 1.32, 1.13, 0.81)	20767-001R-20 (MHF I PLUG 2.00)	20686-001R-08 (MHF II PLUG Ni TOP 0.81)
RATING VOLTAGE	60 V AC (R.M.S)		
RATING FREQUENCY	DC~9GHz		
OPERATING TEMPERATURE	233~363K (-40°C~+90°C)		
VSWR (MATED WITH SMA ADAPTER PART No.90193-002)	RECEPTACLE: 1.30 MAX. AT 0.1~3 GHz, 1.40 MAX. AT 3~6 GHz, 1.80 MAX. AT 6~9 GHz		
MAIN CONTACT RESISTANCE	INITIAL: 20 mohm MAX. / AFTER TEST: $\Delta$ R 20 mohm MAX.		
GROUND CONTACT RESISTANCE	INITIAL: 20 mohm MAX. / AFTER TEST: $\Delta$ R 100 mohm MAX.		
INSULATION RESISTANCE	INITIAL: 500 Mohm MIN. / AFTER TEST: 100 Mohm MIN.		
DIELECTRIC WITHSTANDING VOLTAGE	200 V AC, 1 MINUTE		
DURABILITY	30 CYCLES		
UNMATING FORCE (INITIAL / AFTER TEST)	INITIAL: 5 N MIN. AFTER TEST: 3 N MIN.		INITIAL: 4 N MIN. AFTER TEST: 2 N MIN.
PRODUCT SPECIFICATION	PRS-2105	PRS-2490	PRS-2106
TEST REPORT	TR-15059	TR-18041	TR-15060
PACKING STANDARD	20279-001E-01: 300-232 (CORRUGATED PAPER REEL) PST-12002 (ANTI-STATIC PLASTIC REEL) 20279-001E-03: 300-850 20279-001E-05: PST-13040 20279-001E-06: PST-13040		
INSTRUCTION MANUAL	HIM-10002		HIM-12010
APPEARANCE CRITERIA No.	QLS-A***		

※UNLESS OTHERWISE SPECIFIED, 20279-001E-01 WILL BE DELIVERED IN CORRUGATED PAPER REELS.  
CONTACT YOUR I-PEX SALES IF YOU WISH FOR PLASTIC REELS.

ANGLE	$\pm 2^\circ$	6 OVER 30 MAX.	$\pm 0.3$	PROJECTION 	SERIES No. R9	CUSTOMER COPY		
6 MAX.	$\pm 0.2$	30 OVER 120 MAX.	$\pm 0.5$			SCALE -	<b>I-PEX</b>	
GENERAL TOLERANCE.				TITLE MHF® I/II RECEPTACLE	UNIT mm			
DWG.	DATE			DWG. No. 20279	SIZE A3	SHEET 3/9		REV. 31
CHK.								
APP.								

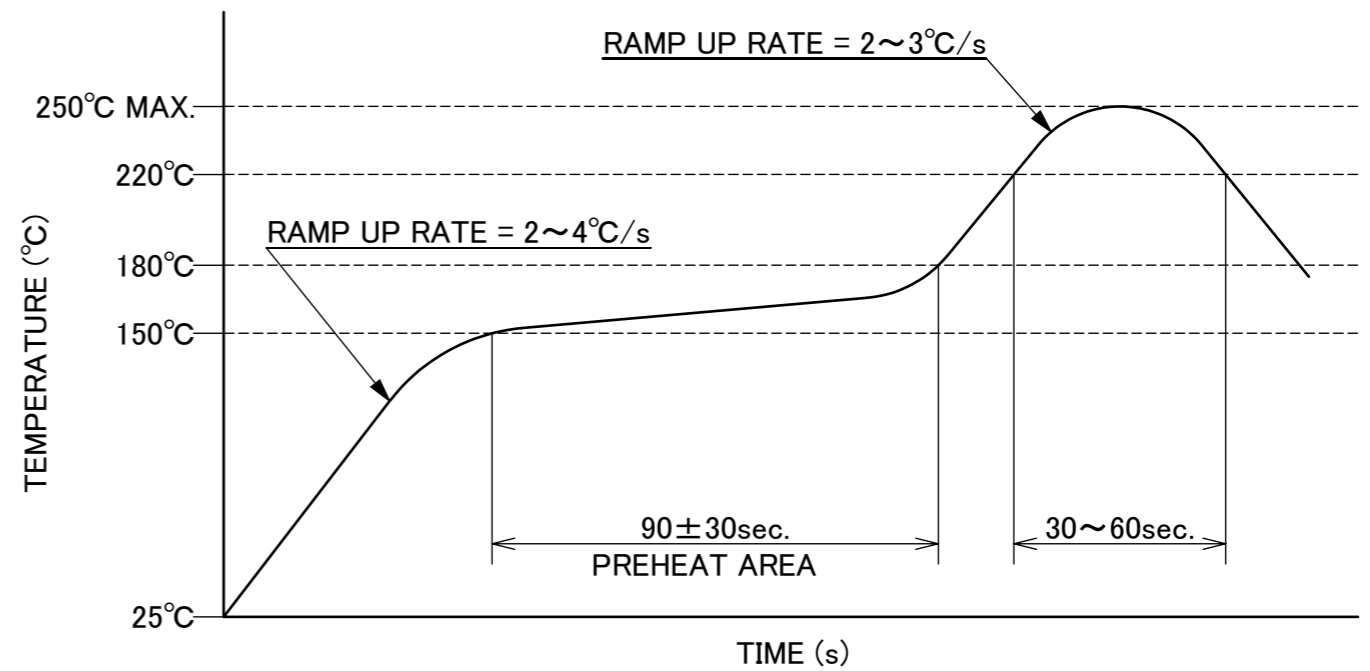
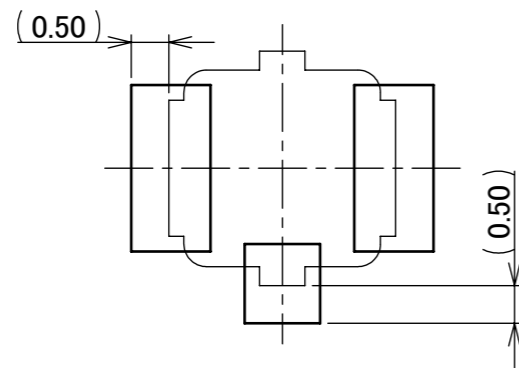
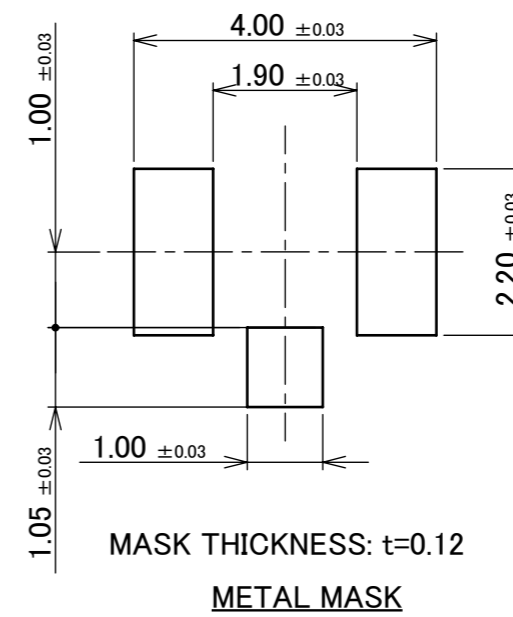
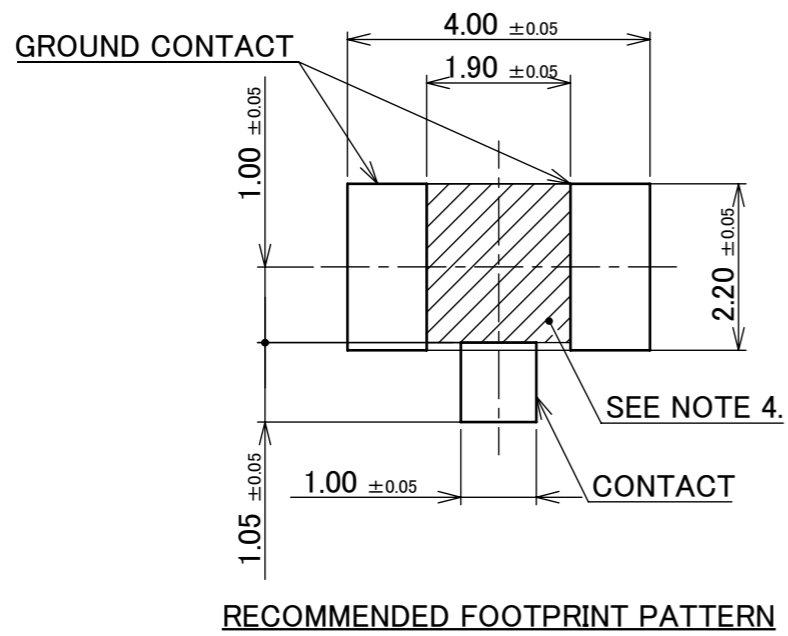

SENJU METAL INDUSTRY CO., LTD. : M705-SHF(Sn96.5 Ag3.0 Cu0.5)

NOTES.  
4. NO GROUND, SIGNAL, AND RESIST IN THIS AREA.

ANGLE	±2°	6 OVER 30 MAX.	±0.3	PROJECTION ⊕	SERIES No. R9	CUSTOMER COPY			
6 MAX.	±0.2	30 OVER 120 MAX.	±0.5						
GENERAL TOLERANCE.				TITLE		SCALE	<b>I-PEX</b>		
DWG.	DATE			MHF® I/II RECEPTACLE		10:1			
CHK.						UNIT			
APP.				DWG. No.		mm			
				20279		SIZE	SHEET	REV.	
						A3	4/9	31	

# COMPONENT PLACEMENT PROHIBITED AREA FOR MHF I/II RECEPTACLE MATED WITH MHF I LK HARNESS REQUIRED AREA FOR RECOMMENDED JIG TO OPERATE

## SINGLE CONNECTOR LAYOUT

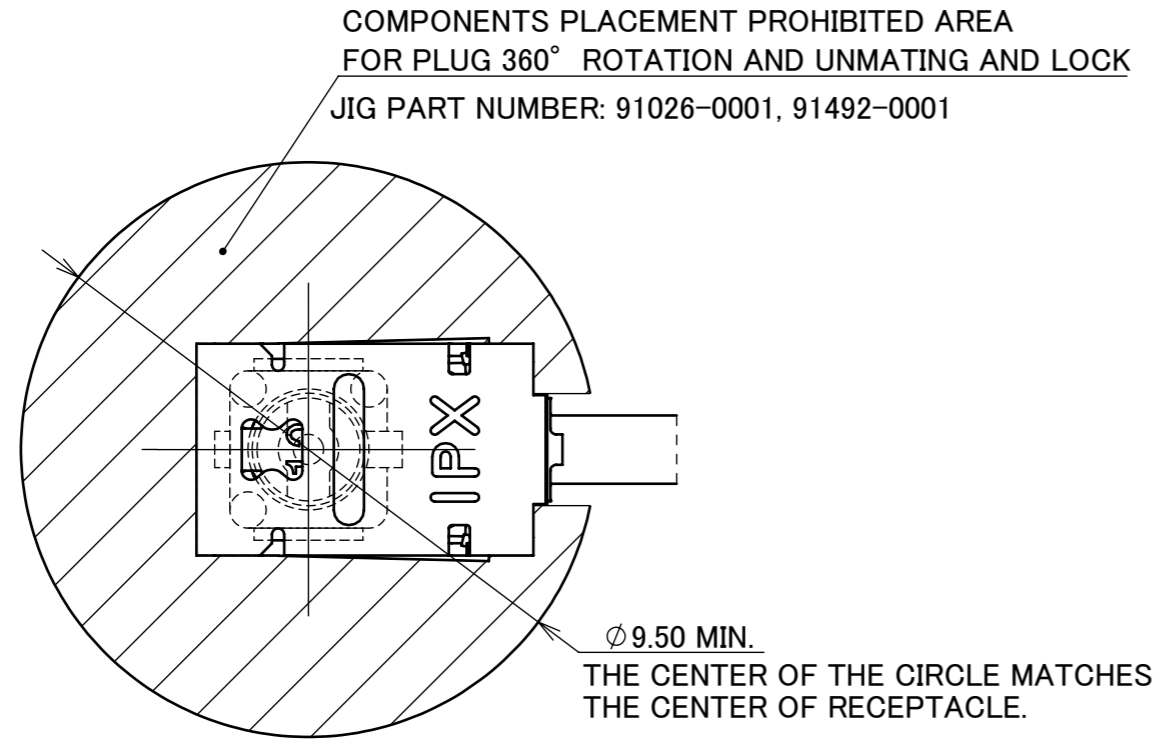

MATING AND LOCK CONDITION  
WITH MHF I LK HARNESS

## MULTIPLE CONNECTORS LAYOUT

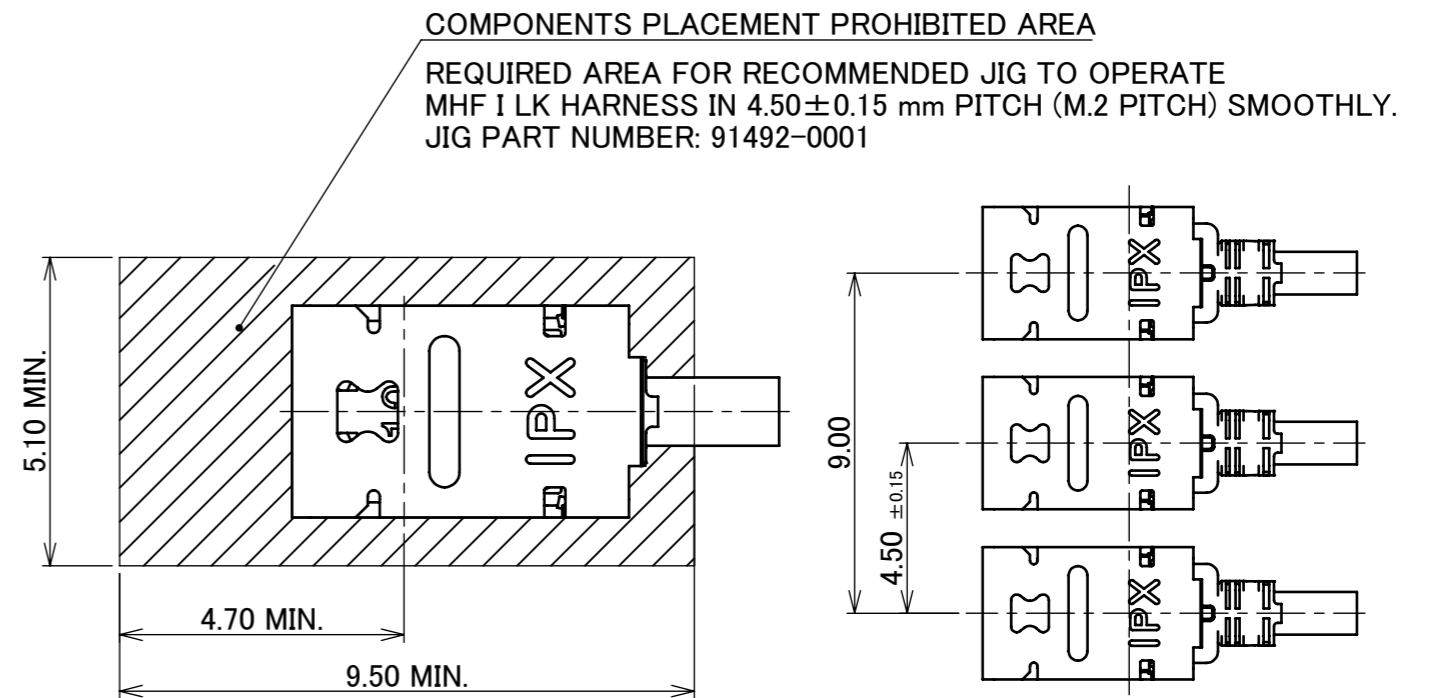

MATING AND LOCK CONDITION  
WITH MHF I LK HARNESS NARROW PITCH

MHF I LK HARNESS UNLOCK CONDITION  
NARROW PITCH DIMENSIONS  
(S = 5 : 1)

ANGLE	±2°	6 OVER 30 MAX.	±0.3	PROJECTION ⊕	SERIES No. R9	CUSTOMER COPY			
6 MAX.	±0.2	30 OVER 120 MAX.	±0.5						
GENERAL TOLERANCE.				TITLE MHF® I/II RECEPTACLE	DWG. No. 20279	SCALE	<b>I-PEX</b>		
DWG.	DATE					8:1			
CHK.						UNIT			
APP.						mm			
						SIZE	SHEET	REV.	
						A3	5/9	31	

PART NO.	A	QTY. PER EMBOSS REEL (PIECES / REEL)	QTY. PER PACKING CARTON (REELS / CARTON)
20279-001E-01	12.4	2,500 / REEL	8 REELS / CARTON = 20,000 PIECES

※UNLESS OTHERWISE SPECIFIED, 20279-001E-01 WILL BE DELIVERED IN CORRUGATED PAPER REELS.  
CONTACT YOUR I-PEX SALES IF YOU WISH FOR PLASTIC REELS.

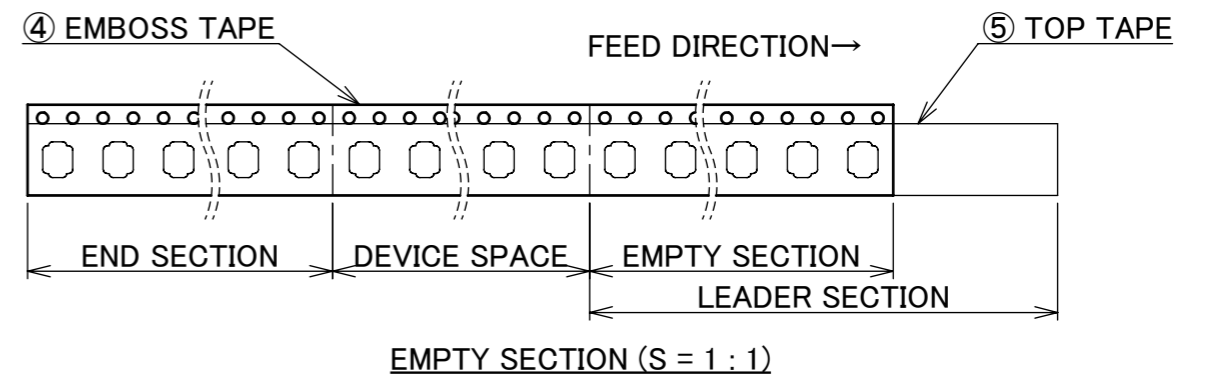
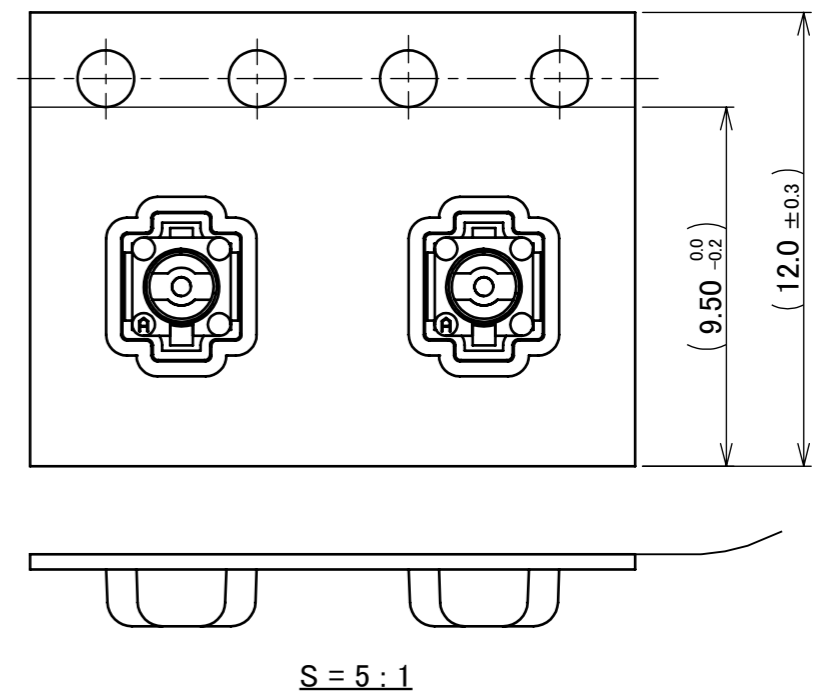
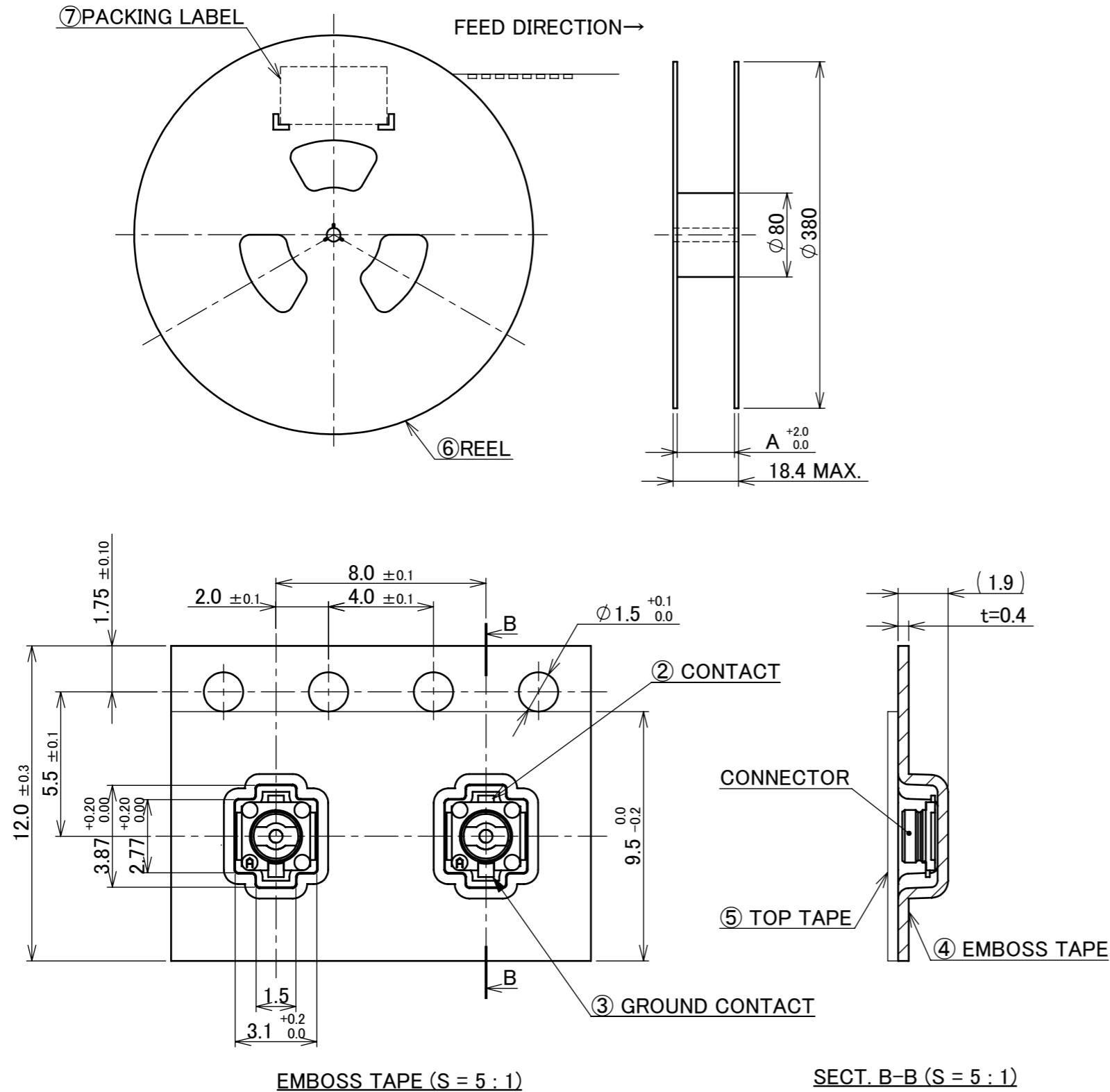

NOTES.

5. TAPING SPECIFICATION FOLLOWS JIS C 0806 (IEC 60286-3).
6. MAKE EMPTY SECTION OF LEADER AND END ON EACH END OF THE TAPE.
7. TOP TAPE SHALL NOT STICK OUT FROM EMBOSS TAPING.
8. TOP TAPE SHALL NOT COVER FEED HOLE.

NO.	DISCRIPTION	MATERIAL	FINISH , REMARKS
7	PACKING LABEL	-	-
6	REEL	CORRUGATED PAPER	-
5	TOP TAPE	PET t=0.075	-
4	EMBOSS TAPE	PP t=0.4	-

ANGLE	±2°	6 OVER 30 MAX.	±0.3	PROJECTION	SERIES No.	CUSTOMER COPY		
6 MAX.	±0.2	30 OVER 120 MAX.	±0.5		R9	SCALE	I-PEX	
GENERAL TOLERANCE.				TITLE	DWG. No.	1:X	SIZE	SHEET
DWG.	DATE			MHF® I/II RECEPTACLE		mm		
CHK.					20279	A3	6/9	31
APP.								

PART NO.	C	QTY. PER EMBOSS REEL (PIECES / REEL)	QTY. PER PACKING CARTON (REELS / CARTON)
20279-001E-01	12.0	2,500 / REEL	8 REELS / CARTON = 20,000 PIECES
20279-001E-03		5,000 / REEL	8 REELS / CARTON = 40,000 PIECES

※UNLESS OTHERWISE SPECIFIED, 20279-001E-01 WILL BE DELIVERED IN CORRUGATED PAPER REELS.  
CONTACT YOUR I-PEX SALES IF YOU WISH FOR PLASTIC REELS.

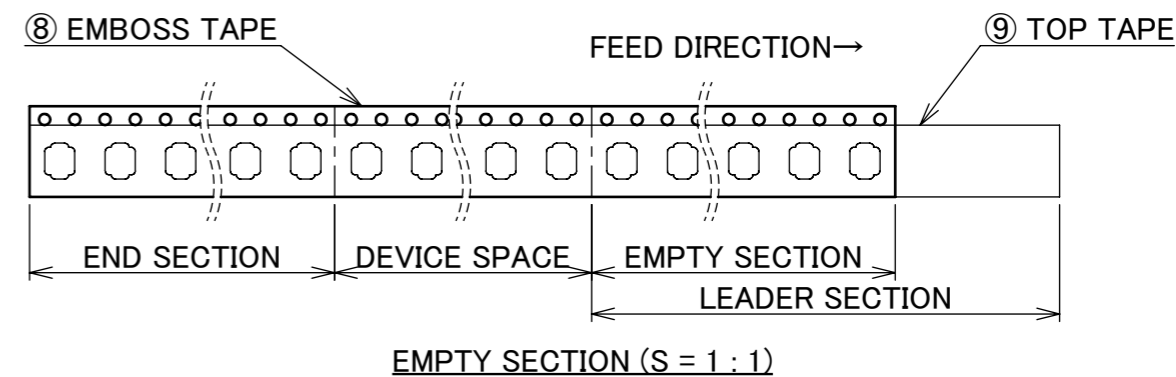
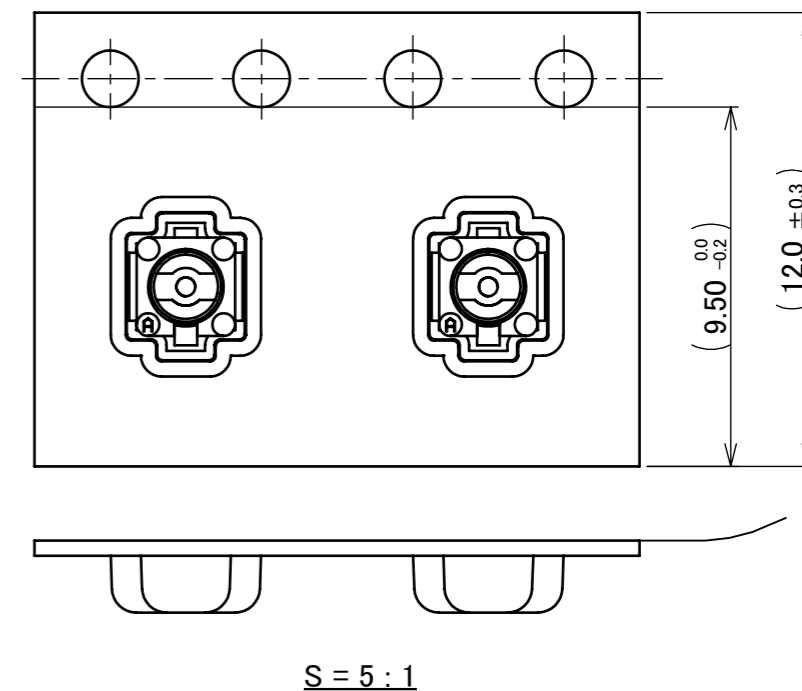
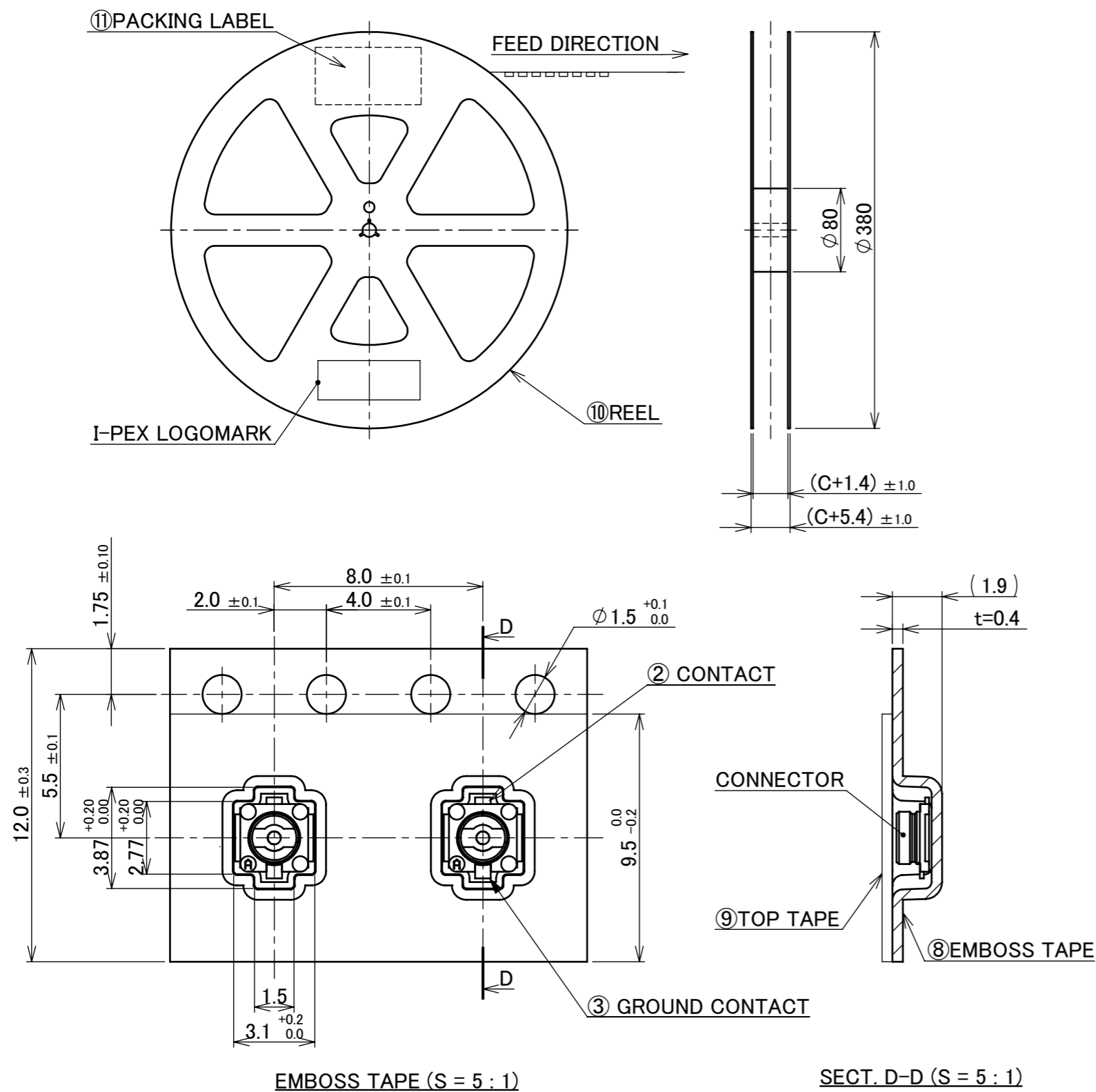

- NOTES.  
9. TAPING SPECIFICATION FOLLOWS JIS C 0806 (IEC 60286-3).  
10. MAKE EMPTY SECTION OF LEADER AND END ON EACH END OF THE TAPE.  
11. TOP TAPE SHALL NOT STICK OUT FROM EMBOSSED TAPING.  
12. TOP TAPE SHALL NOT COVER FEED HOLE.

NO.	DISCRIPTION	MATERIAL	FINISH , REMARKS
11	PACKING LABEL	-	-
10	REEL	PS ESD SAFE TYPE	-
9	TOP TAPE	PET t=0.075	-
8	EMBOSS TAPE	PP t=0.4	-

ANGLE	±2°	6 OVER 30 MAX.	±0.3	PROJECTION	SERIES No.	CUSTOMER COPY				
6 MAX.	±0.2	30 OVER 120 MAX.	±0.5		R9	SCALE	<b>I-PEX</b>			
GENERAL TOLERANCE.						TITLE				1:X
DWG.	DATE					MHF® I/II RECEPTACLE				UNIT
CHK.										mm
APP.						DWG. No.	SIZE	SHEET	REV.	
						20279	A3	7/9	31	

PART NO.	E	QUANTITY PER EMBOSS REEL (PIECES / REEL)	QUANTITY PER PACKING CARTON (REELS / CARTON)
20279-001E-05	12.0	10,000 / REEL	8 REELS / CARTON = 80,000 PIECES
20279-001E-06	12.0	10,000 / REEL	8 REELS / CARTON = 80,000 PIECES

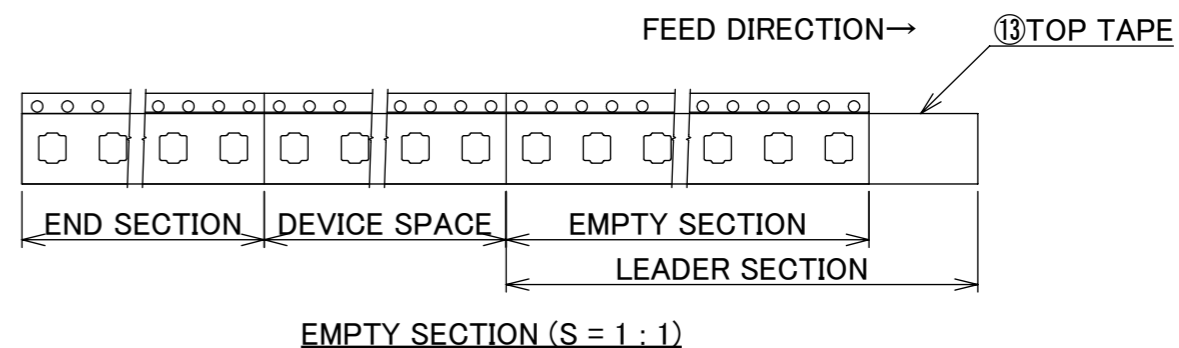
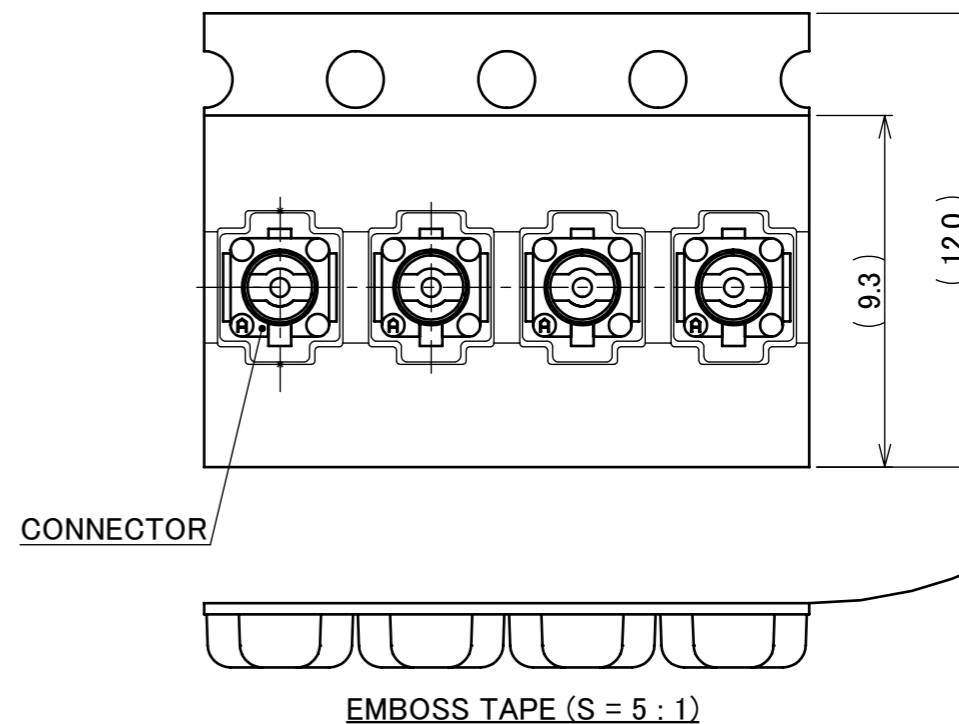
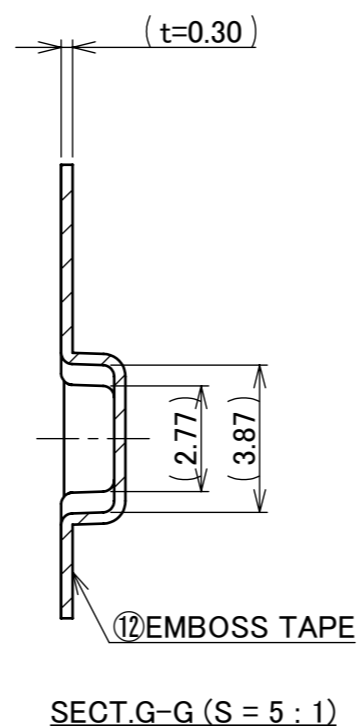
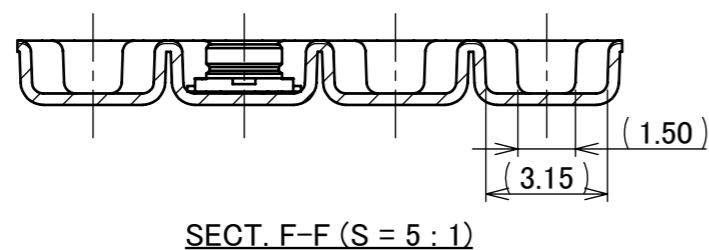
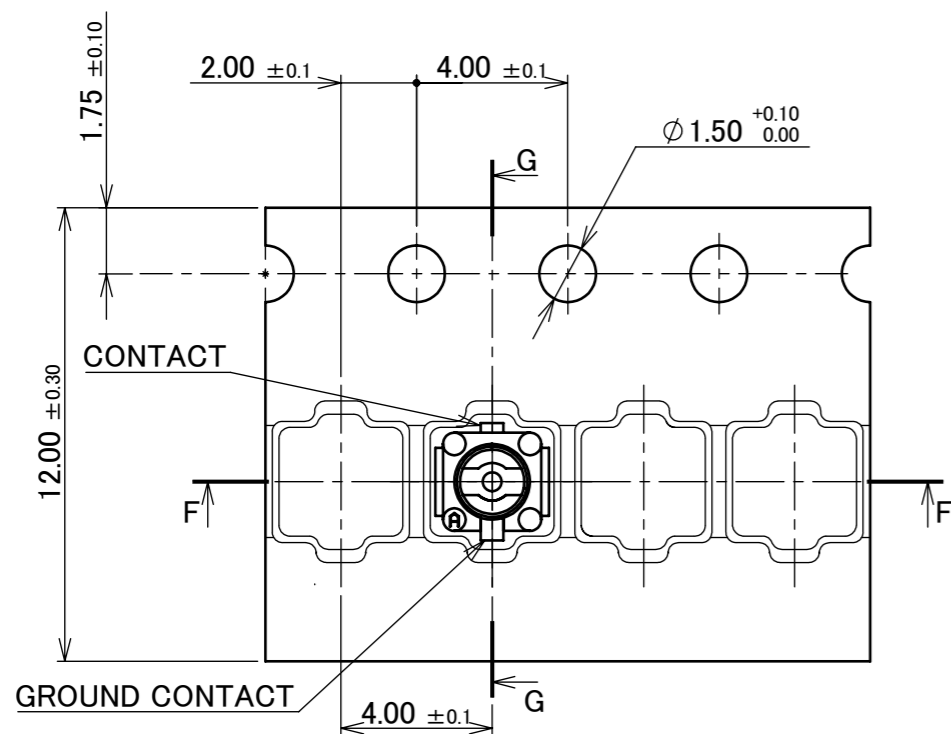
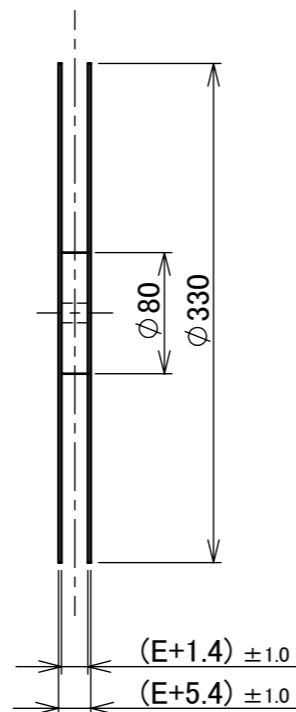
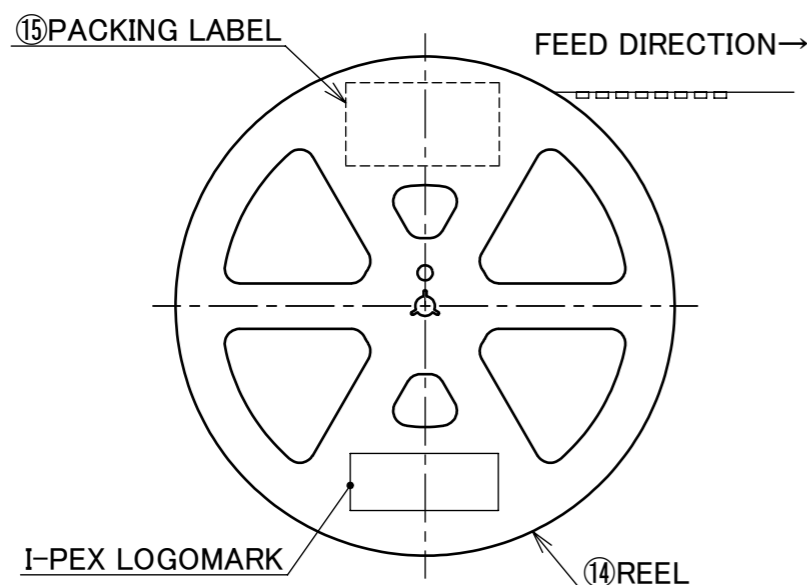

- NOTES.  
13. TAPING SPECIFICATION FOLLOWS JIS C 0806 (IEC 60286-3).  
14. MAKE EMPTY SECTION OF LEADER AND END ON EACH END OF THE TAPE.  
15. TOP TAPE SHALL NOT STICK OUT FROM EMBOSSED TAPING.  
16. TOP TAPE SHALL NOT COVER FEED HOLE.

NO.	DISCRIPTION	MATERIAL	FINISH , REMARKS
15	PACKING LABEL	-	-
14	REEL	PS	ANTI-STATIC TYPE
13	TOP TAPE	PET	ANTI-STATIC TYPE HEAT ACTIVATED COVER
12	EMBOS TAPE	PS	ANTI-STATIC TYPE

ANGLE	$\pm 2^\circ$	6 OVER 30 MAX.	$\pm 0.3$	PROJECTION		SERIES No.	R9	CUSTOMER COPY						
6 MAX.	$\pm 0.2$	30 OVER 120 MAX.	$\pm 0.5$	GENERAL TOLERANCE.		TITLE		SCALE	<b>I-PEX</b>					
DWG.	DATE		MHF® I/II RECEPTACLE		UNIT	mm								
CHK.			DWG. No.		SIZE							SHEET 8/9 REV. 31		
APP.			20279		SIZE									





MHF I SMA ADAPTER  
PART NO. 90193-002

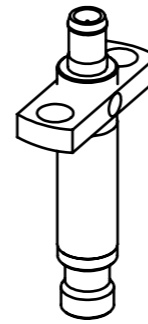

MHF I RECEPTACLE HIGH CYCLE N45 C ADAPTER  
PART NO. 90575-0001

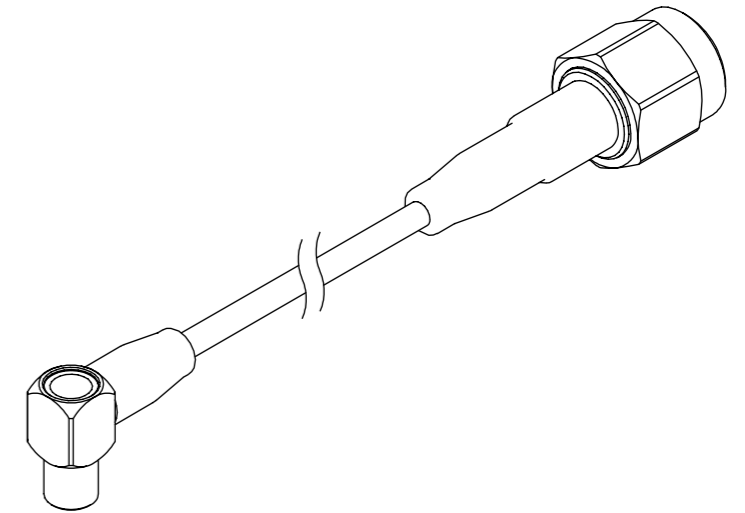

MHF SERIES N45 C TO SMA ADAPTER CABLE  
PART NO. 90577-\*\*\*\*

\* 90575-0001 AND 90577-\*\*\*\* SHOULD BE USED TOGETHER.

ANGLE	±2°	6 OVER 30 MAX.	±0.3	PROJECTION ⊕	SERIES No. R9	CUSTOMER COPY			
6 MAX.	±0.2	30 OVER 120 MAX.	±0.5						
GENERAL TOLERANCE.				TITLE		SCALE	<b>I-PEX</b>		
DWG.	DATE			MHF® I/II RECEPTACLE		2:1			
CHK.						UNIT			
APP.				DWG. No. 20279		mm			
						SIZE	SHEET	REV.	
						A3	9/9	31	