

PART No.
20351-1**R-37

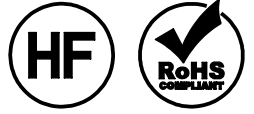

NOTES

- APPLICABLE CONNECTOR:  
20279-001E-\*\*, 20431-001E-01, 20441-001E-01
- PERMISSIBLE LOAD OF CABLE AT MATING
- SUGGESTIONS FOR MATING & UNMATING OPERATION
  - MATING  
PLEASE MATE THE CONNECTOR STRAIGHTLY TO VERTICAL DIRECTION AS MUCH AS POSSIBLE, ADJUSTING THE MATING AXIS OF PLUG AND RECEPTACLE. AS EXCESSIVE SLANT ANGLE MATING MAY BREAK THE CONNECTOR, PLEASE DON'T DO IT.
  - UNMATING
    - IN CASE OF UNMATING BY PULLING TOOL  
PLEASE USE THE PULLING TOOL AS THE FOLLOWING DRAWING, AND PLEASE PULL PLUG TO VERTICAL DIRECTION AS DIRECTLY AS POSSIBLE.
    - IN CASE OF UNMATING DIRECTLY BY HAND  
PLEASE CATCH THE CATCHING AREA OF PLUG, AND PLEASE PULL PLUG TO VERTICAL DIRECTION AS DIRECTLY AS POSSIBLE.
  - CRIMP OVER STANDARDS OF OUTER CONDUCTOR  
STANDARDS: LESS THAN 10% FROM TOTAL NUMBERS OF OUTER CONDUCTOR.  
(NUMBERS OF OUTER CONDUCTOR'S CRIMP OVER FROM OUTER CONDUCTOR'S BARREL)
  - CAUTION ABOUT HEAT SHRINKAGE TUBES  
PLEASE BE CAREFUL NOT TO MELT HOUSING WHEN USING HEAT SHRINKAGE TUBES. IT WILL BECOME CAUSE OPEN CIRCUIT.
- TIP OF CONTACT SHOULD BE RECESSED OF HOUSING AFTER CRIMPED ABOUT MATING AREA.
- THIS IS "Pb-FREE" CONNECTOR.

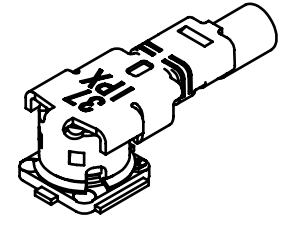
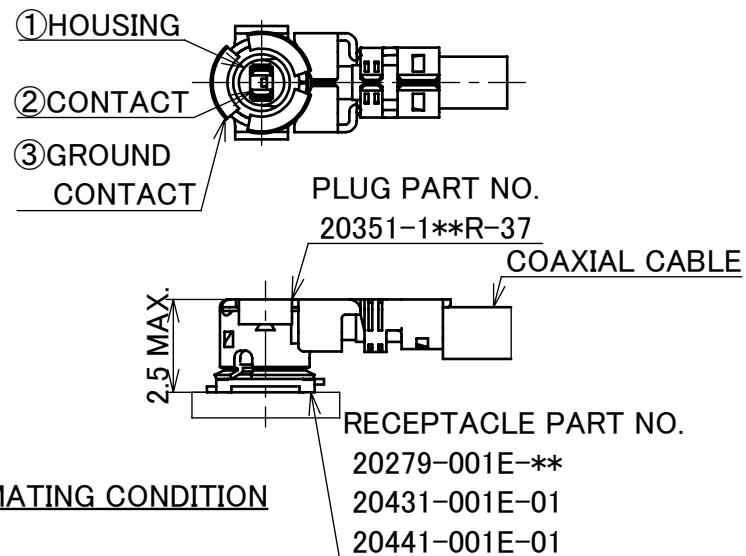
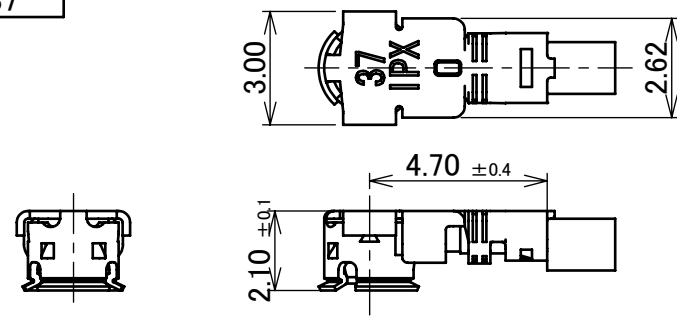
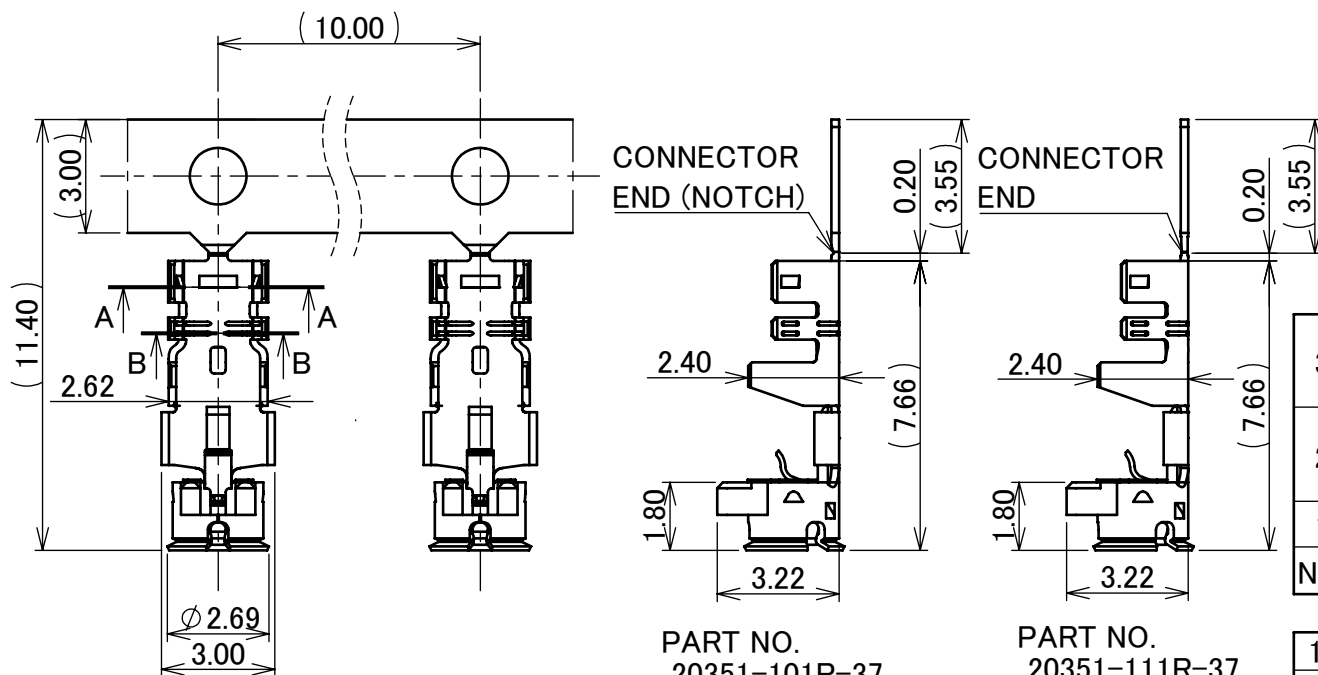

PART NO.  
20351-101R-37  
20351-102R-37

FOR HAND TOOL  
(WITH NOTCH)

PART NO.  
20351-111R-37  
20351-112R-37

FOR SEMI AUTO  
TERMINATION  
MACHINE  
(WITHOUT NOTCH)

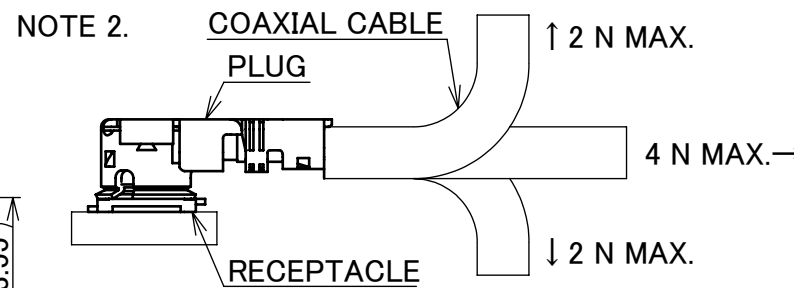

NOTE 3-2-1.

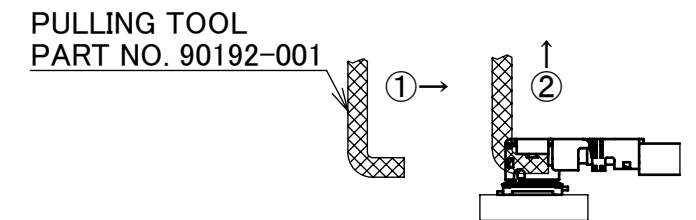

NOTE 3-2-2.

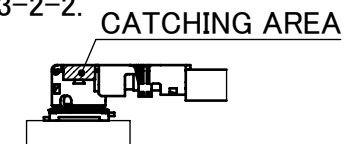

NO.	DESCRIPTION	MATERIAL	FINISH , REMARKS
3	GROUND CONTACT	PHOSPHOR BRONZE	ALL OVER Ni 1.00 μm MIN. CONTACT PART Au 0.05 μm MIN.
2	CONTACT	PHOSPHOR BRONZE	ALL OVER Ni 1.00 μm MIN. CONTACT PART Au 0.10 μm MIN.
1	HOUSING	PBT	UL94V-0, WHITE

REV.	ECN	BY	DATE	APP.	APP.	CHK.	DATE	DATE	ANGLE	±2°	6 OVER 30 MAX.	±0.3	PROJECTION	SERIES No.	CUSTOMER COPY		
18	Z210168	S.T	2021/02/19	M.T					±2°	6 OVER 30 MAX.	±0.3	PROJECTION	R8	CUSTOMER COPY			
17	Z200262	TOI	2020/03/05	Y.H				6 MAX.	±0.2	30 OVER 120 MAX.	±0.5	PROJECTION	R8				
16	Z191013	Haji	2019/08/01	Y.S					GENERAL TOLERANCE.			TITLE	SCALE	I-PEX			
15	Z181501	M.N	2018/11/15	Ken	DWG.							MHF® I	5:1				
14	Z171151	M.A	2017/10/05	T.M		T.Hirakawa	2003/09/11					PLUG (1.37)	UNIT				
13	Z150615	Tad	2015/06/04	Tom	CHK.								mm				
					APP.	T.Harada							SIZE				
REVISION RECORD										K.Katabuchi			DWG. No.	20351	SIZE	SHEET	REV.
															A3	1/5	18

ITEMS	SPECIFICATION
RECOMMENDED APPLICABLE CONNECTOR PART No.	20279-001E-**
RATING VOLTAGE	60 V AC (R.M.S)
RATING FREQUENCY	DC~9GHz
OPERATING TEMPERATURE	233~363 K (-40°C~+90°C)
VSWR	1.3 MAX. AT 0.1~3 GHz, 1.5 MAX. AT 3~6 GHz, 1.9 MAX. AT 6~9 GHz
MAIN CONTACT RESISTANCE	INITIAL: 20 mohm MAX. / AFTER TEST: 25 mohm MAX.
GROUND CONTACT RESISTANCE	INITIAL: 10 mohm MAX. / AFTER TEST: 15 mohm MAX.
INSULATION RESISTANCE	INITIAL: 500 Mohm MIN. / AFTER TEST: 100 Mohm MIN.
DIELECTRIC WITHSTANDING VOLTAGE	200 V AC, 1 MINUTE
DURABILITY	30 CYCLES
UNMATING FORCE (INITIAL / AFTER TEST)	5 N MIN. / 3 N MIN.
CRIMP STRENGTH	15 N MIN.
PRODUCT SPECIFICATION	PRS-1726
TEST REPORT	TR-12096
PACKING STANDARD	300-233
INSTRUCTION MANUAL	HIM-10002
APPEARANCE CRITERIA No.	QLS-A***

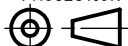
ANGLE	±2°	6 OVER 30 MAX.	±0.3	PROJECTION 	SERIES No. R8	CUSTOMER COPY			
6 MAX.	±0.2	30 OVER 120 MAX.	±0.5						
GENERAL TOLERANCE.				TITLE MHF® I PLUG (1.37)	SCALE 5:1	<b>I-PEX</b>			
DWG.	DATE								UNIT mm
CHK.									SIZE A3
APP.									SHEET 2/5
				DWG. No. 20351					

PART NO. OF NON HALOGEN FREE TYPE	20351-101R-37	20351-111R-37
-----------------------------------	---------------	---------------

PART NO. OF HALOGEN FREE TYPE	20351-102R-37	20351-112R-37
-------------------------------	---------------	---------------

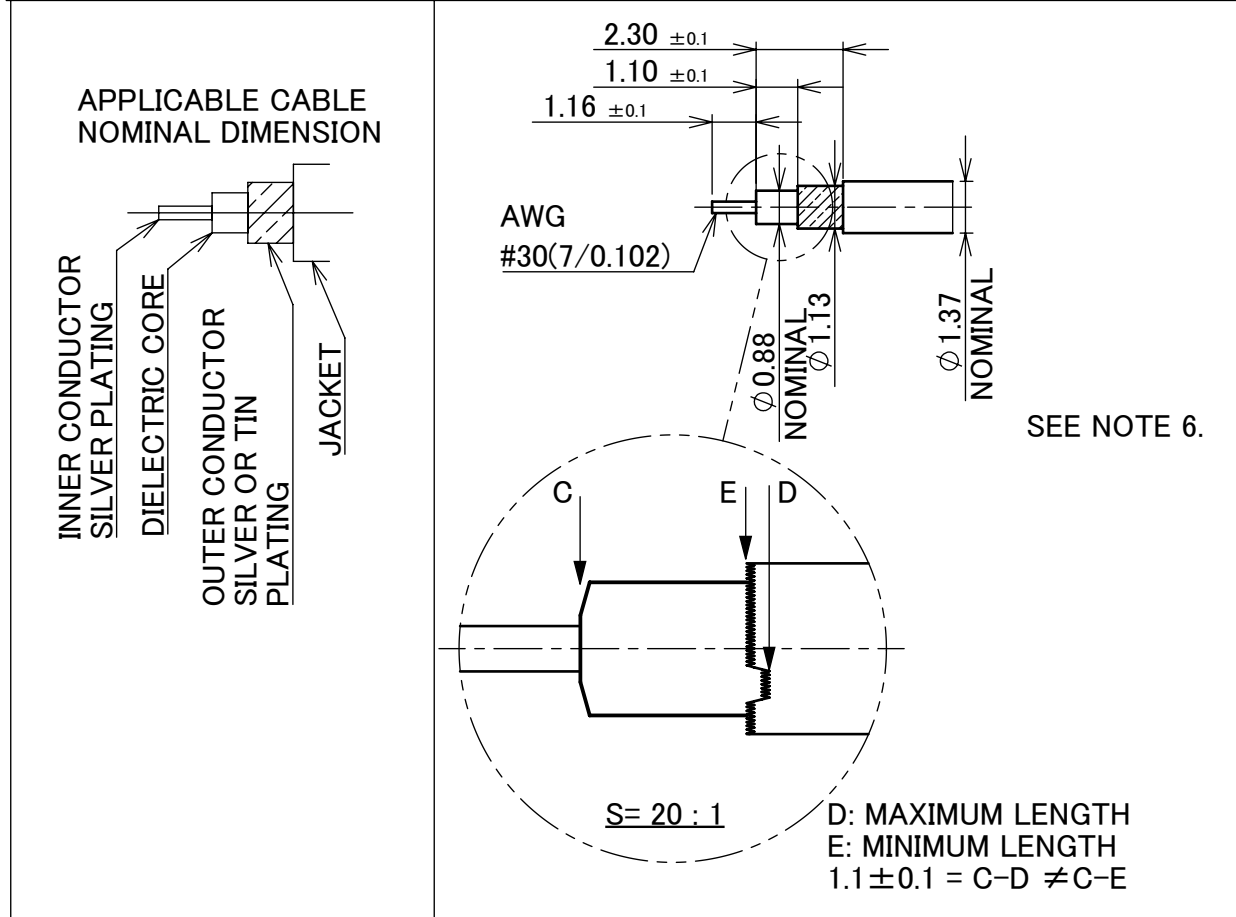

BRAIDED SHIELD OF OUTER CONDUCTOR	SINGLE	
-----------------------------------	--------	--

PART NO. OF HAND TOOL	90233-037	PART NO. OF SEMI AUTO TERMINATION MACHINE	90232-037
-----------------------	-----------	---	-----------

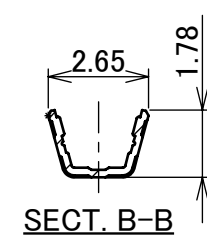
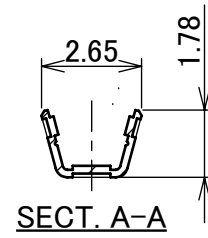

CRIMP HEIGHT	CH-1	1.34~1.40
	CH-2	1.36~1.42
	CH-3	1.28~1.34

NOTE 6. MUST NOT USE SOLDER COATED INNER CONDUCTOR.

CABLE CUT LENGTH

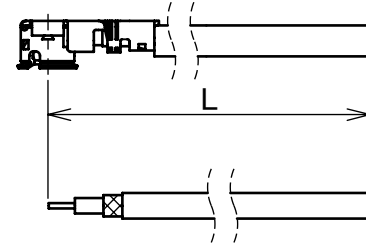

CRIMP HEIGHT

BLADE MICROMETER

CH-1

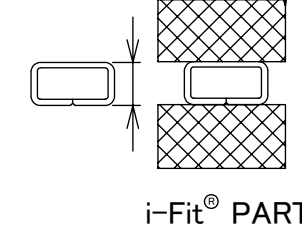

i-Fit® PART

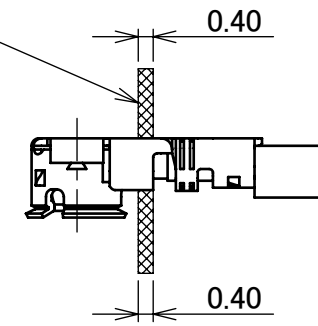

CH-2

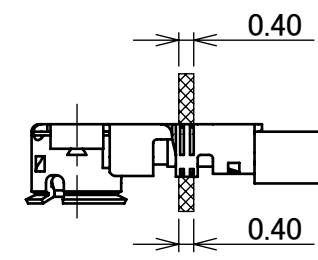
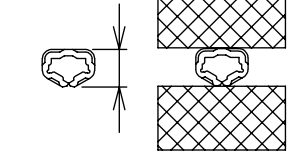

OUTER CONDUCTOR PART

CH-3

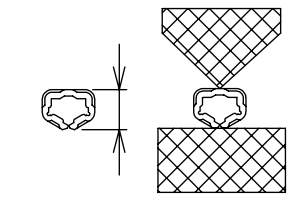

JACKET PART

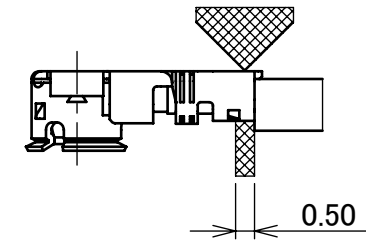

ANGLE	±2°	6 OVER 30 MAX.	±0.3	PROJECTION	SERIES No.	CUSTOMER COPY				
	6 MAX.	±0.2	30 OVER 120 MAX.	±0.5	R8	SCALE	I-PEX			
GENERAL TOLERANCE.						TITLE				5:1
DWG.	DATE					MHF® I PLUG (1.37)				UNIT
CHK.						DWG. No.	mm	SIZE	SHEET	REV.
APP.						20351	A3	3/5	18	

Recommended P/N 20351-112R-37

PART NO.	F	QTY. PER EMBOSS REEL (PIECES / REEL)	QTY. PER PACKING CARTON (REELS / CARTON)
20351-1**R-37	16.0	2,500 / REEL	5 REELS / CARTON = 12,500 PIECES

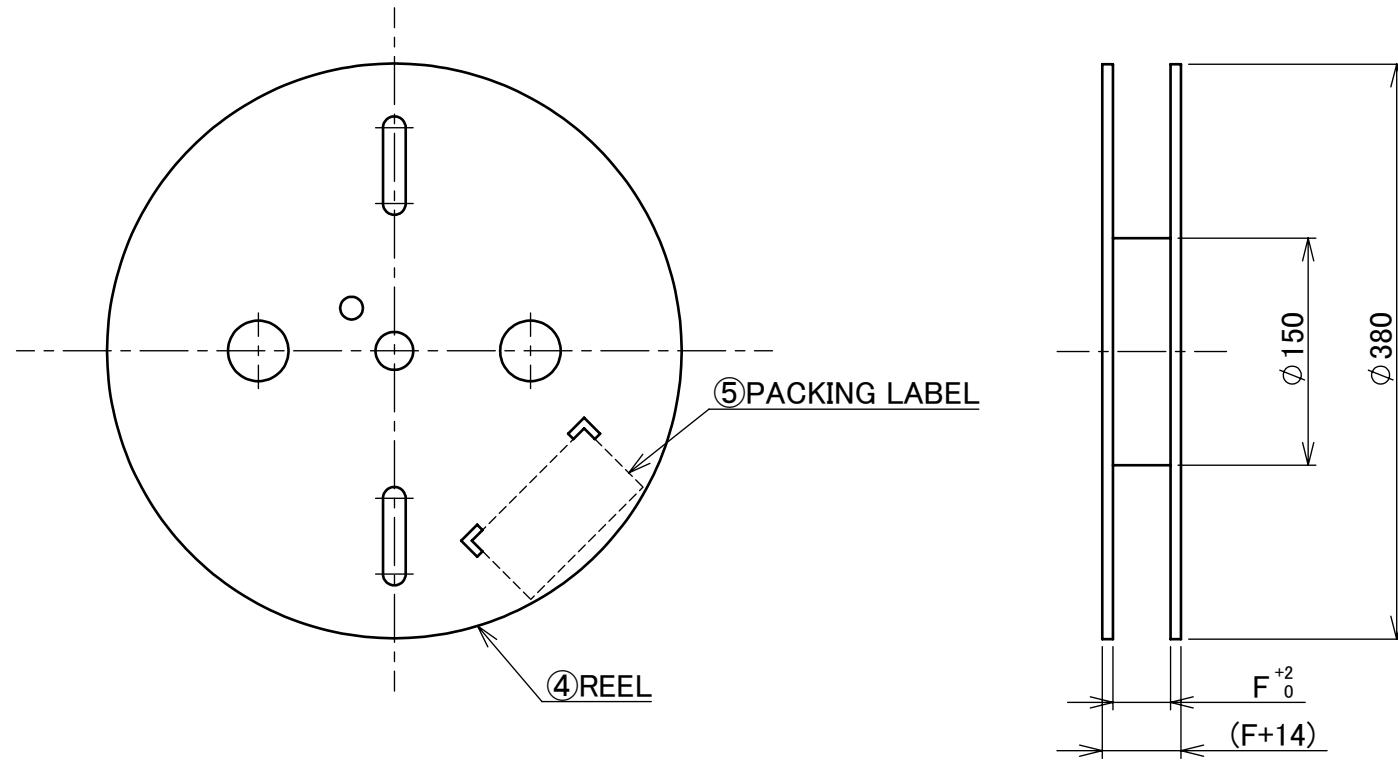

5	PACKING LABEL	-	-
4	REEL	CB	-
NO.	DISCRIPTION	MATERIAL	FINISH , REMARKS

ANGLE	$\pm 2^\circ$	6 OVER 30 MAX.	$\pm 0.3$	PROJECTION 	SERIES No. R8	CUSTOMER COPY		
6 MAX.	$\pm 0.2$	30 OVER 120 MAX.	$\pm 0.5$					
GENERAL TOLERANCE.				TITLE MHF® I PLUG (1.37)	SCALE 1:1	<b>I-PEX</b>		
DWG.	DATE							
CHK.								
APP.								
				DWG. No.	20351	SIZE A3	SHEET 4/5	REV. 18

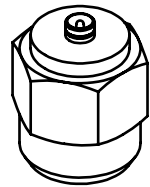

MHF I/II SMA ADAPTOR  
PART NO. 90193-001

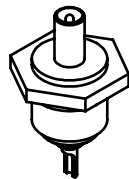

MHF I/II PLUG INSPECTION CONNECTOR  
PART NO. 90194-001

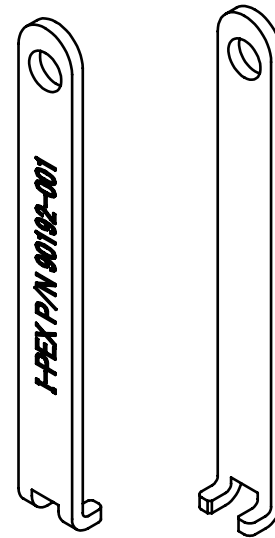

FRONT SIDE    BACK SIDE  
MHF I/II PULLING TOOL  
PART NO. 90192-001

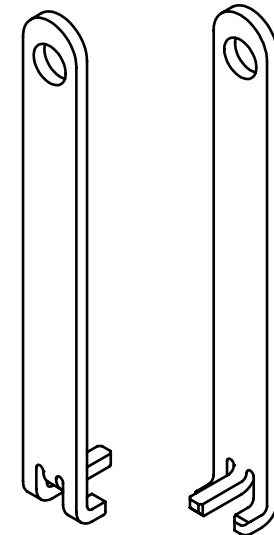

FRONT SIDE    BACK SIDE  
MHF I PUSHING AND PULLING TOOL  
PART NO. 90224-001

ANGLE	±2°	6 OVER 30 MAX.	±0.3	PROJECTION ⊕	SERIES No. R8	CUSTOMER COPY			
6 MAX.	±0.2	30 OVER 120 MAX.	±0.5						
GENERAL TOLERANCE.				TITLE		SCALE	<b>I-PEX</b>		
DWG.	DATE			MHF® I PLUG (1.37)		2:1			
CHK.						UNIT			
APP.				DWG. No. 20351		mm			
						SIZE	SHEET	REV.	
						A3	5/5	18	