

Recommended P/N 20279-001E-03

PART NO.	PACKING REEL	QUANTITY IN 1 REEL
20279-001E-01	PLASTIC REEL	2,500
	CORRUGATED PAPER REEL	2,500
20279-001E-03	PLASTIC REEL	5,000
20279-001E-05	PLASTIC REEL	10,000

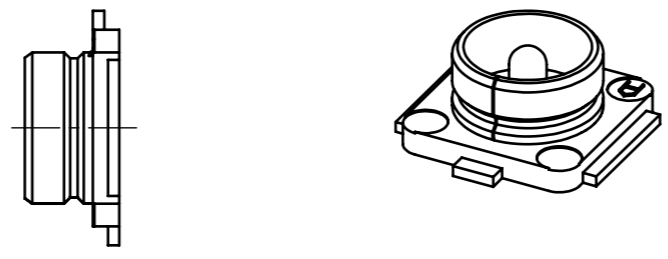

- NOTES
- APPLICABLE CONNECTOR PART NO.
 MHF I PLUG
 20278-11*R-**
 20351-***R-37
 20631-***R-**
 20670-001R-**
 20767-001R-20
 MHF II PLUG
 20311-011R-**
 20686-001R-08
 - COPLANARITY: 0.1mm MAX.
 - THIS IS "Pb-FREE" CONNECTOR.

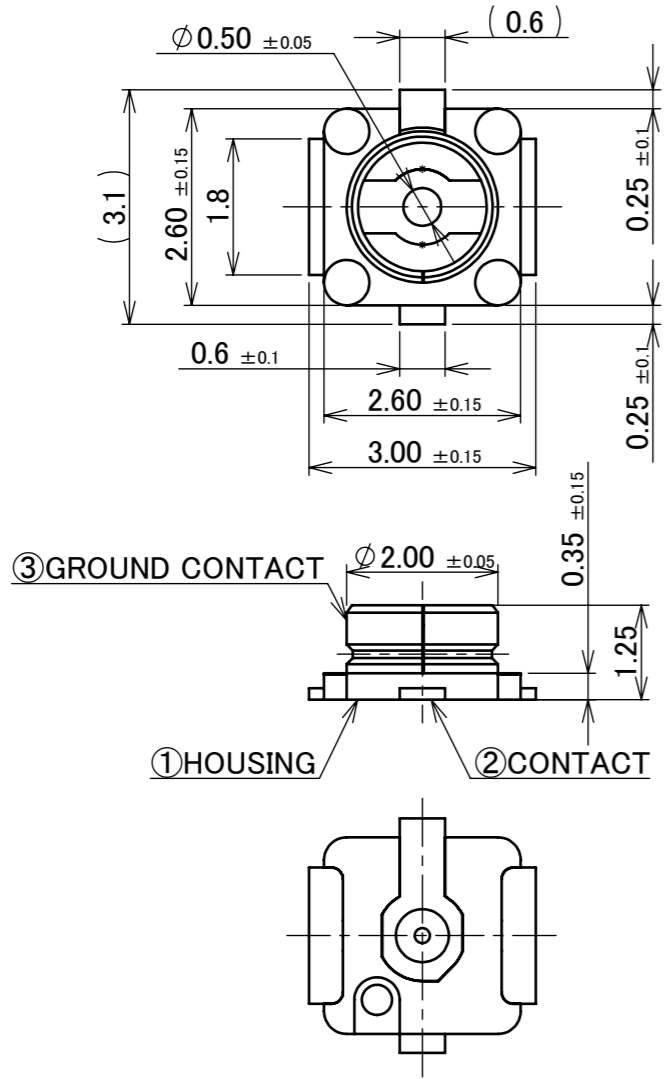
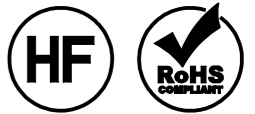
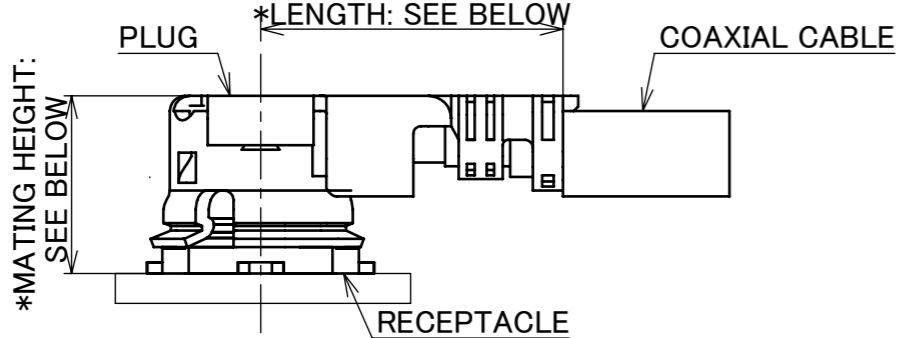

*LENGTH: 4.0±0.4 AT PLUG PART NO. 20670-001R-08, 20670-001R-13, 20670-001R-32
 4.7±0.4 AT PLUG PART NO. 20670-001R-18, 20670-001R-37
 5.6 AT PLUG PART NO. 20767-001R-20 (REFERENCE DIMENSION)
 3.8±0.3 AT PLUG PART NO. 20686-001R-08, 20311-011R-**

*MATING HEIGHT: 2.5 MAX. AT PLUG PART NO. 20670-001R-**
 3.0 MAX. AT PLUG PART NO. 20767-001R-20
 2.0±0.1 AT PLUG PART NO. 20686-001R-08, 20311-011R-**

MATING CONDITION

NO.	DISCRIPTION	MATERIAL	FINISH , REMARKS
3	GROUND CONTACT	PHOSPHOR BRONZE	ALL OVER Ni 1.00 μm MIN. CONTACT PART Au 0.05 μm MIN. SOLDERING PART Au 0.05 μm MIN.
2	CONTACT	BRASS	ALL OVER Ni 1.00 μm MIN. CONTACT PART Au 0.10 μm MIN. SOLDERING PART Au 0.03 μm MIN.
1	HOUSING	LCP	UL94V-0, WHITE

REV.	ECN	BY	DATE	APP.	APP.	DATE	DWG. No.	SIZE	SHEET	REV.	
27	Z210232	S.T	2021/03/08	M.T	ANGLE	±2°	6 OVER 30 MAX.	±0.3	PROJECTION ⊕	SERIES No. R9	CUSTOMER COPY
26	Z200434	TOI	2020/04/20	Y.H	6 MAX.	±0.2	30 OVER 120 MAX.	±0.5			
25	Z200262	TOI	2020/03/05	Y.H	GENERAL TOLERANCE.			TITLE MHF® I/II RECEPTACLE	SCALE	I-PEX	
24	Z191405	Y.F	2019/10/23	Y.S	DWG.	DATE	2001/06/07		10:1		
23	Z181523	M.N	2018/11/20	Ken	K.Oobayashi				2001/06/07		UNIT
22	Z180765	M.N	2018/10/30	Ken	CHK.	E.Kawabe					mm
REV.	ECN	BY	DATE	APP.	APP.	DATE	DWG. No.	A3	1/8	27	

Recommended P/N	20279-001E-03	
PART NO.	PACKING REEL	QUANTITY IN 1 REEL
20279-001E-06	PLASTIC REEL	10,000

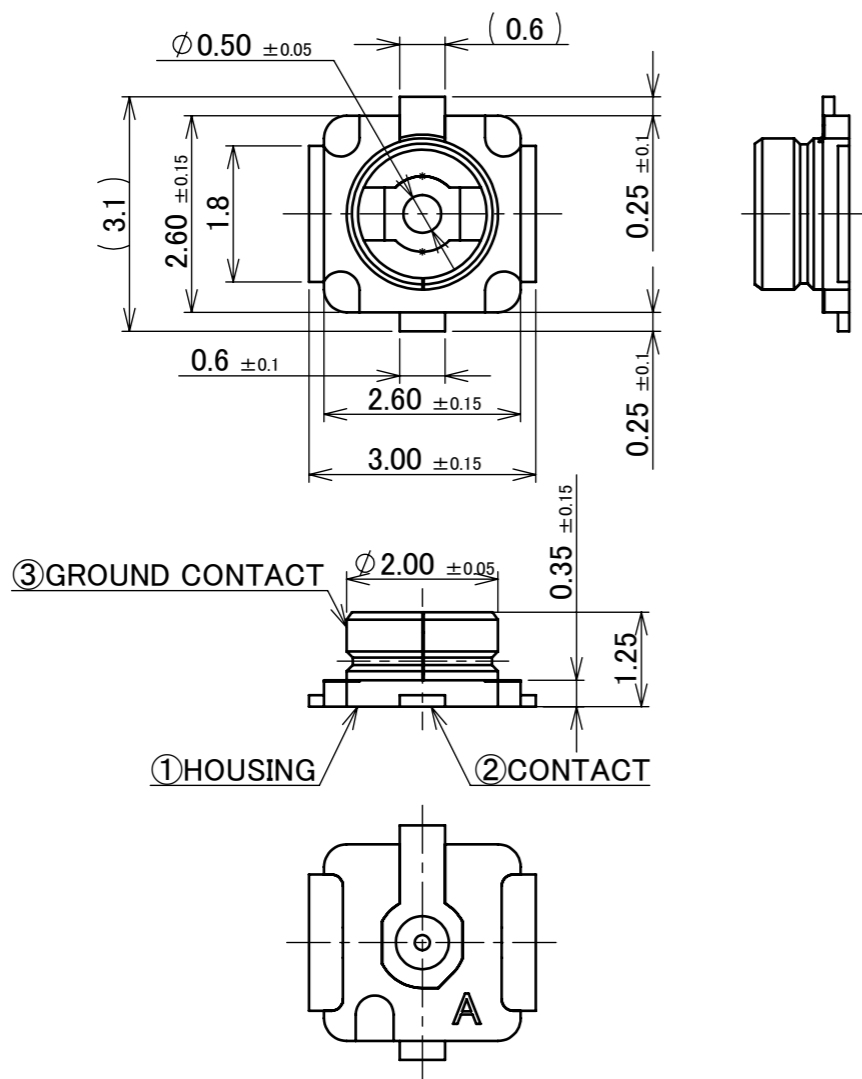

NOTES

1. APPLICABLE CONNECTOR PART NO.
 MHF I PLUG
 20278-11*R-**
 20351-***R-37
 20631-***R-**
 20670-001R-**
 20767-001R-20
 MHF II PLUG
 20311-011R-**
 20686-001R-08
2. COPLANARITY: 0.1mm MAX.
3. THIS IS "Pb-FREE" CONNECTOR.

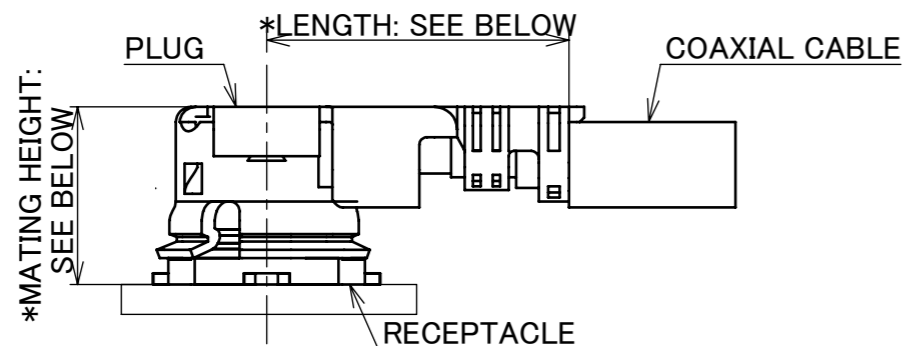

- *LENGTH: 4.0 ±0.4 AT PLUG PART NO. 20670-001R-08, 20670-001R-13, 20670-001R-32
 4.7 ±0.4 AT PLUG PART NO. 20670-001R-18, 20670-001R-37
 5.6 AT PLUG PART NO. 20767-001R-20 (REFERENCE DIMENSION)
 3.8 ±0.3 AT PLUG PART NO. 20686-001R-08, 20311-011R-**
- *MATING HEIGHT: 2.5 MAX. AT PLUG PART NO. 20670-001R-**
 3.0 MAX. AT PLUG PART NO. 20767-001R-20
 2.0 ±0.1 AT PLUG PART NO. 20686-001R-08, 20311-011R-**

MATING CONDITION

NO.	DISCRIPTION	MATERIAL	FINISH , REMARKS
3	GROUND CONTACT	PHOSPHOR BRONZE	ALL OVER Ni 1.00 μ m MIN. CONTACT PART Au 0.05 μ m MIN. SOLDERING PART Au 0.05 μ m MIN.
2	CONTACT	BRASS	ALL OVER Ni 1.00 μ m MIN. CONTACT PART Au 0.10 μ m MIN. SOLDERING PART Au 0.03 μ m MIN.
1	HOUSING	LCP	UL94V-0, WHITE

ANGLE	±2°	6 OVER 30 MAX.	±0.3	PROJECTION ⊕	SERIES No. R9	CUSTOMER COPY			
6 MAX.	±0.2	30 OVER 120 MAX.	±0.5			SCALE 10:1	I-PEX		
GENERAL TOLERANCE.				TITLE MHF® I/II RECEPTACLE		UNIT mm			
DWG.	DATE			DWG. No. 20279		SIZE A3	REV. 27		
CHK.									
APP.									

ITEMS	SPECIFICATION		
RECOMMENDED APPLICABLE CONNECTOR PART NO.	20670-001R-** (MHF I PLUG Ni TOP 1.80, 1.37, 1.32, 1.13, 0.81)	20767-001R-20 (MHF I PLUG 2.00)	20686-001R-08 (MHF II PLUG Ni TOP 0.81)
RATING VOLTAGE	60 V AC (R.M.S)		
RATING FREQUENCY	DC~9GHz		
OPERATING TEMPERATURE	233~363K (-40°C~+90°C)		
VSWR	RECEPTACLE: 1.3 MAX. AT 0.1~3 GHz, 1.4 MAX. AT 3~6 GHz, 1.8 MAX. AT 6~9 GHz		
MAIN CONTACT RESISTANCE	INITIAL: 20 mohm MAX. / AFTER TEST: Δ R 20 mohm MAX.		
GROUND CONTACT RESISTANCE	INITIAL: 20 mohm MAX. / AFTER TEST: Δ R 100 mohm MAX.		
INSULATION RESISTANCE	INITIAL: 500 Mohm MIN. / AFTER TEST: 100 Mohm MIN.		
DIELECTRIC WITHSTANDING VOLTAGE	200 V AC, 1 MINUTE		
DURABILITY	30 CYCLES		
UNMATING FORCE (INITIAL / AFTER TEST)	INITIAL: 5 N MIN. AFTER TEST: 3 N MIN.		INITIAL: 4 N MIN. AFTER TEST: 2 N MIN.
PRODUCT SPECIFICATION	PRS-2105	PRS-2490	PRS-2106
TEST REPORT	TR-15059	TR-18041	TR-15060
PACKING STANDARD	20279-001E-01: 300-232 (CORRUGATED PAPER REEL) PST-12002 (ANTI-STATIC PLASTIC REEL) 20279-001E-03: 300-850 20279-001E-05: PST-13040 20279-001E-06: PST-13040		
INSTRUCTION MANUAL	HIM-10002		HIM-12010
APPEARANCE CRITERIA No.	QLS-A***		

※UNLESS OTHERWISE SPECIFIED, 20279-001E-01 WILL DERIVED IN CORRUGATED PAPER REELS.
CONTACT YOUR I-PEX SALES IF YOU WISH FOR PLASTIC REELS.

ANGLE	$\pm 2^\circ$	6 OVER 30 MAX.	± 0.3	PROJECTION 	SERIES No. R9	CUSTOMER COPY	
6 MAX.	± 0.2	30 OVER 120 MAX.	± 0.5			SCALE 10:1	UNIT mm
GENERAL TOLERANCE.				TITLE MHF® I/II RECEPTACLE	SIZE A3	SHEET 3/8	
DWG.	DATE			DWG. No.	20279		
CHK.							
APP.							

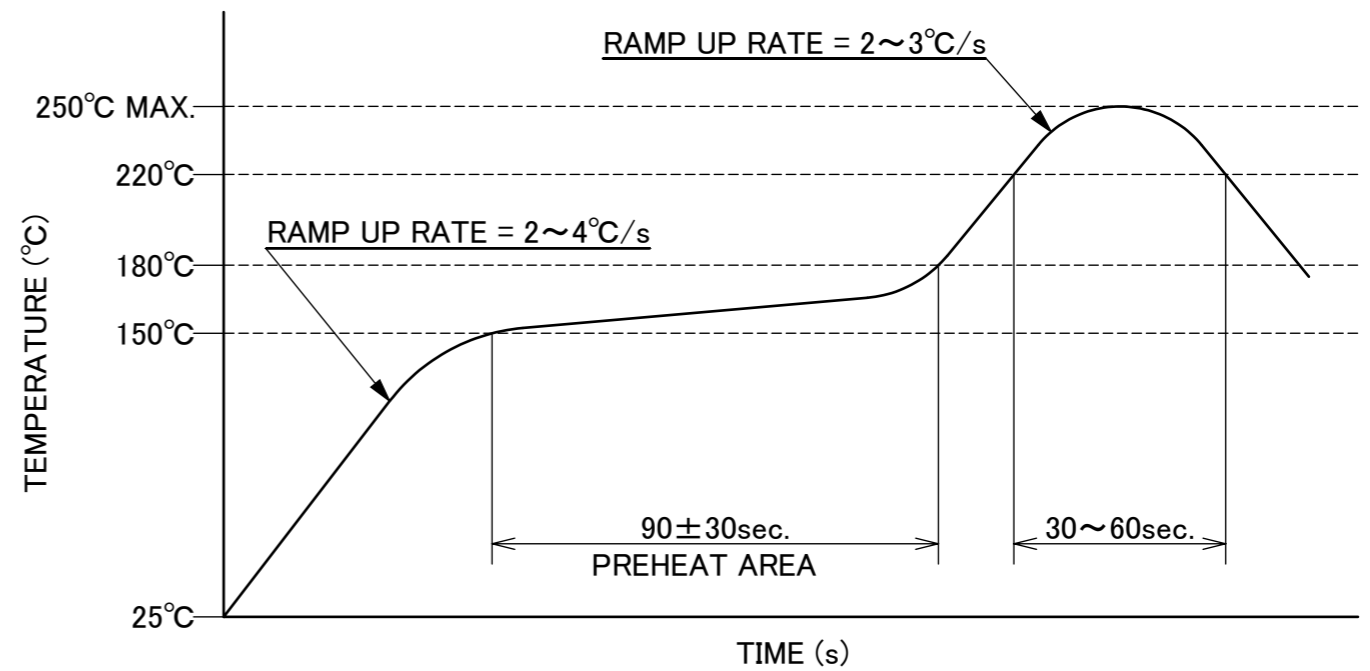
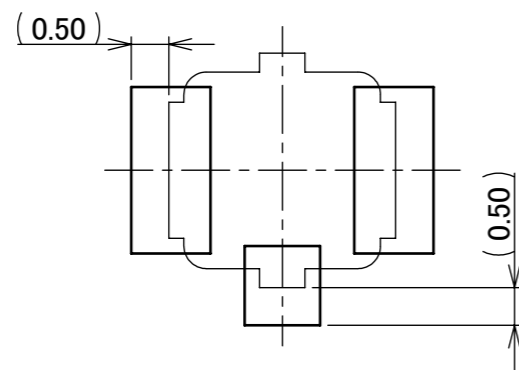
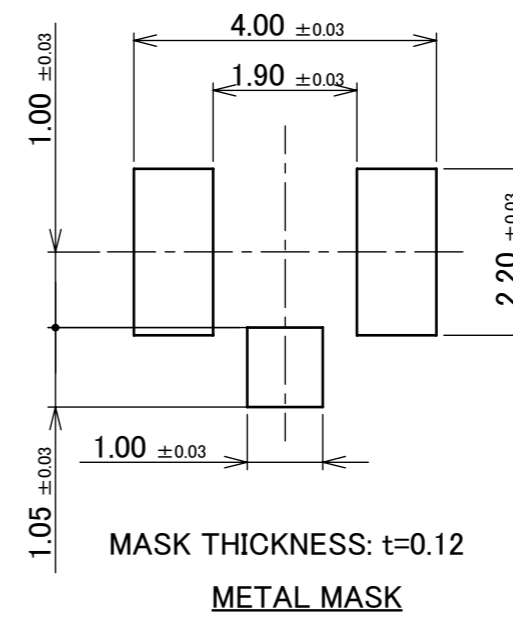
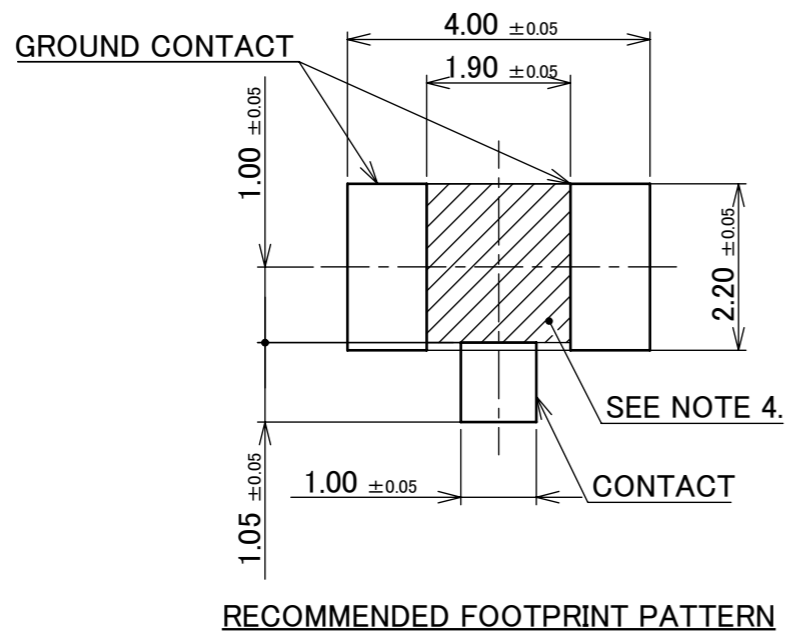

SENJU METAL INDUSTRY CO., LTD. : M705-SHF(Sn96.5 Ag3.0 Cu0.5)

NOTES.
4. CUT OUT PROHIBITION AREA

ANGLE	±2°	6 OVER 30 MAX.	±0.3	PROJECTION ⊕	SERIES No. R9	CUSTOMER COPY			
6 MAX.	±0.2	30 OVER 120 MAX.	±0.5						
GENERAL TOLERANCE.				TITLE		SCALE	I-PEX		
DWG.	DATE			MHF® I/II RECEPTACLE		10:1			
CHK.						UNIT			
APP.				DWG. No.		mm			
				20279		SIZE	SHEET	REV.	
						A3	4/8	27	

PART NO.	A	QTY. PER EMBOSS REEL (PIECES / REEL)	QTY. PER PACKING CARTON (REELS / CARTON)
20279-001E-01	12.4	2,500 / REEL	8 REELS / CARTON = 20,000 PIECES

※UNLESS OTHERWISE SPECIFIED, 20279-001E-01 WILL DERIVED IN CORRUGATED PAPER REELS.
CONTACT YOUR I-PEX SALES IF YOU WISH FOR PLASTIC REELS.

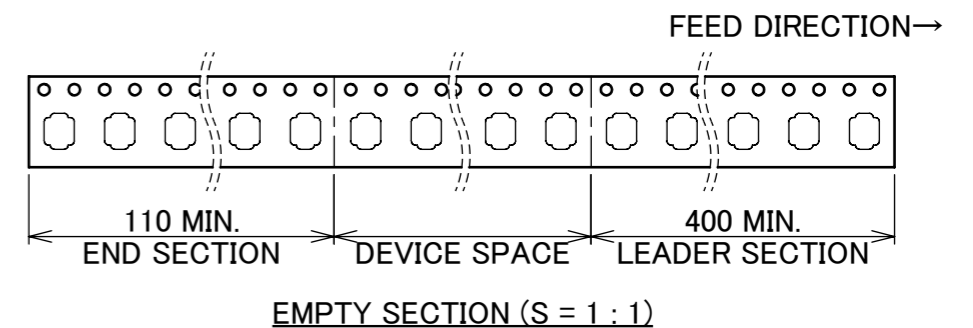
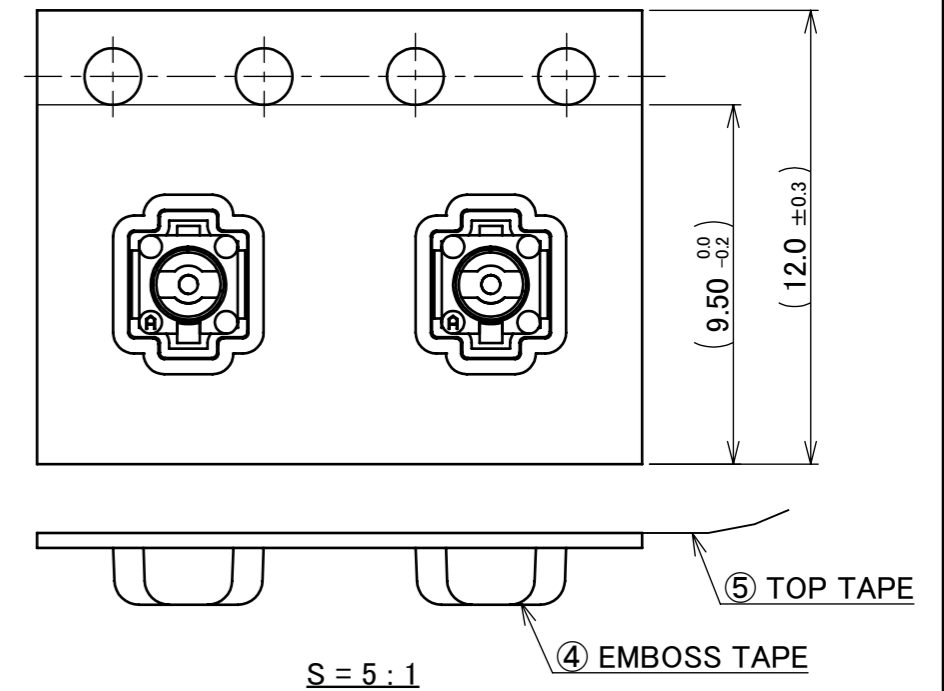
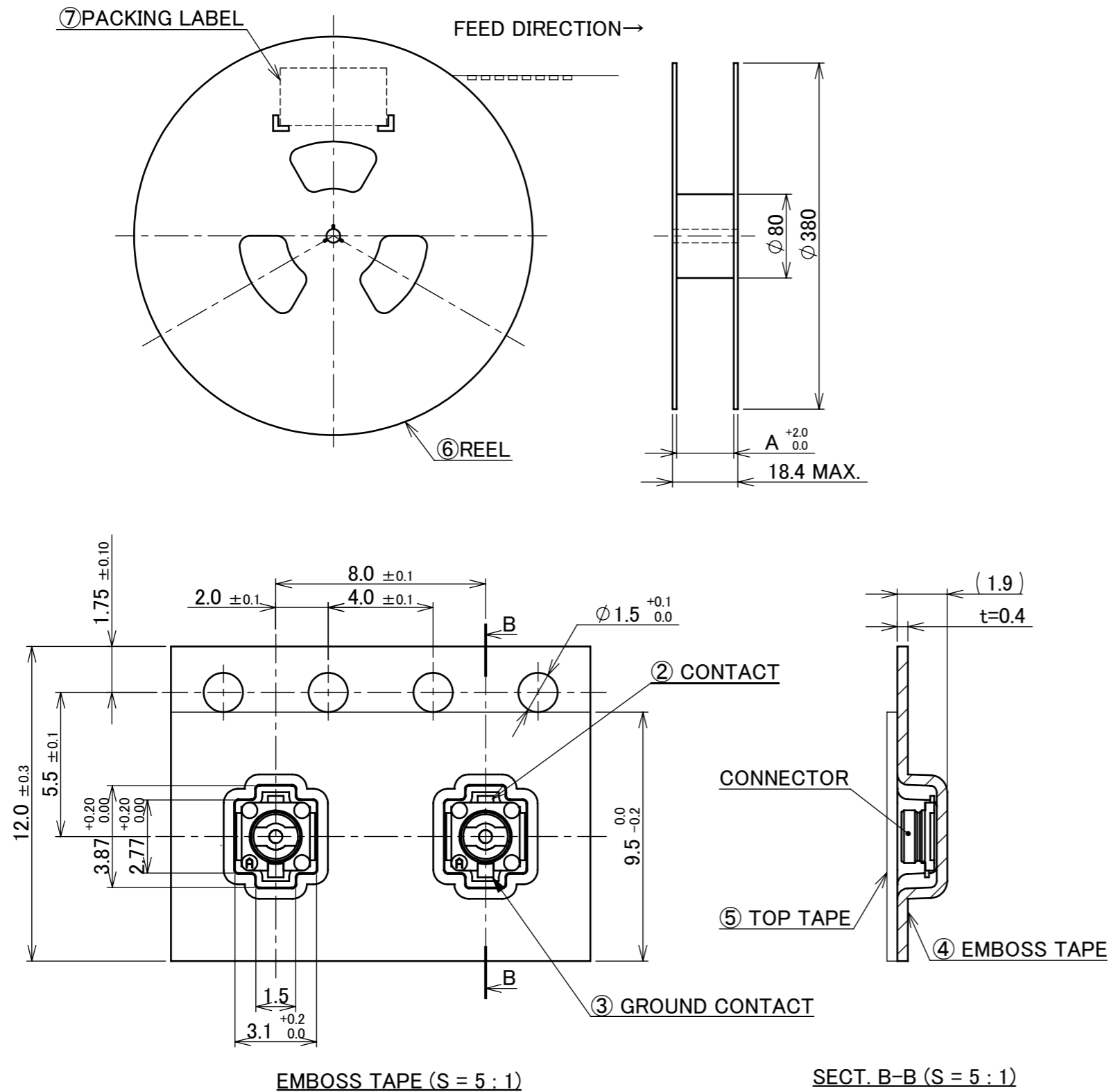

NOTES.

5. TAPING SPECIFICATION FOLLOWS JIS C 0806 (IEC 60286-3).
6. MAKE EMPTY SECTION OF LEADER AND END ON EACH END OF THE TAPE.
7. TOP TAPE SHALL NOT STICK OUT FROM EMBOSSED TAPING.
8. TOP TAPE SHALL NOT COVER FEED HOLE.

NO.	DISCRIPTION	MATERIAL	FINISH , REMARKS
7	PACKING LABEL	-	-
6	REEL	CORRUGATED PAPER	-
5	TOP TAPE	PET t=0.075	-
4	EMBOSS TAPE	PP t=0.4	-

ANGLE	±2°	6 OVER 30 MAX.	±0.3	PROJECTION ⊕	SERIES No. R9	CUSTOMER COPY		
6 MAX.	±0.2	30 OVER 120 MAX.	±0.5					
GENERAL TOLERANCE.				TITLE MHF® I/II RECEPTACLE	SCALE 10:1	UNIT mm I-PEX		
DWG.	DATE							
CHK.								
APP.								
DWG. No. 20279				SIZE A3	SHEET 5/8	REV. 27		

PART NO.	C	QTY. PER EMBOSS REEL (PIECES / REEL)	QTY. PER PACKING CARTON (REELS / CARTON)
20279-001E-01	12.0	2,500 / REEL	8 REELS / CARTON = 20,000 PIECES
20279-001E-03		5,000 / REEL	8 REELS / CARTON = 40,000 PIECES

※UNLESS OTHERWISE SPECIFIED, 20279-001E-01 WILL DERIVED IN CORRUGATED PAPER REELS.
CONTACT YOUR I-PEX SALES IF YOU WISH FOR PLASTIC REELS.

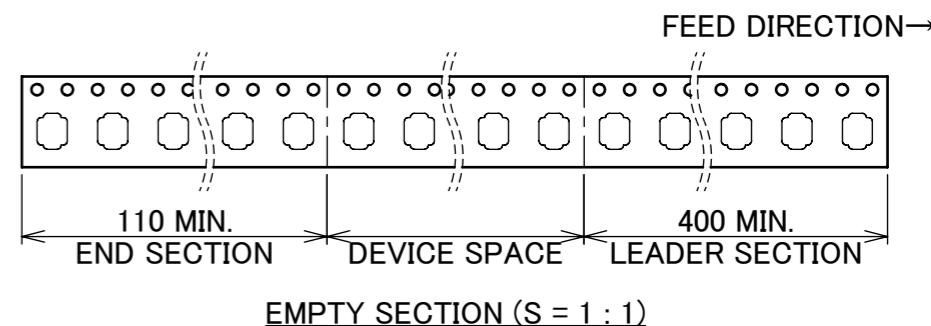
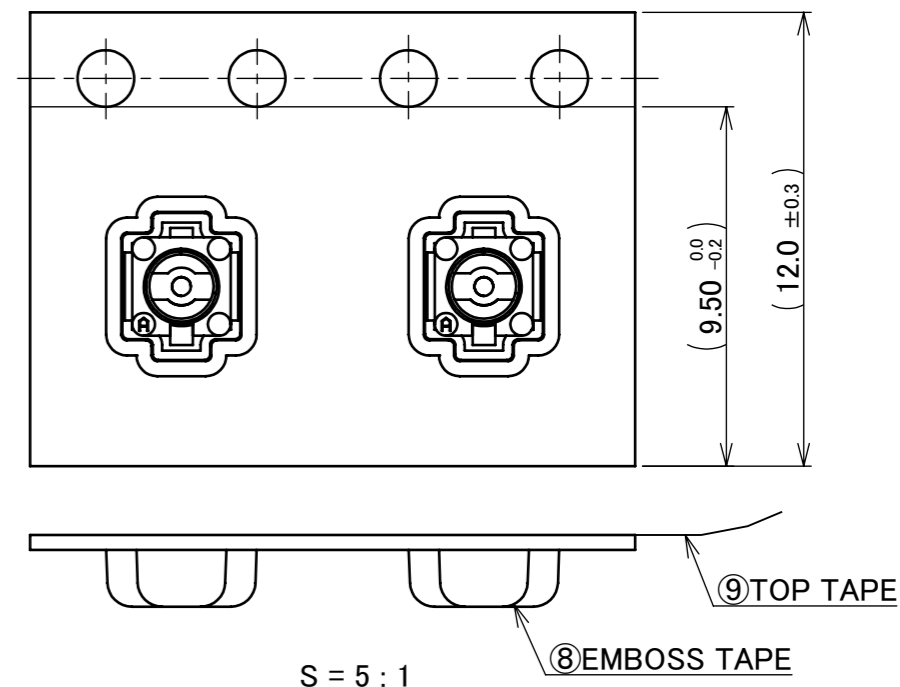
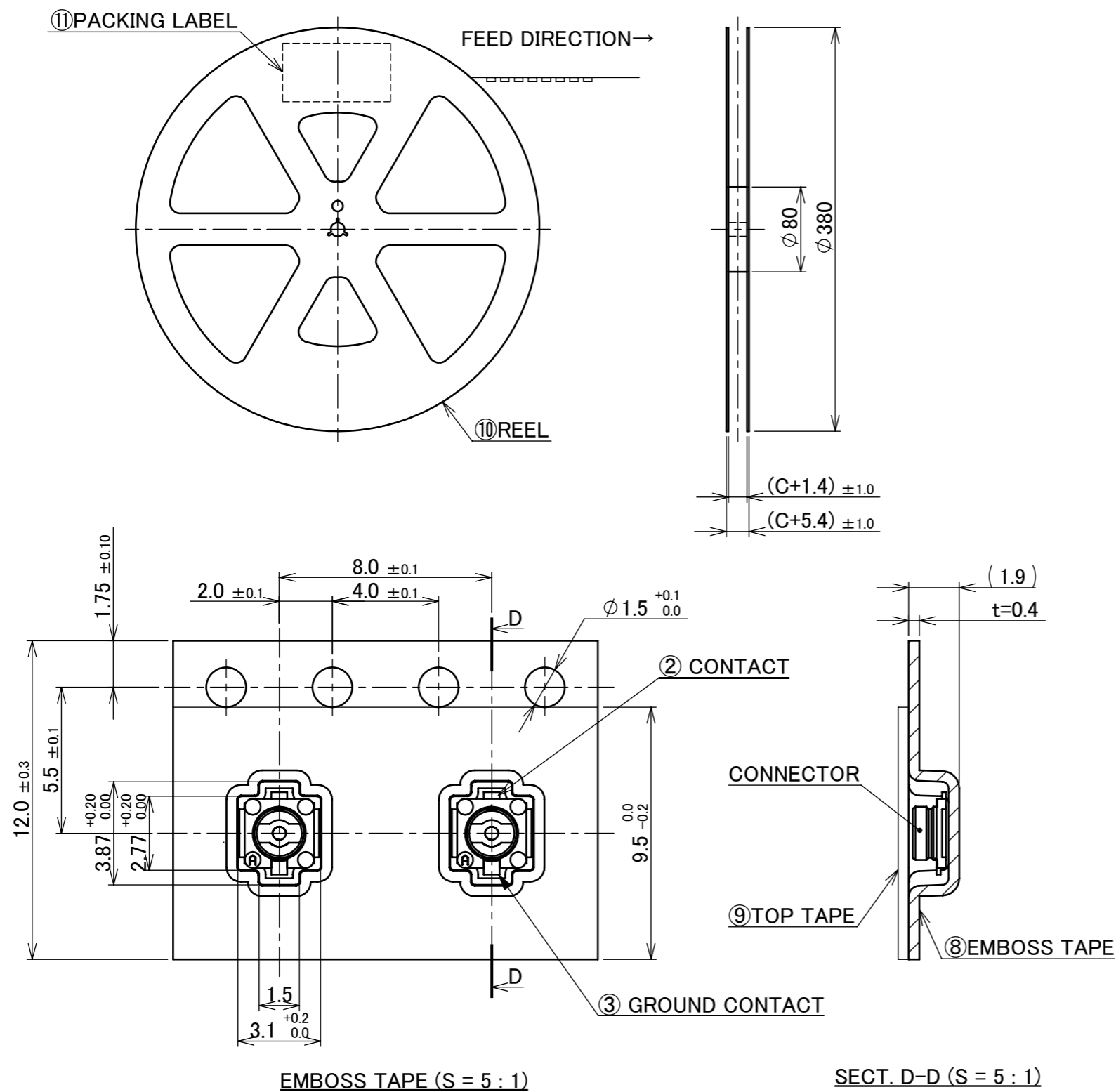

NOTES.
9. TAPING SPECIFICATION FOLLOWS JIS C 0806 (IEC 60286-3).
10. MAKE EMPTY SECTION OF LEADER AND END ON EACH END OF THE TAPE.
11. TOP TAPE SHALL NOT STICK OUT FROM EMBOSSED TAPING.
12. TOP TAPE SHALL NOT COVER FEED HOLE.

NO.	DISCRIPTION	MATERIAL	FINISH , REMARKS
11	PACKING LABEL	-	-
10	REEL	PS ESD SAFE TYPE	-
9	TOP TAPE	PET t=0.075	-
8	EMBOSS TAPE	PP t=0.4	-

ANGLE	±2°	6 OVER 30 MAX.	±0.3	PROJECTION	SERIES No.	CUSTOMER COPY		
6 MAX.	±0.2	30 OVER 120 MAX.	±0.5		R9	I-PEX		
GENERAL TOLERANCE.				TITLE	SCALE	10:1		
DWG.	DATE			MHF® I/II RECEPTACLE	UNIT	mm		
CHK.				DWG. No.	SIZE	SHEET	REV.	
APP.				20279	A3	6/8	27	

PART NO.	E	QUANTITY PER EMBOSS REEL (PIECES / REEL)	QUANTITY PER PACKING CARTON (REELS / CARTON)
20279-001E-05	12.0	10,000 / REEL	8 REELS / CARTON = 80,000 PIECES
20279-001E-06	12.0	10,000 / REEL	8 REELS / CARTON = 80,000 PIECES

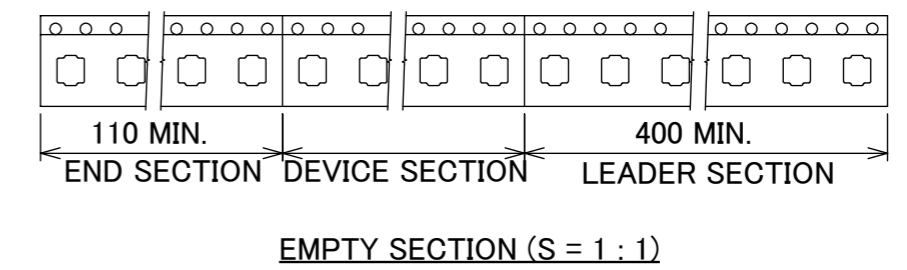
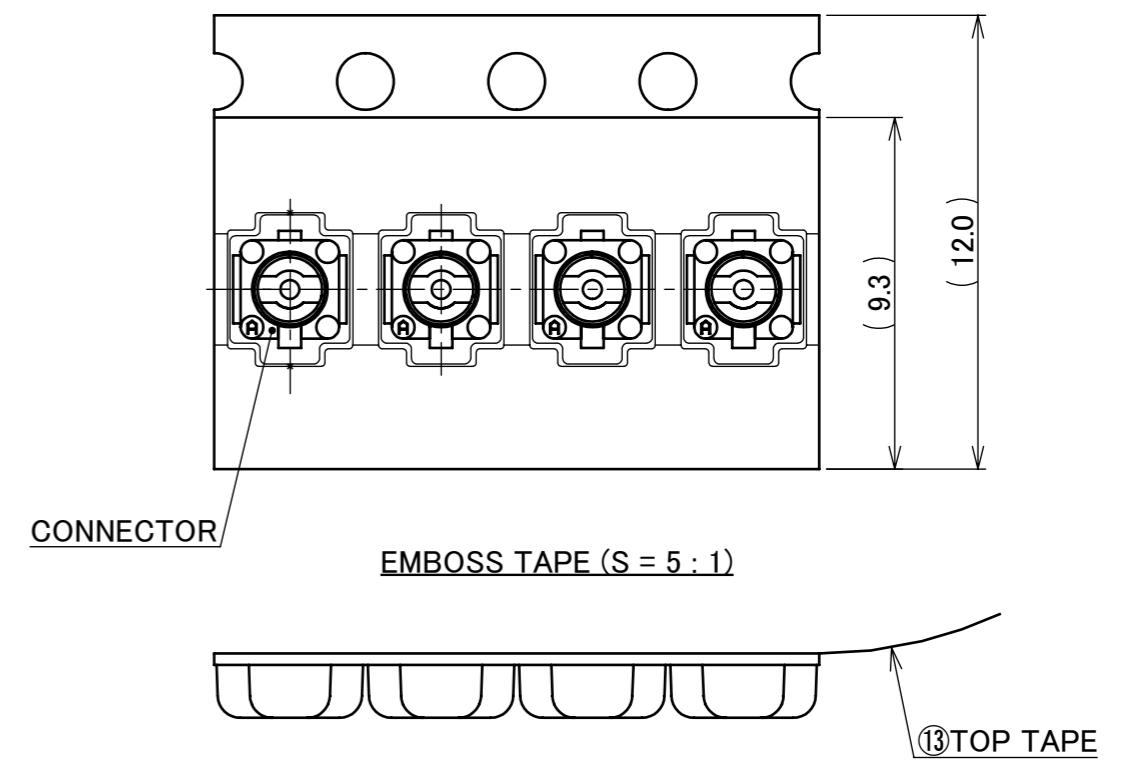
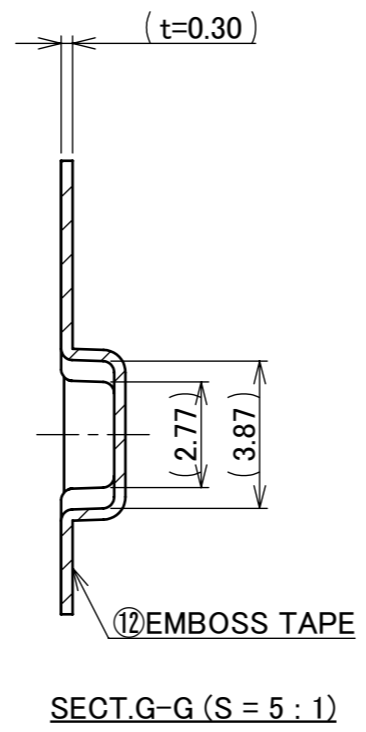
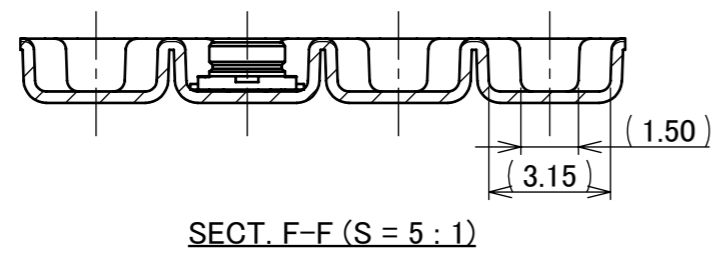
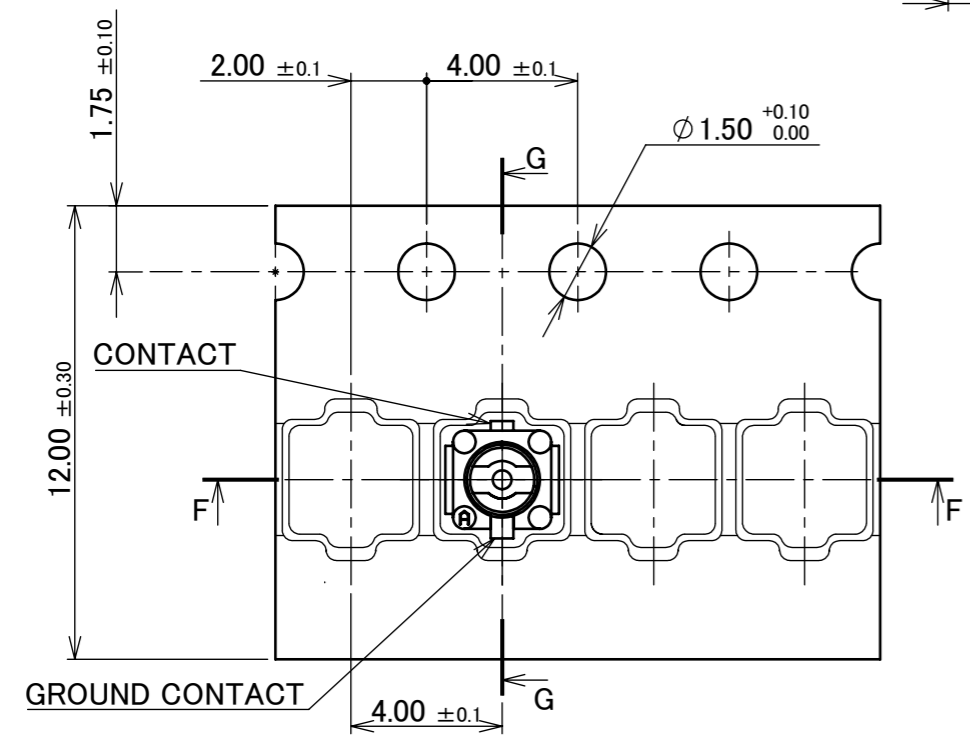
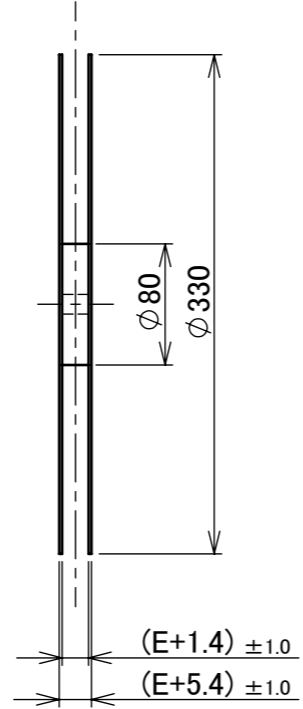
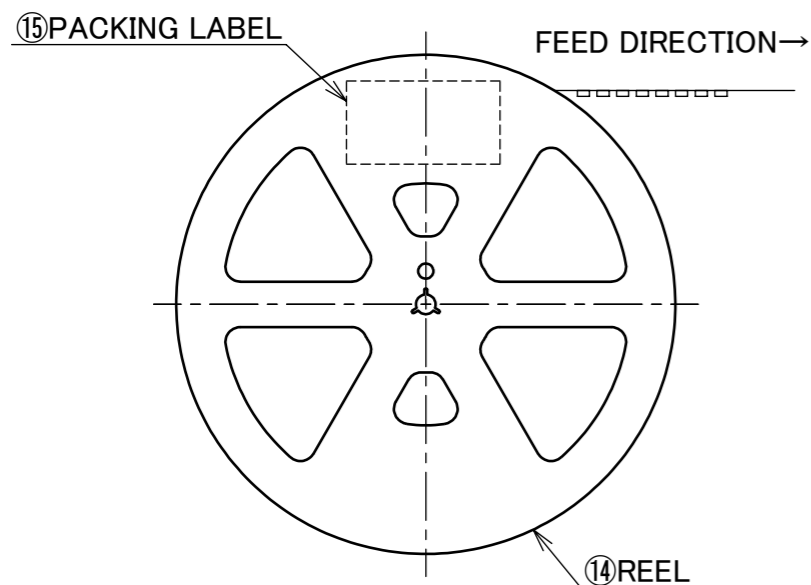

NOTES.
13. TAPING SPECIFICATION FOLLOWS JIS C 0806 (IEC 60286-3).
14. MAKE EMPTY SECTION OF LEADER AND END ON EACH END OF THE TAPE.
15. TOP TAPE SHALL NOT STICK OUT FROM EMBOSS TAPING.
16. TOP TAPE SHALL NOT COVER FEED HOLE.

NO.	DISCRIPTION	MATERIAL	FINISH , REMARKS
15	PACKING LABEL	-	-
14	REEL	PS	ANTI-STATIC TYPE
13	TOP TAPE	PET	ANTI-STATIC TYPE HEAT ACTIVATED COVER
12	EMBOSS TAPE	PS	ANTI-STATIC TYPE

ANGLE	±2°	6 OVER 30 MAX.	±0.3	PROJECTION	SERIES No.	CUSTOMER COPY				
6 MAX.	±0.2	30 OVER 120 MAX.	±0.5		R9	SCALE	I-PEX			
GENERAL TOLERANCE.						TITLE				10:1
DWG.	DATE				MHF® I/II RECEPTACLE	UNIT				
CHK.						mm				
APP.					DWG. No.	20279	SIZE	SHEET	REV.	
							A3	7/8	27	



MHF I/II SMA ADAPTOR
PART NO. 90193-002

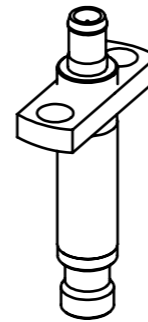

4.5MM HIGH CYCLE TEST PROBE FOR MHF/MHF A
PART NO. 90575-0001

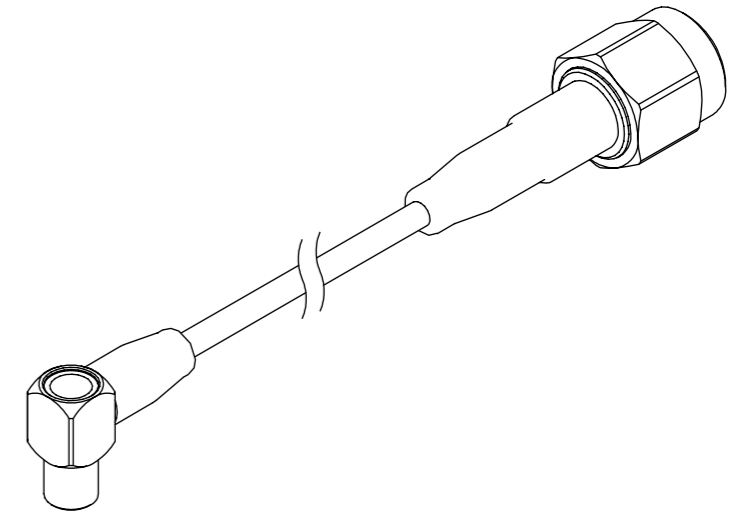

4.5MM HIGH CYCLE TEST PROBE CABLE ASS'Y
PART NO. 90577-****

* 90575-0001 AND 90577-**** SHOULD BE USED TOGETHER.

ANGLE	±2°	6 OVER 30 MAX.	±0.3	PROJECTION ⊕	SERIES No. R9	CUSTOMER COPY			
6 MAX.	±0.2	30 OVER 120 MAX.	±0.5						
GENERAL TOLERANCE.				TITLE		SCALE	I-PEX		
DWG.	DATE			MHF® I/II RECEPTACLE		2:1			
CHK.						UNIT			
APP.				DWG. No.		mm			
				20279		SIZE	SHEET	REV.	
						A3	8/8	27	