

PART NO.	L
8-25-0840	400.00±3.0 mm

PLEASE CONTACT I-PEX FOR REQUESTS OTHER THAN THIS SPECIFICATIONS.
PLEASE NOTE IF SPECIFICATIONS CHANGE, PART NO. WILL ALSO CHANGE.

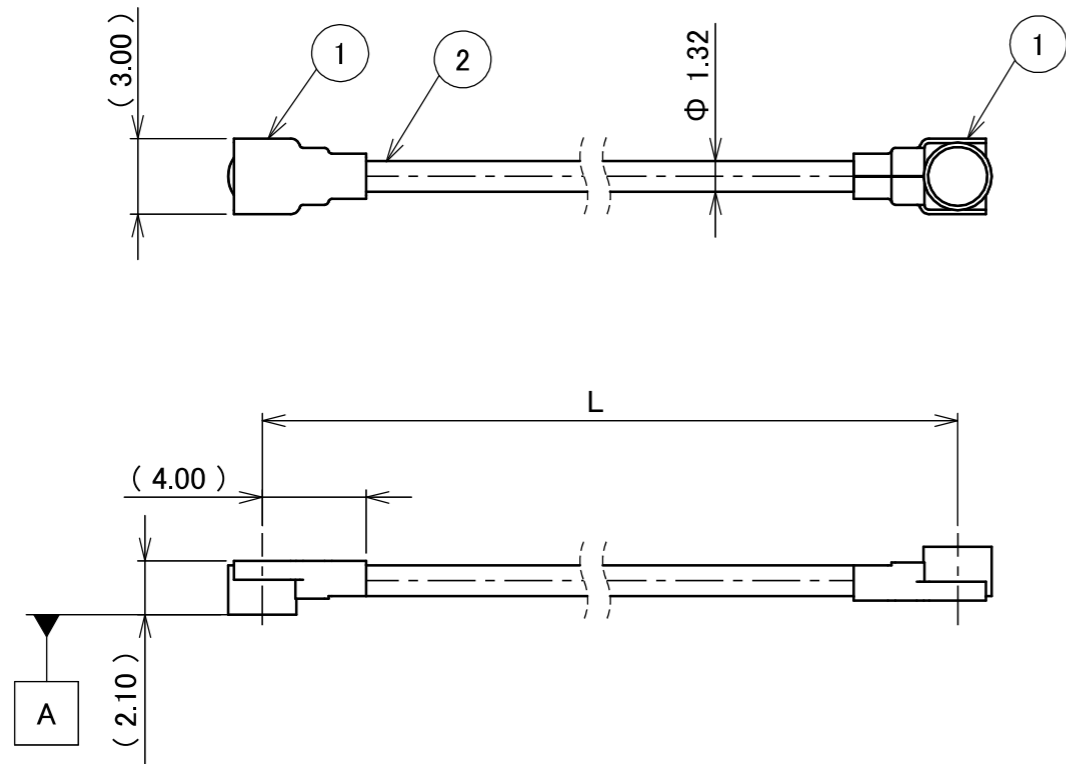

NOTES
1. SUGGESTIONS FOR MATING & UNMATING OPERATION.
1-1. MATING
MATE THE CONNECTOR VERTICALLY, ALIGNING THE MATING AXIS ON PLUG AND RECEPTACLE. DO NOT SLANT MATE.
1-2. UNMATING
1-2-1.
UNMATING BY PULLING TOOL.
[P/N 90192-001 (MHF I),]
USE THE PULLING TOOL AS THE FOLLOWING, AND PULL PLUG TO VERTICAL DIRECTION AS DIRECTLY AS POSSIBLE.

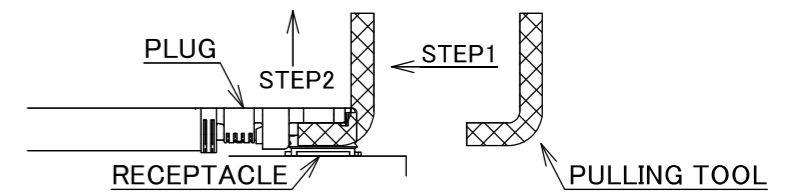

1-2-2.
UNMATING DIRECTLY BY HAND.
HOLD THE CATCHING AREA ON PLUG AND PULL THE PLUG VERTICALLY.

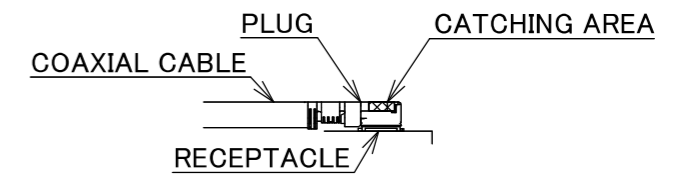

2. PACKING : PLASTIC BAG
3. PERMISSIBLE LOAD ON THE CABLE AFTER MATING

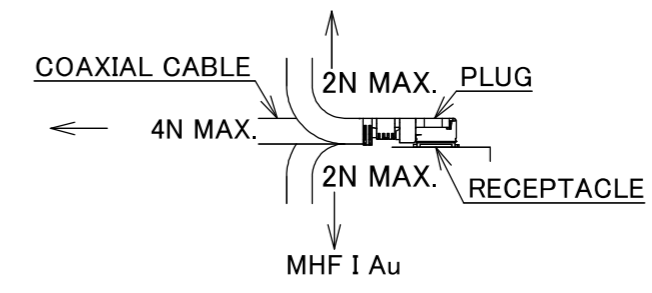

4. CABLE CRIMP STRENGTH : 10N MIN.

2	CABLE	1	AWG#32 Φ 1.32, BRAIDED SHIELD , BLACK
1	CONNECTOR-1, 2	2	MHF I Au
NO.	DESCRIPTION	QTY	REMARK

					ANGLE	±2°	6 OVER 30 MAX.	±0.3	PROJECTION	SERIES No.	CUSTOMER COPY			
					6 MAX.	±0.2	30 OVER 120 MAX.	±0.5		H-250059D	I-PEX			
					GENERAL TOLERANCE.				TITLE	SCALE	I-PEX			
					DWG.	M.Toida		DATE	2026/01/27		X:1	I-PEX		
					CHK.	T.Takuno					UNIT	I-PEX		
0	ZH00371	TOI	2026/01/27	-	APP.	K.Yufu			DWG. No.		mm	SIZE	SHEET	REV.
					REVISION RECORD				8-25-0840		A3	1/1	0	



Confidential C

I-PEX Inc.

QKE-DFE06-02 REV.12