

PART NO.	L
8-25-0932	400.00±3.0 mm

PLEASE CONTACT I-PEX FOR REQUESTS OTHER THAN THIS SPECIFICATIONS.
PLEASE NOTE IF SPECIFICATIONS CHANGE, PART NO. WILL ALSO CHANGE.

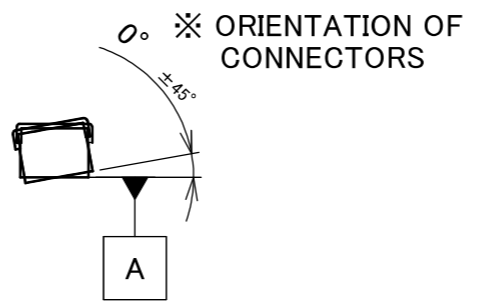

NOTES
1. SUGGESTIONS FOR MATING & UNMATING OPERATION.
1-1. MATING
MATE THE CONNECTOR VERTICALLY,
ALIGNING THE MATING AXIS ON PLUG AND RECEPTACLE.
DO NOT SLANT MATE.
1-2. UNMATING
1-2-1.
UNMATING BY PULLING TOOL.
[P/N 90612-0001 (MHF 5L),]
USE THE PULLING TOOL AS THE FOLLOWING, AND
PULL PLUG TO VERTICAL DIRECTION AS DIRECTLY AS POSSIBLE.

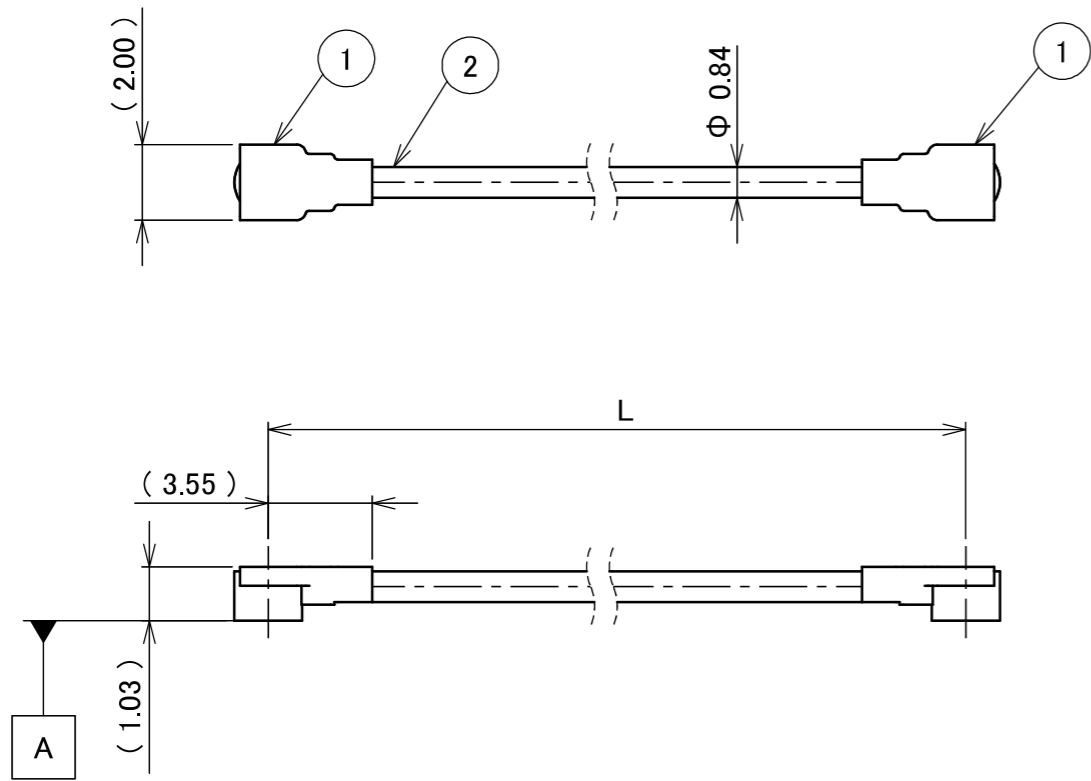
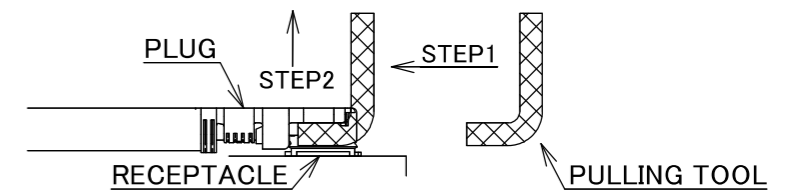

1-2-2.
UNMATING DIRECTLY BY HAND.
HOLD THE CATCHING AREA ON PLUG AND PULL THE PLUG
VERTICALLY.

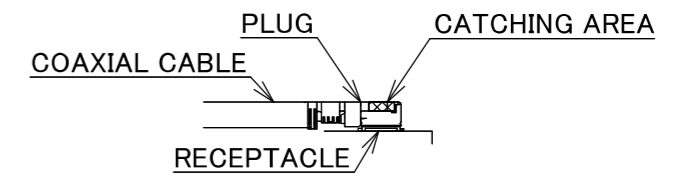

- 2. PACKING : PLASTIC BAG
- 3. PERMISSIBLE LOAD ON THE CABLE AFTER MATING

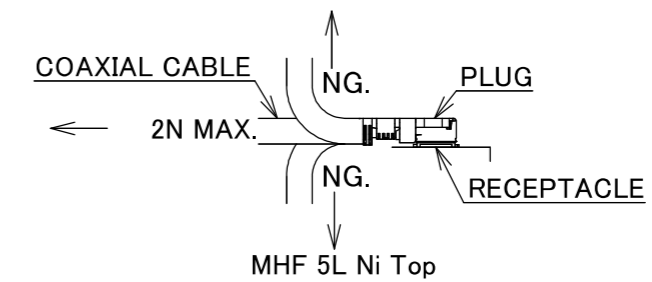

4. CABLE CRIMP STRENGTH : 10N MIN.

2	CABLE	1	AWG#33 Φ 0.84, SPIRAL SHIELD , BLACK
1	CONNECTOR-1, 2	2	MHF 5L Ni Top
NO.	DESCRIPTION	QTY	REMARK

					ANGLE	±2°	6 OVER 30 MAX.	±0.3	PROJECTION ⊕	SERIES No. H-250085D	CUSTOMER COPY				
						6 MAX.	±0.2	30 OVER 120 MAX.					±0.5		
					GENERAL TOLERANCE.				TITLE		SCALE	I-PEX			
					DWG.	M.Toida			DATE		2026/01/09		X:1		
1	ZH00619	TOI	2026/07/03	Yufu	CHK.				T.Takuno		UNIT		mm		
0	ZH00311	TOI	2026/01/09	-	APP.				K.Yufu		SIZE	A3			
REV.	ECN	BY	DATE	APP.	REVISION RECORD				DWG. No.		8-25-0932		SHEET	1/1	REV.

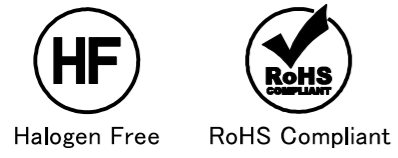

Confidential C

I-PEX Inc.

QKE-DFE06-02 REV.12