

PART NO.  
20981-001E-02

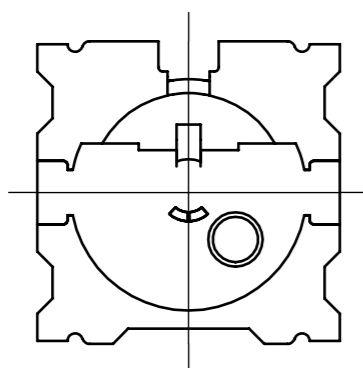

NOTES

1. APPLICABLE CONNECTOR  
20980-001R-13
2. COPLANARITY: 0.08mm MAX.
3. CHARACTERISTIC IMPEDANCE: 50 Ω (NOMINAL VALUE)

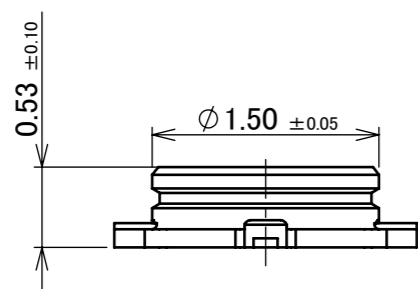
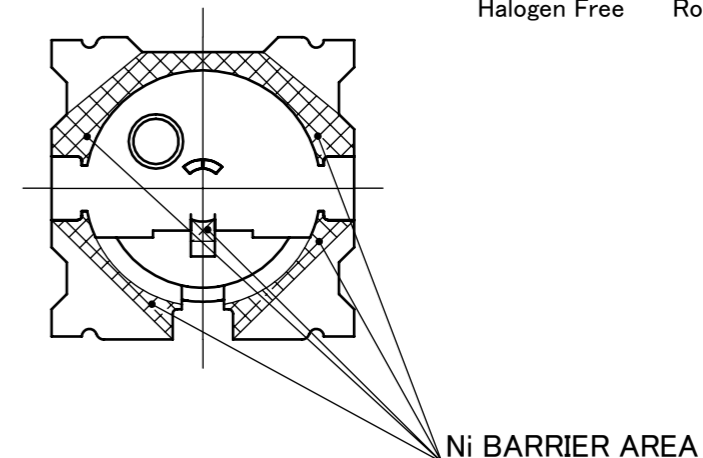
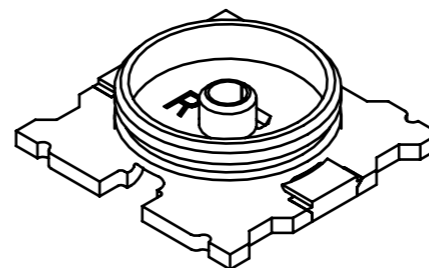
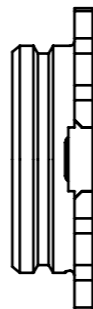
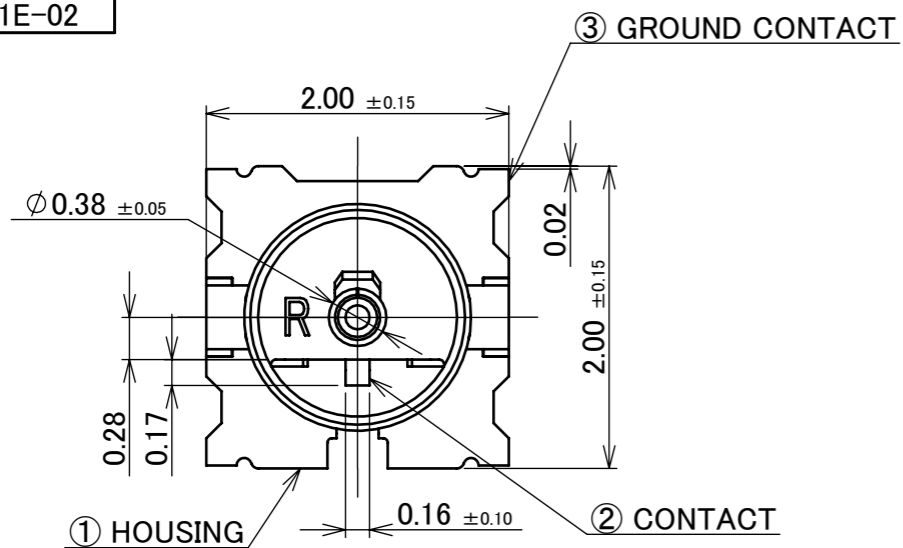
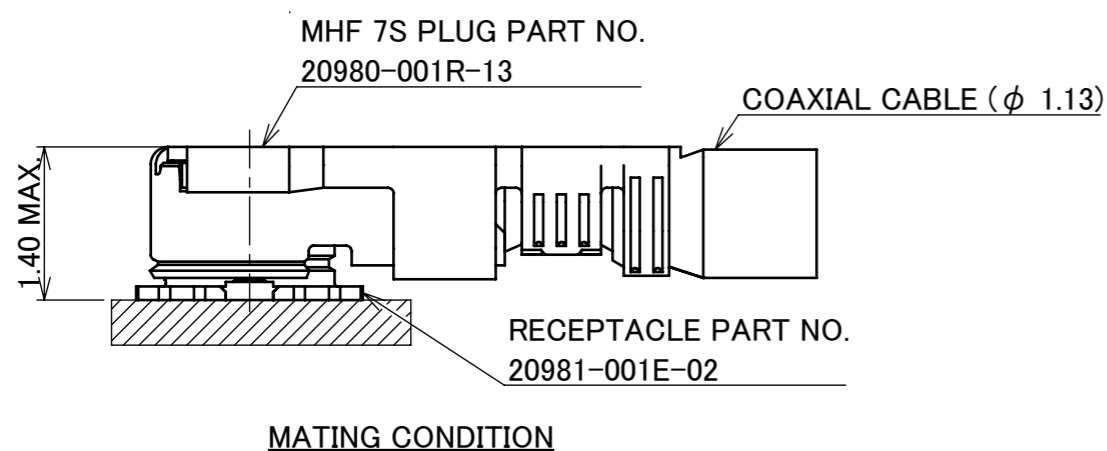

NO.	DESCRIPTION	MATERIAL	FINISH , REMARKS
3	GROUND CONTACT	PHOSPHOR BRONZE	ALL OVER: Ni 1.00 μm MIN. CONTACT PART: 0.05 μm MIN. SOLDERING PART Au AREA: 0.02 μm MIN.
2	CONTACT	CORSON ALLOY	ALL OVER: Ni 1.00 μm MIN. CONTACT PART: 0.1 μm MIN. SOLDERING PART Au AREA: 0.02 μm MIN.
1	HOUSING	LCP	UL94V-0, WHITE

REV.	ECN	BY	DATE	APP.	APP.	ANGLE	±2°	6 OVER 30 MAX.	±0.3	PROJECTION	SERIES No.	CUSTOMER COPY		
5	Z230562	Y.I	2023/05/18	Y.H	ANGLE	±2°	6 OVER 30 MAX.	±0.3			R4	CUSTOMER COPY		
4	Z201306	Y.I	2020/12/23	Hiro	6 MAX.	±0.2	30 OVER 120 MAX.	±0.5						
3	Z201255	Y.I	2020/12/11	Hiro	GENERAL TOLERANCE.				TITLE		SCALE			
2	Z201164	Y.I	2020/11/09	Hiro	DWG.	Y.Imaji	DATE	2020/07/13	MHF® 7S RECEPTACLE		20:1	I-PEX		
1	Z201053	Y.I	2020/10/12	Hiro	CHK.	S.Suzuki					UNIT			
0	Z200670	Y.I	2020/07/13		APP.	Hiro Takahashi					mm			
REV.	ECN	BY	DATE	APP.	APP.	REVISION RECORD		Hiro Takahashi		DWG. No.	20981	SIZE	SHEET	REV.
												A3	1/5	5

ITEMS	SPECIFICATION
APPLICABLE CONNECTOR PART No.	20980-001R-13
RATING VOLTAGE	60 V AC (R.M.S)/DC
RATING FREQUENCY	DC~15 GHz
OPERATING TEMPERATURE	233~363 K (-40°C~+90°C)
OPERATING HUMIDITY	90% MAX. (NON-CONDENSING)
CHARACTERISTIC IMPEDANCE	50 ohm (NOMINAL VALUE)
VSWR	1.30 MAX. AT 0.1 ~ 3 GHz, 1.35 MAX. AT 3 ~ 6 GHz, 1.40 MAX. AT 6 ~ 9 GHz, 1.45 MAX. AT 9 ~ 12 GHz, 1.50 MAX. AT 12 ~ 15 GHz
MAIN CONTACT RESISTANCE	INITIAL : 20 mohm MAX. / AFTER TEST : $\Delta$ R 20 mohm MAX.
GROUND CONTACT RESISTANCE	INITIAL : 20 mohm MAX. / AFTER TEST : $\Delta$ R 20 mohm MAX.
INSULATION RESISTANCE	INITIAL : 500 Mohm MIN. / AFTER TEST : 100 Mohm MIN.
DIELECTRIC WITHSTANDING VOLTAGE	AC200V 1min
DURABILITY	30 CYCLES
MATING FORCE (INITIAL / AFTER TEST)	INITIAL: 30N MAX. (VERTICAL DIRECTION) AFTER TEST: 30N MAX. (VERTICAL DIRECTION)
UNMATING FORCE (INITIAL / AFTER TEST)	INITIAL: 20N MAX., 5N MIN. (VERTICAL DIRECTION) AFTER TEST: 20N MAX., 3N MIN. (VERTICAL DIRECTION)
CRIMP STRENGTH	10N MIN.
PRODUCT SPECIFICATION	PRS-2676
TEST REPORT	TR-20043
PACKING STANDARD	PST-19094
INSTRUCTION MANUAL	HIM-19009
APPEARANCE CRITERIA No.	QLS-A***

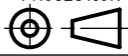
ANGLE	$\pm 2^\circ$	6 OVER 30 MAX.	$\pm 0.3$	PROJECTION 	SERIES No. R4	CUSTOMER COPY		
6 MAX.	$\pm 0.2$	30 OVER 120 MAX.	$\pm 0.5$					
GENERAL TOLERANCE.				TITLE MHF <sup>®</sup> 7S RECEPTACLE	SCALE -	<b>I-PEX</b>		
DWG.	DATE							
CHK.								
APP.								
				DWG. No.	20981	SIZE A3	SHEET 2/5	REV. 5

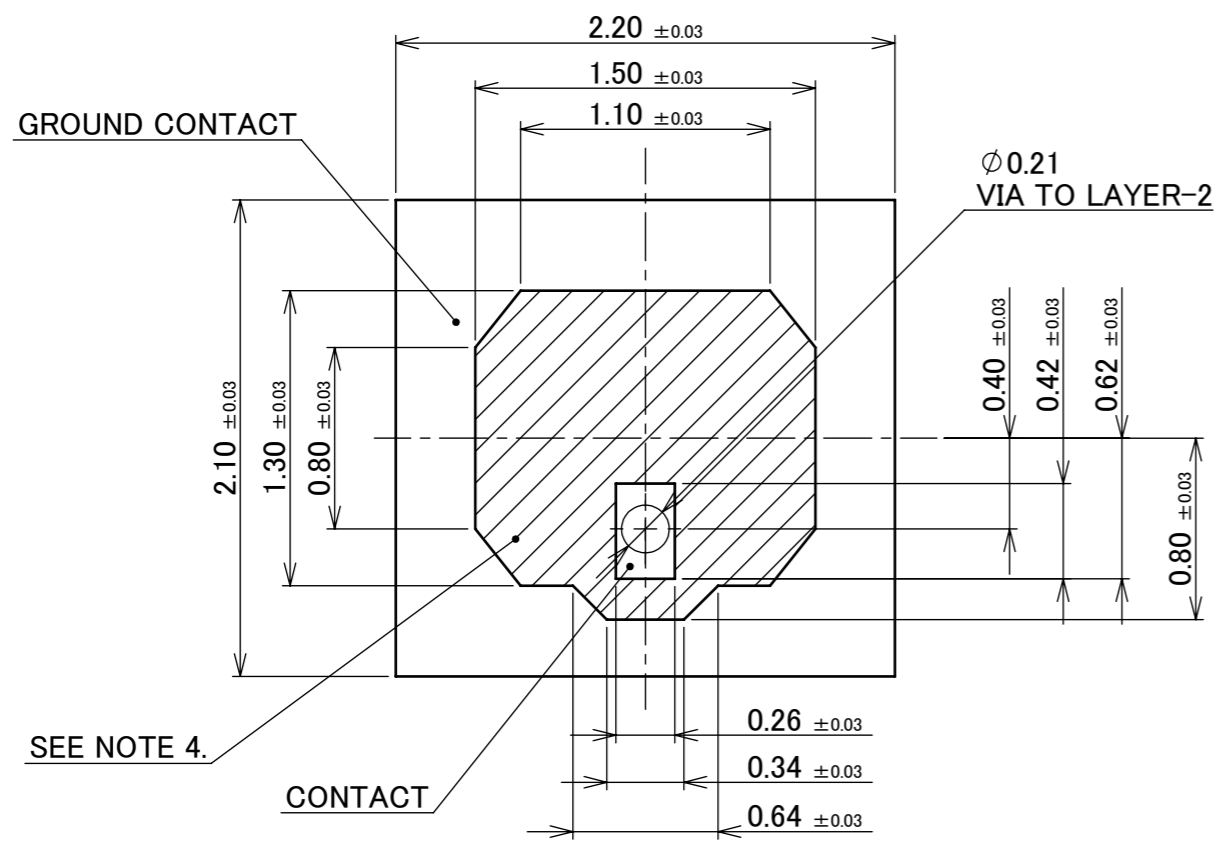

RECOMMENDED FOOTPRINT PATTERN

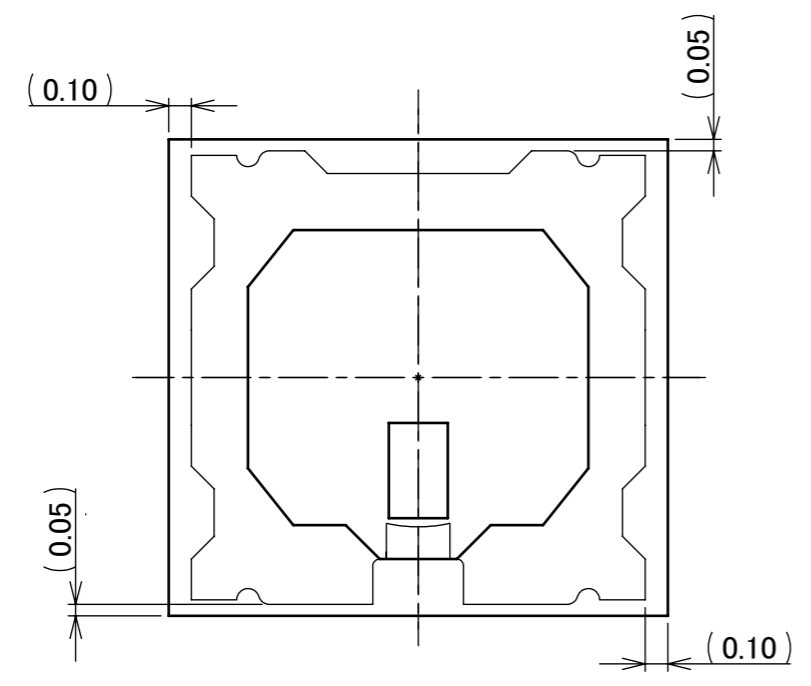

CONNECTOR ON RECOMMENDED FOOTPRINT PATTERN

NOTES.  
4. NO GROUND, SIGNAL, AND RESIST IN THIS AREA.

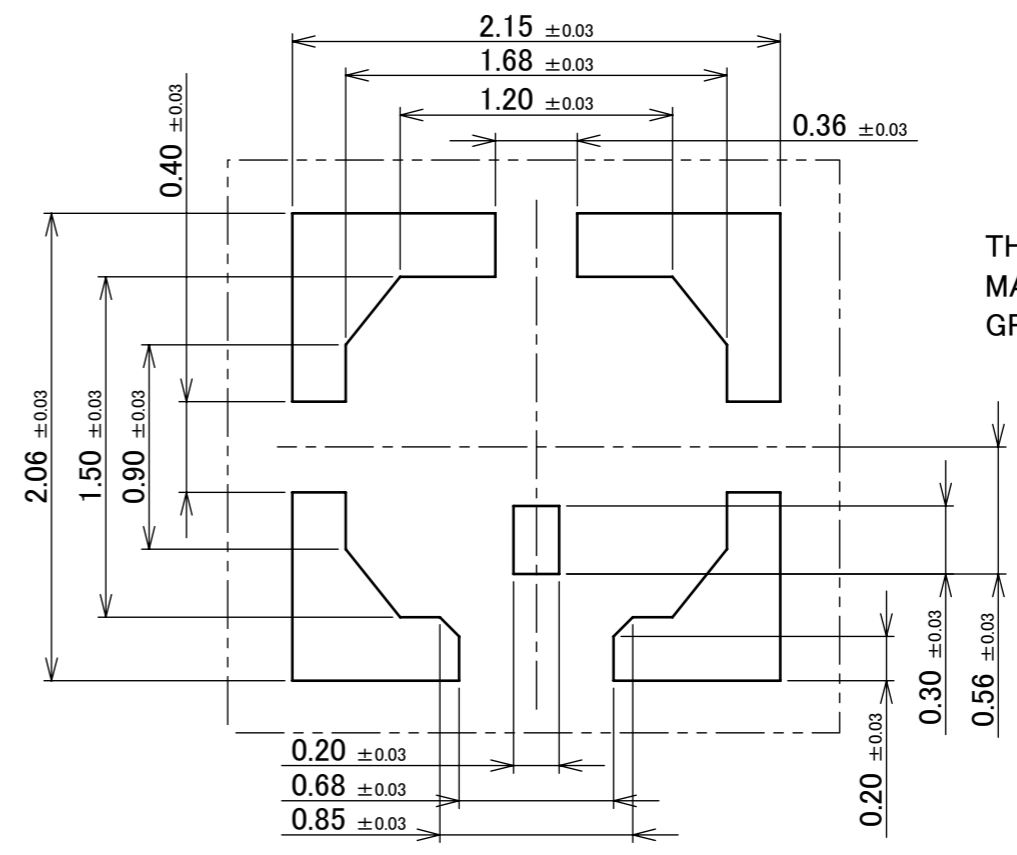

METAL MASK

THICKNESS: 0.08  
MAIN CONTACT: 55%  
GROUND CONTACT: 60%

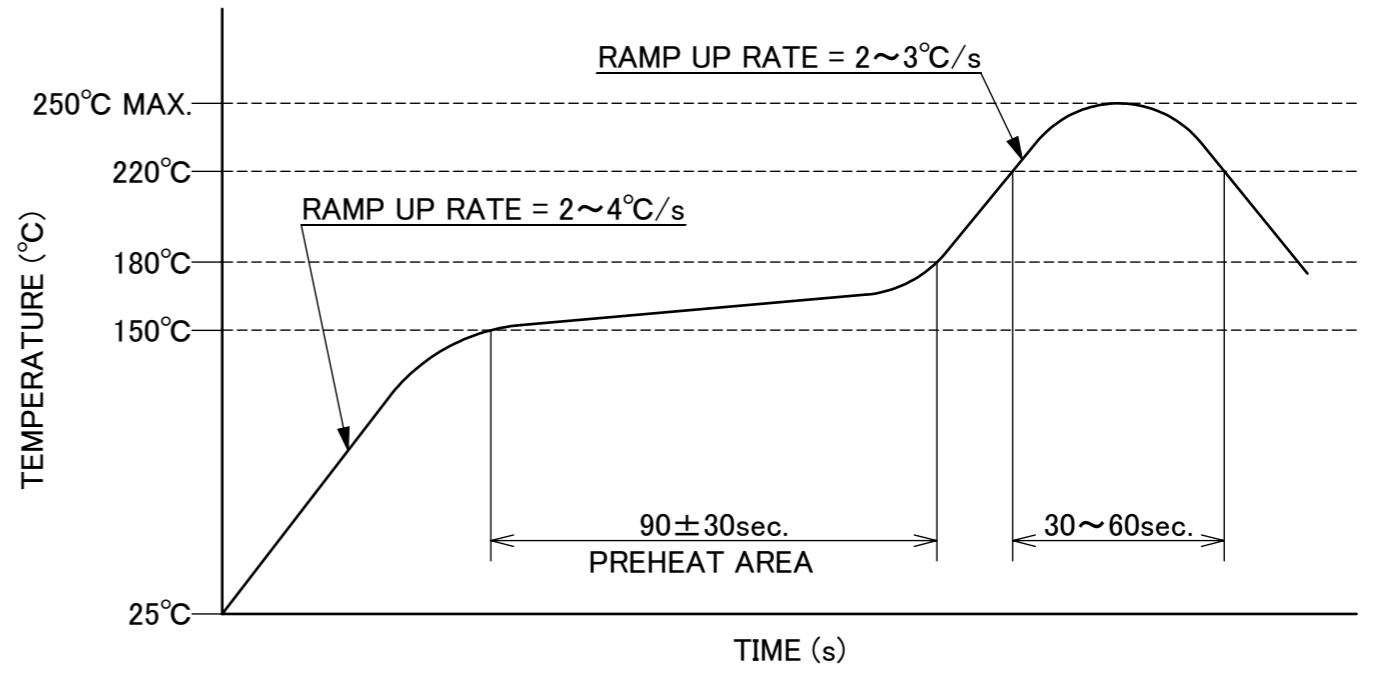

REFLOW TEMPERATURE PROFILE  
SENJU METAL INDUSTRY CO., LTD. : M705-SHF(Sn96.5 Ag3.0 Cu0.5)

ANGLE	±2°	6 OVER 30 MAX.	±0.3	PROJECTION ⊕	SERIES No. R4	CUSTOMER COPY			
	6 MAX.	±0.2	30 OVER 120 MAX.						±0.5
GENERAL TOLERANCE.				TITLE		SCALE	<b>I-PEX</b>		
DWG.	DATE			MHF® 7S RECEPTACLE		30:1			
CHK.						UNIT			
APP.				DWG. No. 20981		mm			
						SIZE	SHEET	REV.	
						A3	3/5	5	

PART NO.	G	QTY. PER EMBOSS REEL (PIECES / REEL)	QTY. PER PACKING CARTON (REELS / CARTON)
20981-001E-02	12	10,000 / REEL	9 / CARTON = 90,000 PIECES

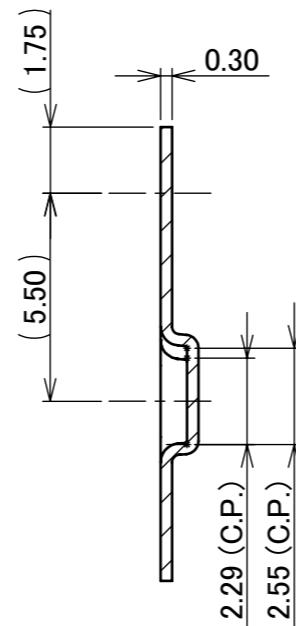
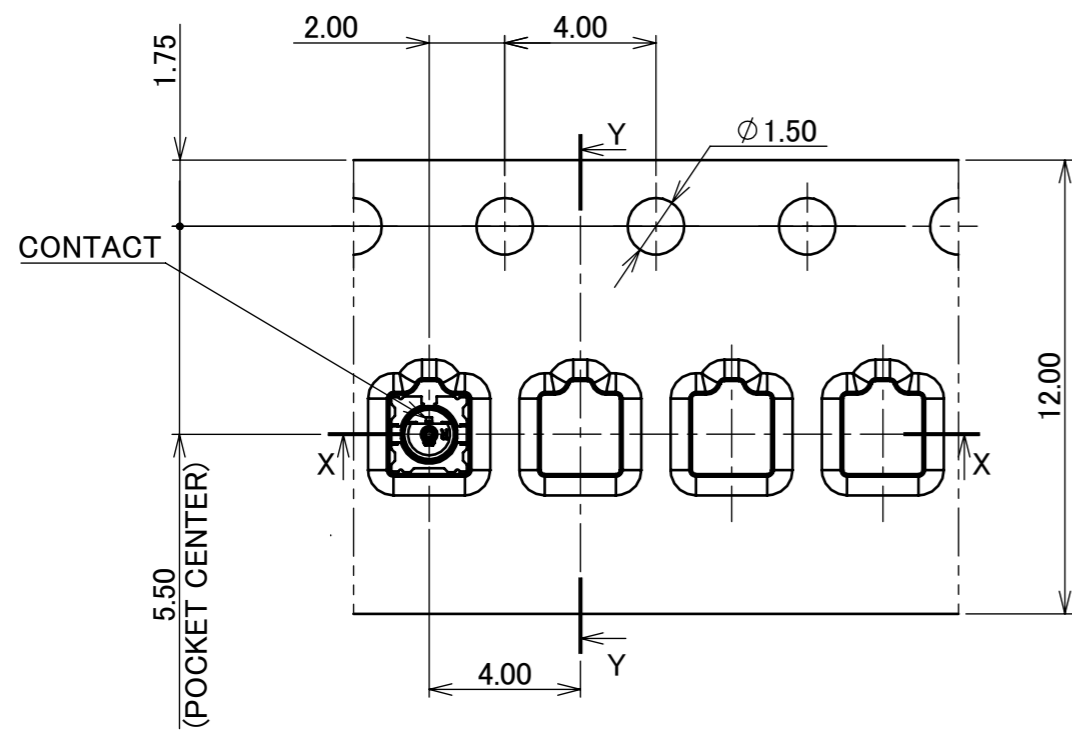
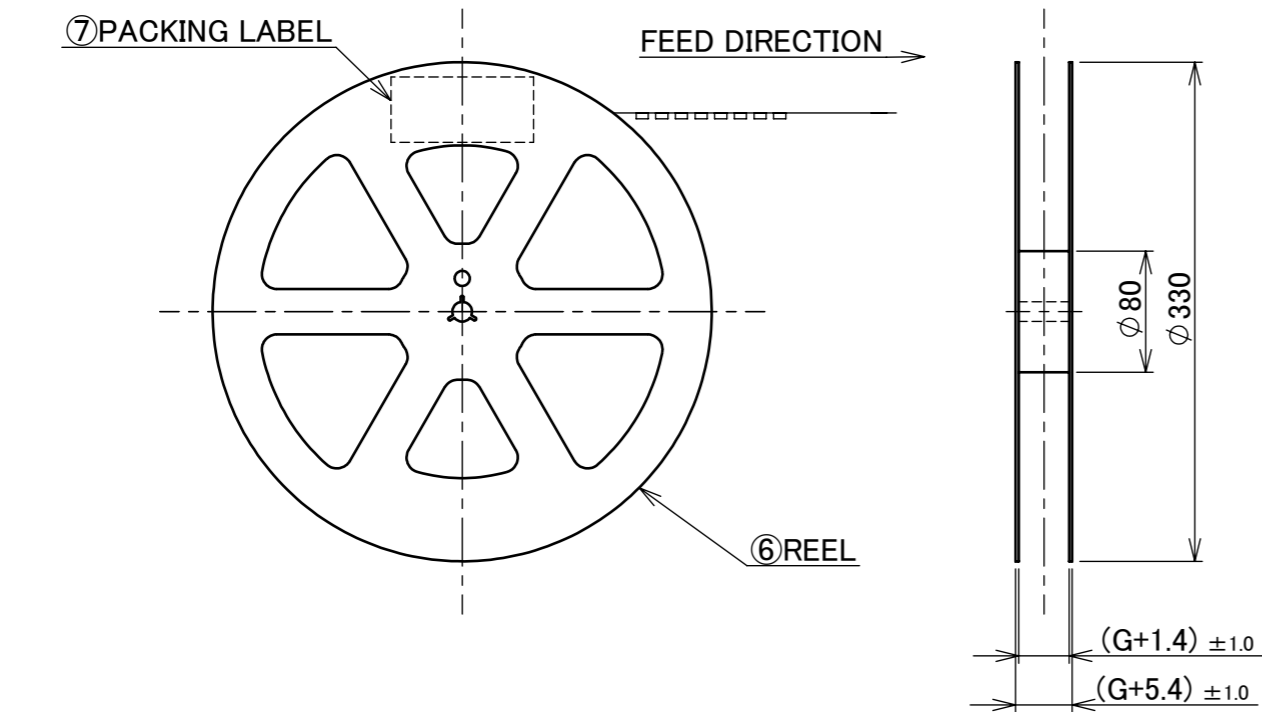

SECT. Y-Y

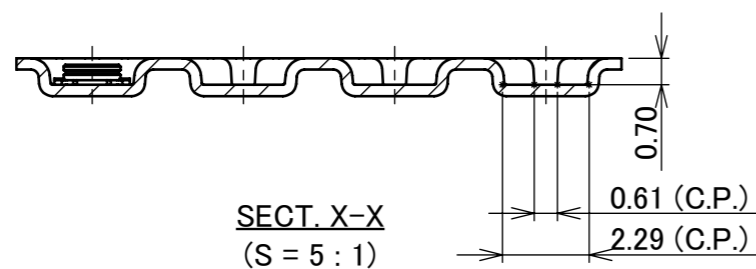

SECT. X-X  
(S = 5 : 1)

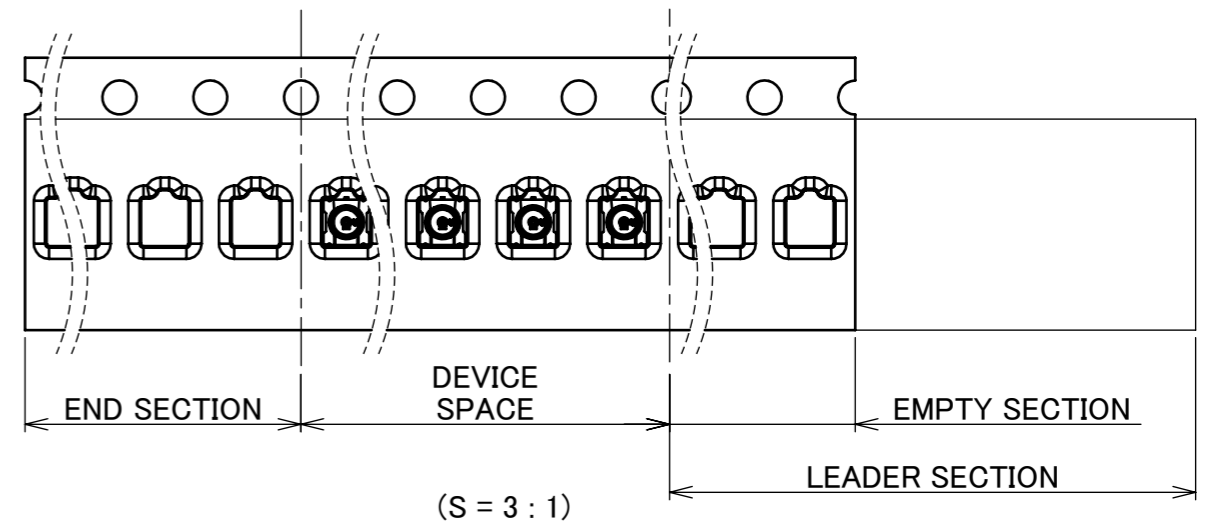
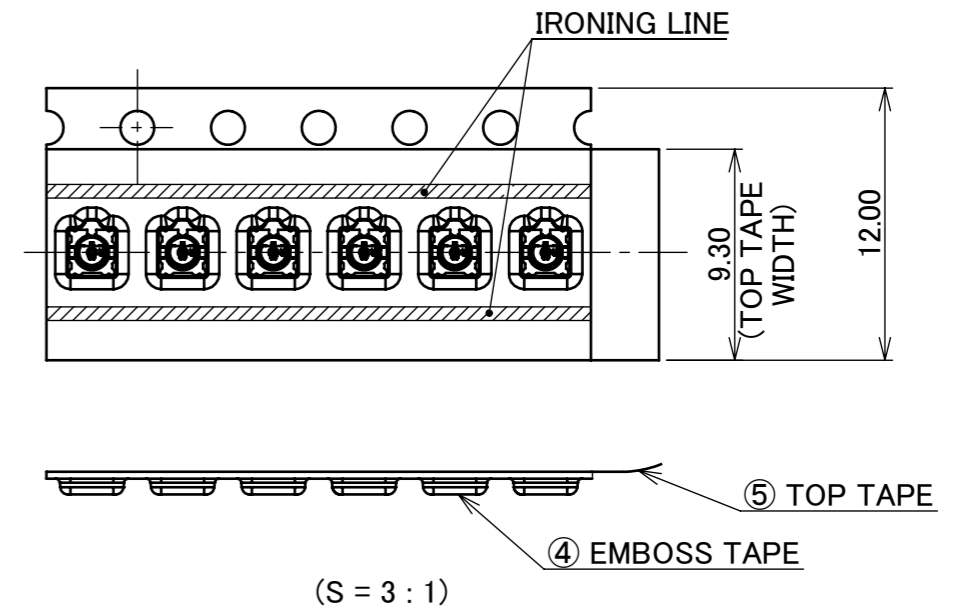

NOTES.

- TAPING SPECIFICATION FOLLOWS JIS C 0806 (IEC 60286-3).
- MAKE EMPTY SECTION OF LEADER AND END ON EACH END OF THE TAPE.
- TOP TAPE SHALL NOT STICK OUT FROM EMBOSS TAPE.
- TOP TAPE SHALL NOT COVER FEED HOLE.

NO.	DESCRIPTION	MATERIAL	FINISH, REMARKS
7	PACKING LABEL	-	-
6	REEL	PS	ANTI-STATIC TYPE
5	TOP TAPE	PET t=0.062	ANTI-STATIC TYPE
4	EMBOSS TAPE	PS t=0.3	-

ANGLE	±2°	6 OVER 30 MAX.	±0.3	PROJECTION ⊕	SERIES No. R4	CUSTOMER COPY			
6 MAX.	±0.2	30 OVER 120 MAX.	±0.5						
GENERAL TOLERANCE.				TITLE MHF® 7S RECEPTACLE	SCALE X:1	I-PEX			
DWG.	DATE								UNIT mm
CHK.									SIZE A3
APP.									SHEET 4/5
				DWG. No.	20981				

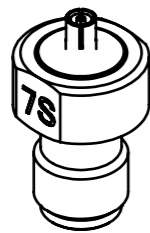

MHF 7S RECEPTACLE SMA ADAPTER  
PART NO. 91256-0001

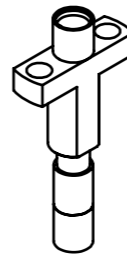

MHF 7S RECEPTACLE HIGH CYCLE N30 SMPM ADAPTER  
PART NO. 91145-0001

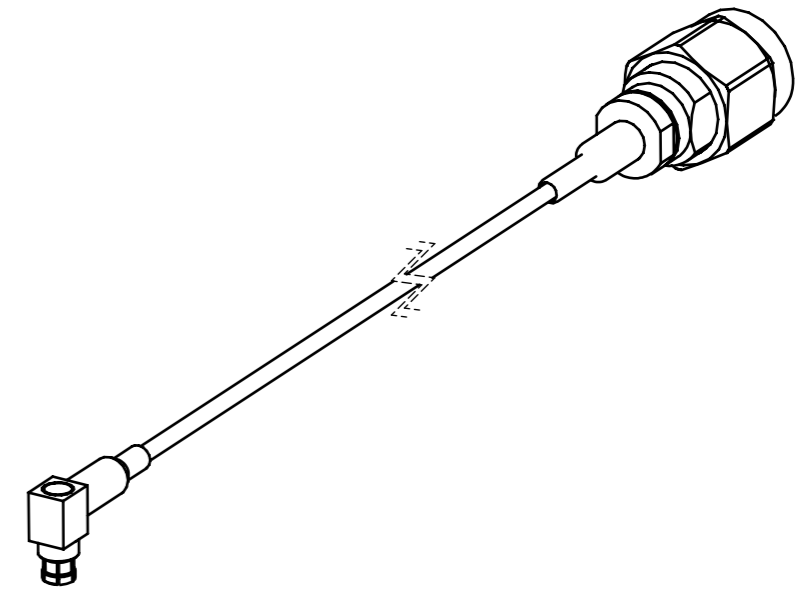

MHF SERIES N30 SMPM TO SMA ADAPTER CABLE  
PART NO. 91197-300\*

\* 91145-0001 AND 91197-300\* SHOULD BE USED TOGETHER.

ANGLE	±2°	6 OVER 30 MAX.	±0.3	PROJECTION ⊕	SERIES No. R4	CUSTOMER COPY		
6 MAX.	±0.2	30 OVER 120 MAX.	±0.5					
GENERAL TOLERANCE.				TITLE MHF® 7S RECEPTACLE	SCALE 2:1	UNIT <b>I-PEX</b>		
DWG.	DATE							
CHK.								
APP.								
				DWG. No.	20981	SIZE A3	SHEET 5/5	REV. 5