

PART No.

90698-0001



Halogen Free



RoHS Compliant

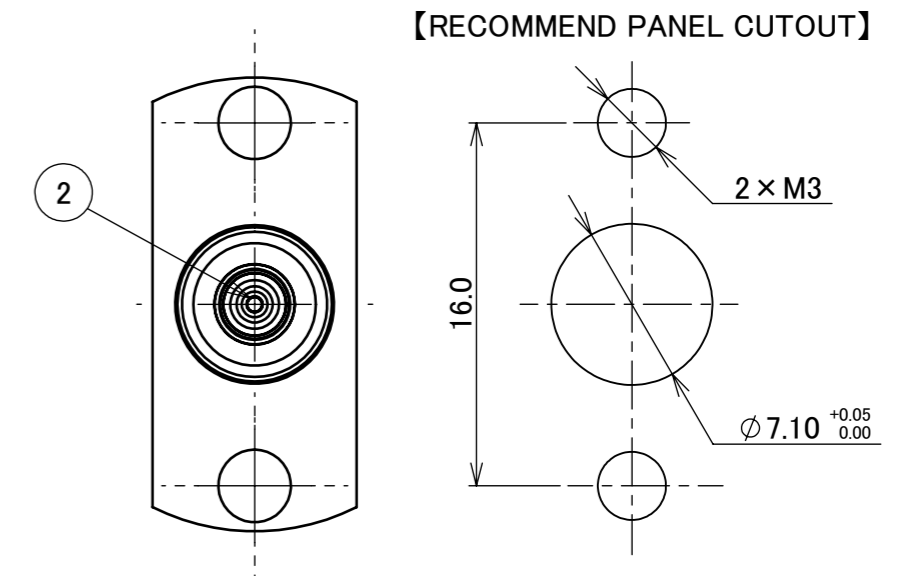
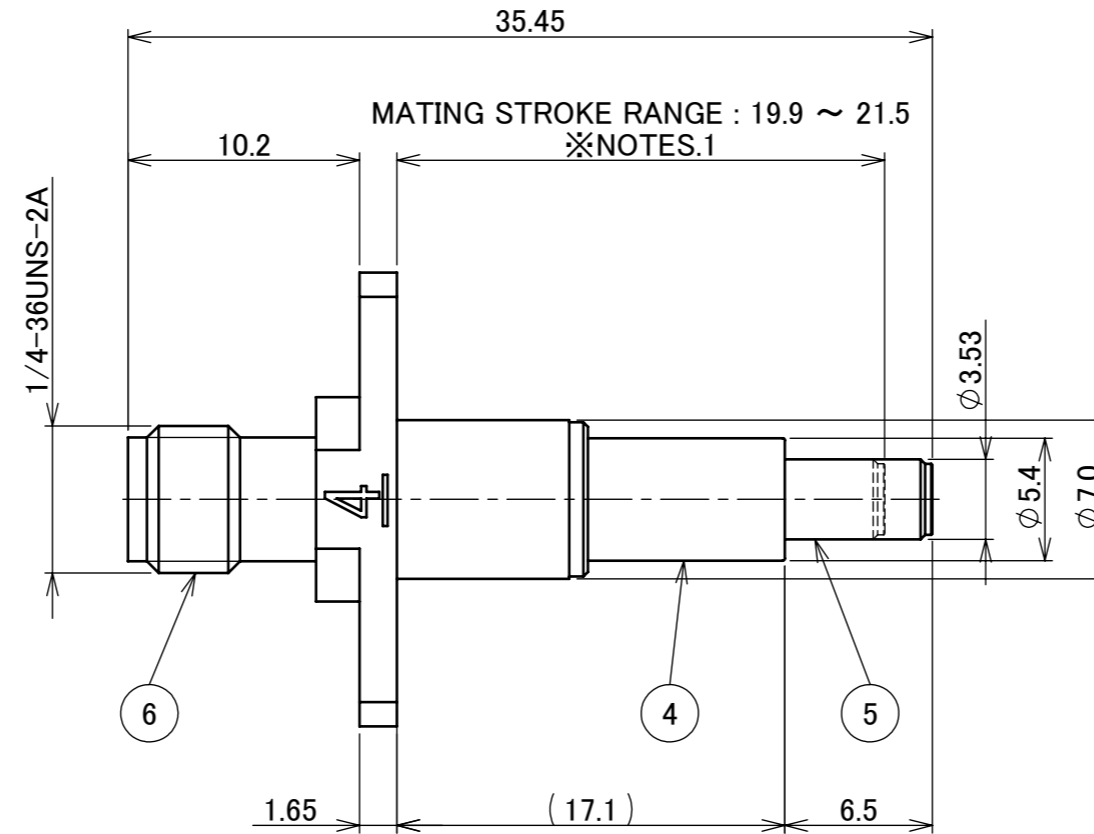
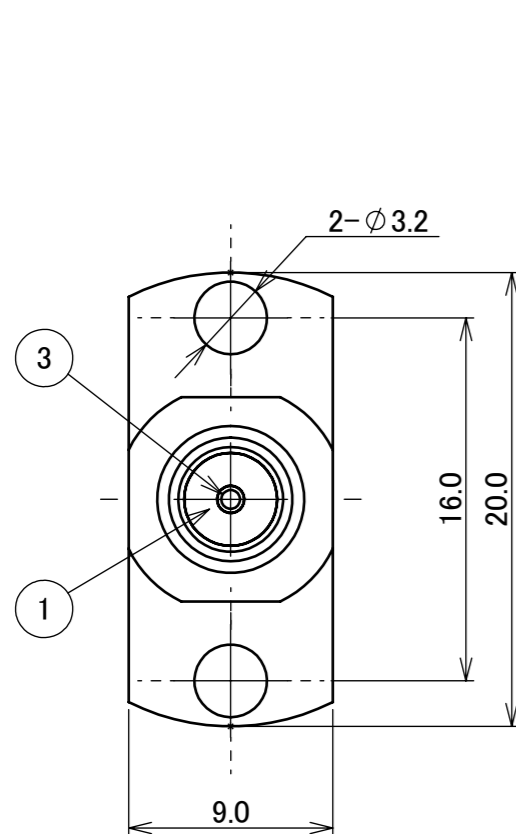
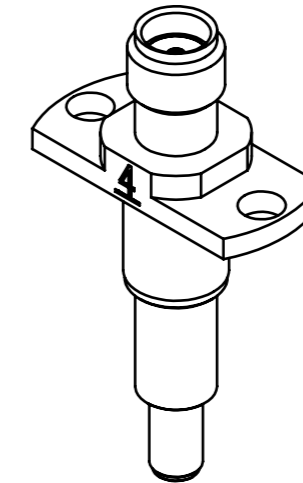

NOTES.

1. WHEN MATING ADAPTER TO CONNECTOR, MATING STROKE LENGTH NEEDS TO BE IN RANGE OF 21.5 mm TO 19.9 mm FROM EDGE OF FLANGE (EDGE CLOSER TO TIP OF PROBE) TO TIP OF PROBE.
2. AXIAL MISALIGNMENT DISTANCE: 0.25 mm MAX.

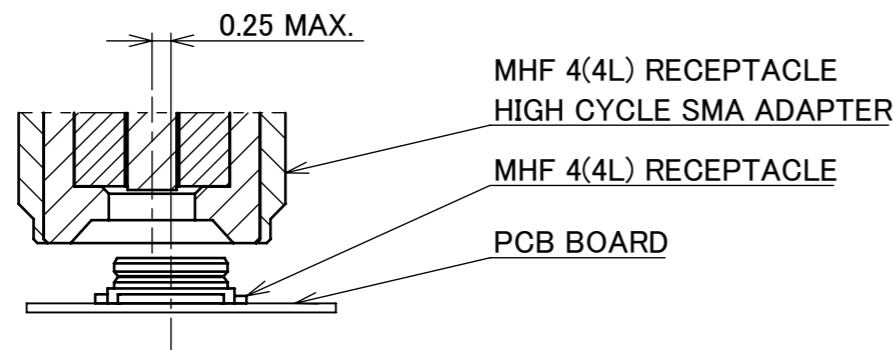

NO.	DESCRIPTION	MATERIAL	FINISH , REMARKS
6	SHELL	STAINLESS STEEL	PASSIVATION
5	OUTER CONTACT B	STAINLESS STEEL	Au 1.0 μm MIN. OVER Ni 1.0 μm MIN.
4	OUTER CONTACT A	STAINLESS STEEL	PASSIVATION
3	PIN CONTACT B	BERYLLIUM COPPER	Au 1.0 μm MIN. OVER Ni 1.0 μm MIN.
2	PIN CONTACT A	BERYLLIUM COPPER	Au 1.0 μm MIN. OVER Ni 1.0 μm MIN.
1	INSULATOR	PTFE	

NO.	DESCRIPTION	MATERIAL	FINISH , REMARKS													
6	Z220687	Y.I	2022/06/17	Y.H	ANGLE	±2°	6 OVER 30 MAX.	±0.3	PROJECTION ⊕	SERIES No. R0	CUSTOMER COPY					
5	Z190626	K.I	2019/05/08	Y.H	6 MAX.	±0.2	30 OVER 120 MAX.	±0.5								
4	Z190239	K.M	2019/02/22	Y.H	GENERAL TOLERANCE.			TITLE MHF® 4(4L) RECEPTACLE HIGH CYCLE SMA ADAPTER	SCALE 3:1	UNIT mm	I-PEX					
3	Z180348	Y.I	2018/03/16	Ken	DWG.	S.Hamada	DATE					2014/04/08				
2	Z171198	Y.I	2017/10/17	Ken	CHK.	K.Yotsutani										
1	Z150461	S.H	2015/05/01	Tom	APP.	T.Takano			DWG. No.	90698	SIZE	A3	SHEET	1/2	REV.	6

ITEMS	SPECIFICATION
RECOMMENDED APPLICABLE CONNECTOR PART No.	MHF 4 RECEPTACLE P/N: 20449-001E-** MHF 4L RECEPTACLE P/N: 20579-001E-**
RATING FREQUENCY	DC~12 GHz
OPERATING TEMPERATURE	243~343 K (-30°C~+70°C)
VSWR (MATED WITH 90449-0001)	1.30 MAX. AT 0.1~3GHz, 1.50 MAX. AT 3~6GHz, 1.65 MAX. AT 6~9GHz, 2.00 MAX. AT 9~12GHz
INSERTION LOSS	-0.8dB MIN. (DC~6GHz), -1.0dB MIN. (6~12GHz)
INSULATION RESISTANCE	500 Mohm MIN.
DIELECTRIC WITHSTANDING VOLTAGE	AC 300V 1min
DURABILITY	10.000CYCLES
PRODUCT SPECIFICATION	PRS-2085
TEST REPORT	TR-15037
INSTRUCTION MANUAL	HIM-22010
APPEARANCE CRITERIA No.	QLS-A***

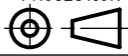
ANGLE	±2°	6 OVER 30 MAX.	±0.3	PROJECTION 	SERIES No. R0	CUSTOMER COPY		
6 MAX.	±0.2	30 OVER 120 MAX.	±0.5					
GENERAL TOLERANCE.				TITLE MHF® 4(4L) RECEPTACLE HIGH CYCLE SMA ADAPTER	SCALE -	I-PEX		
DWG.	DATE							
CHK.								
APP.								
				DWG. No.	90698	SIZE A3	SHEET 2/2	REV. 6