

Recommended P/N 20579-001E

PART NO.	PACKING QUANTITY / REEL
20579-001E	10,000 PCS.
20579-001E-01	20,000 PCS.



Halogen Free



RoHS Compliant

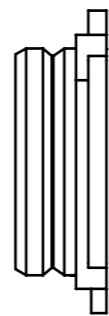
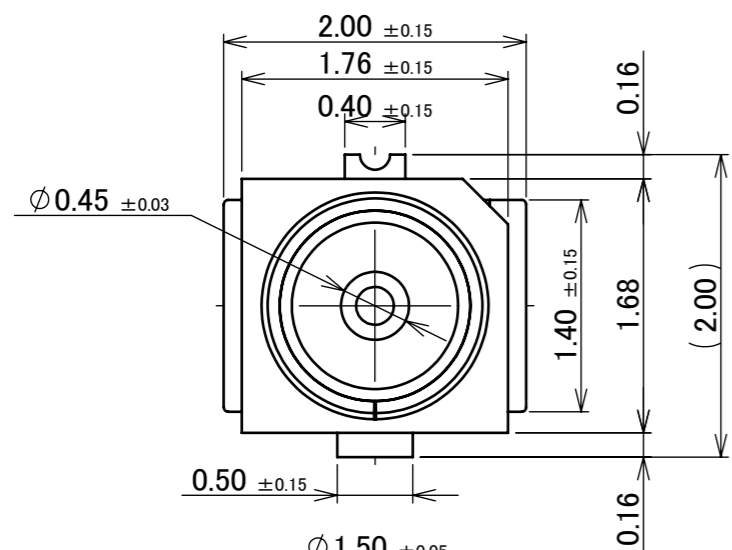

SMT Au PLATING AREA (GROUND CONTACT)

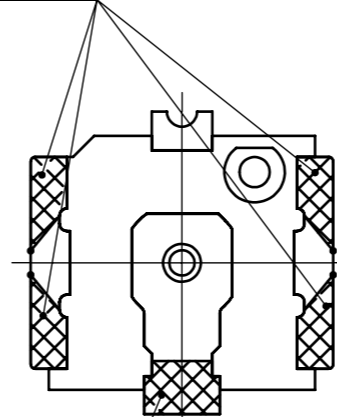

SMT Au PLATING AREA (CONTACT)

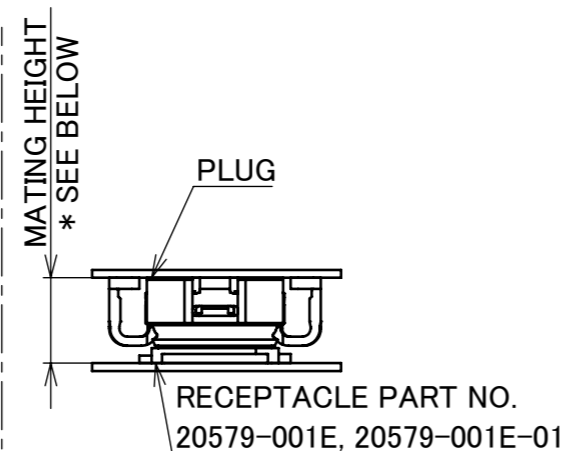
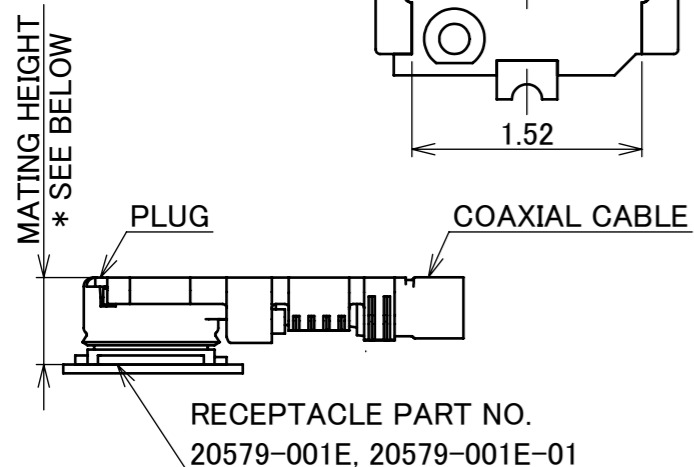
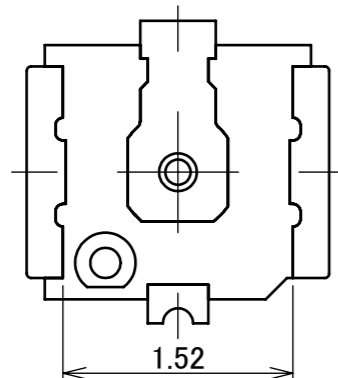
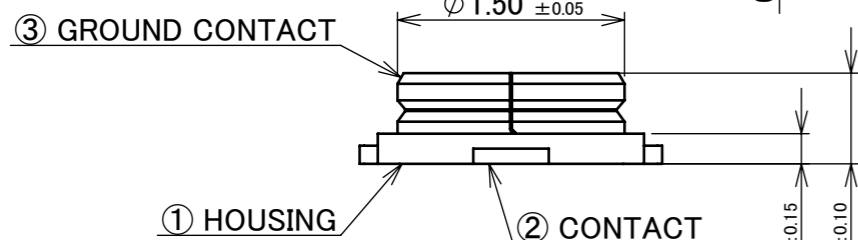
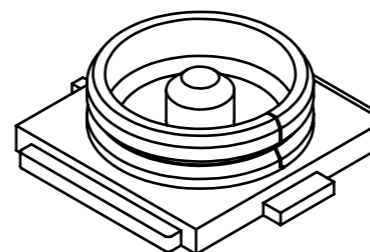

\* MATING HEIGHT  
 1.2 MAX. WITH 20611-001R, 20572-001R-08,  
 20448-00\*R-081, 20448-001R-081E  
 1.4 MAX. WITH 20565-001R-\*\*  
 1.7 MAX. WITH 20632-001R-37  
 (2.0 MAX. WITH MHF 4L LK LOCKED CONDITION)

MATING CONDITION  
 WITH MHF 4/MHF 4L PLUG  
 (S = 10/1)

\* MATING HEIGHT  
 1.2 MAX. WITH 20462-001E

MATING CONDITION  
 WITH MHF 4 SMT  
 (S = 10/1)

NOTES.

- APPLICABLE CONNECTOR (CABLE SIZE)  
 MHF 4 PLUG: 20611-001R (Φ0.81)  
 20448-00\*R-081 (Φ0.81)  
 20448-001R-081E (Φ0.81)  
 MHF 4L PLUG: 20572-001R-08 (Φ0.64, Φ0.81)  
 20565-001R-\*\* (Φ0.83, Φ0.95, Φ1.13)  
 20632-001R-37 (Φ1.37)  
 MHF 4 SMT PLUG: 20462-001E
- COPLANARITY: 0.1 mm MAX.

NO.	DESCRIPTION	MATERIAL	FINISH , REMARKS
3	GROUND CONTACT	PHOSPHOR BRONZE	ALL OVER Ni 1.00 μm MIN. CONTACT PART: Au 0.05 μm MIN. , SOLDERING PART Au AREA: 0.03 μm MIN.
2	CONTACT	BRASS	ALL OVER Ni 1.00 μm MIN. CONTACT PART: Au 0.05 μm MIN. SOLDERING PART Au AREA: 0.03 μm MIN.
1	HOUSING	LCP	UL94V-0, BLACK

14	Z230813	Y.I	2023/07/13	M.T	ANGLE	±2°	6 OVER 30 MAX.	±0.3	PROJECTION ⊕	SERIES No. R1	CUSTOMER COPY	
13	Z230518	K.M	2023/05/10	Y.H	6 MAX.	±0.2	30 OVER 120 MAX.	±0.5				
12	Z230201	TOI	2023/02/20	Y.H	GENERAL TOLERANCE.				TITLE MHF® 4L RECEPTACLE	SCALE 20:1	UNIT mm	I-PEX
11	Z220592	K.W	2022/05/30	Y.H	DWG.	DATE		2014/09/22				
10	Z210723	S.T	2021/07/02	M.T	K.Hashiba							
9	Z210062	TOI	2021/01/22	M.T	T.Tagawa							
REV.	ECN	BY	DATE	APP.	APP.	T.Takano		DWG. No.	20579	SIZE	SHEET	REV.
REVISION RECORD										A3	1/8	14

FOR MHF 4L PLUG

ITEMS	SPECIFICATION	
	20572-001R-08 (CABLE Φ0.81 TYPE)	20565-001E-13 (CABLE Φ1.13 TYPE)
APPLICABLE CONNECTOR PART No.		
RATING VOLTAGE	60 V AC (R.M.S)/DC	
RATING FREQUENCY	DC ~ 12GHz	
OPERATING TEMPERATURE	233~363 K(-40°C~+90°C)	
VSWR (MATED WITH SMA ADAPTER PART No. 90449-002)	1.30 MAX. AT 0.1~3GHz, 1.40 MAX. AT 3~6GHz, 1.50 MAX. 6~9GHz. 1.65 MAX. AT 9~12GHz	
MAIN CONTACT RESISTANCE	INITIAL : 20 mohm MAX. / AFTER TEST : ΔR 20 mohm MAX.	
GROUND CONTACT RESISTANCE	INITIAL : 20 mohm MAX. / AFTER TEST : ΔR 20 mohm MAX.	
INSULATION RESISTANCE	INITIAL : 500 Mohm MIN. / AFTER TEST : 100 Mohm MIN.	
DIELECTRIC WITHSTANDING VOLTAGE	200 V AC 1 MINUTE	
DURABILITY	30 CYCLES	
MATING FORCE (INITIAL / AFTER TEST)	INITIAL : 30 N MAX. / AFTER TEST : 30 N MAX.	
UNMATING FORCE (INITIAL / AFTER TEST)	INITIAL : 20 N MAX. 5 N MIN. / AFTER TEST : 20 N MAX. 3 N MIN.	
PRODUCT SPECIFICATION	PRS-1907	
TEST REPORT	TR-14097	
PACKING STANDARD	20579-001E: PST-14004 20579-001E-01: PST-14067	
INSTRUCTION MANUAL	HIM-12011	HIM-12012
APPEARANCE CRITERIA No.	QLS-A***	

ANGLE	±2°	6 OVER 30 MAX.	±0.3	PROJECTION 	SERIES No. R1	CUSTOMER COPY		
	6 MAX.	±0.2	30 OVER 120 MAX.					±0.5
GENERAL TOLERANCE.				TITLE MHF® 4L RECEPTACLE	SCALE -	I-PEX		
DWG.	DATE							
CHK.								
APP.								
				DWG. No.	20579	SIZE A3	SHEET 2/8	REV. 14

FOR MHF 4 SMT PLUG

ITEMS	SPECIFICATION
APPLICABLE CONNECTOR PART No.	20462-001E (MHF 4 SMT PLUG)
RATING VOLTAGE	60 V AC (R.M.S)/DC
RATING FREQUENCY	DC~12GHz
OPERATING TEMPERATURE	233~363 K(-40°C~+90°C)
VSWR (MATED WITH SMA ADAPTER PART No. 90449-002)	1.30 MAX. AT 0.1~3GHz, 1.40 MAX. AT 3~6GHz, 1.50 MAX. 6~9GHz. 1.65 MAX. AT 9~12GHz
MAIN CONTACT RESISTANCE	INITIAL : 20 mohm MAX. / AFTER TEST : $\Delta$ R 20 mohm MAX.
GROUND CONTACT RESISTANCE	INITIAL : 20 mohm MAX. / AFTER TEST : $\Delta$ R 20 mohm MAX.
INSULATION RESISTANCE	INITIAL : 500 Mohm MIN. AFTER TEST : 100 Mohm MIN.
DIELECTRIC WITHSTANDING VOLTAGE	200 V AC 1 MINUTE
DURABILITY	30 CYCLES
MATING FORCE (INITIAL / AFTER TEST)	INITIAL : 30 N MAX. / AFTER TEST : 15 N MAX.
UNMATING FORCE (INITIAL / AFTER TEST)	INITIAL : 4 N MIN. / AFTER TEST : 2 N MIN.
PRODUCT SPECIFICATION	PRS-1404
TEST REPORT	TR-08022
PACKING STANDARD	20579-001E: PST-14004 20579-001E-01: PST-14067
APPEARANCE CRITERIA No.	QLS-A***

ANGLE	$\pm 2^\circ$	6 OVER 30 MAX.	$\pm 0.3$	PROJECTION 	SERIES No. R1	CUSTOMER COPY		
6 MAX.	$\pm 0.2$	30 OVER 120 MAX.	$\pm 0.5$					
GENERAL TOLERANCE.				TITLE MHF® 4L RECEPTACLE	SCALE	<b>I-PEX</b>		
DWG.	DATE				-			
CHK.					UNIT			
APP.					mm			
				DWG. No.	20579	SIZE	SHEET	REV.
					A3	3/8	14	

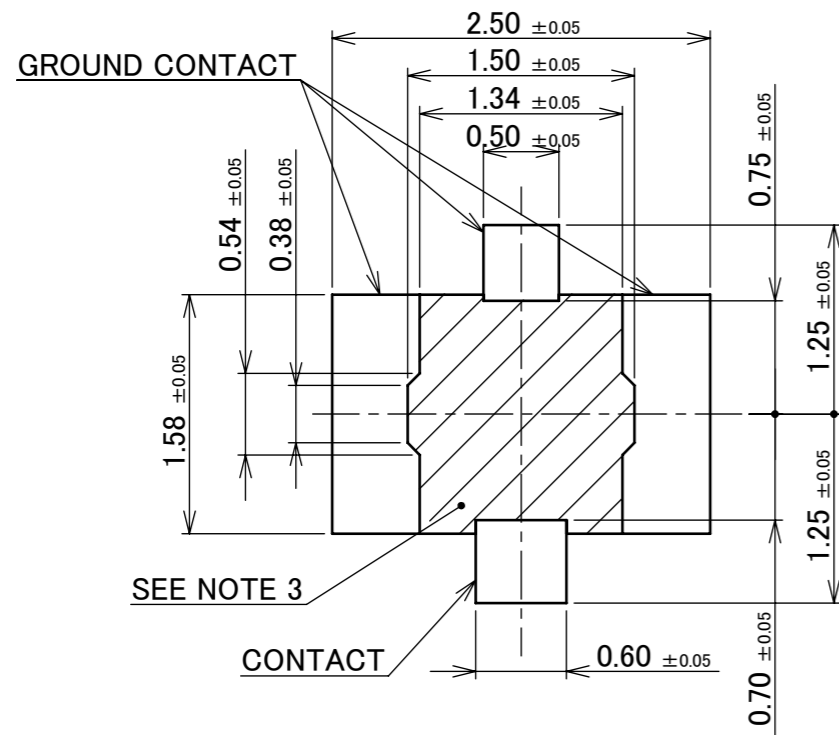

RECOMMENDED FOOTPRINT PATTERN

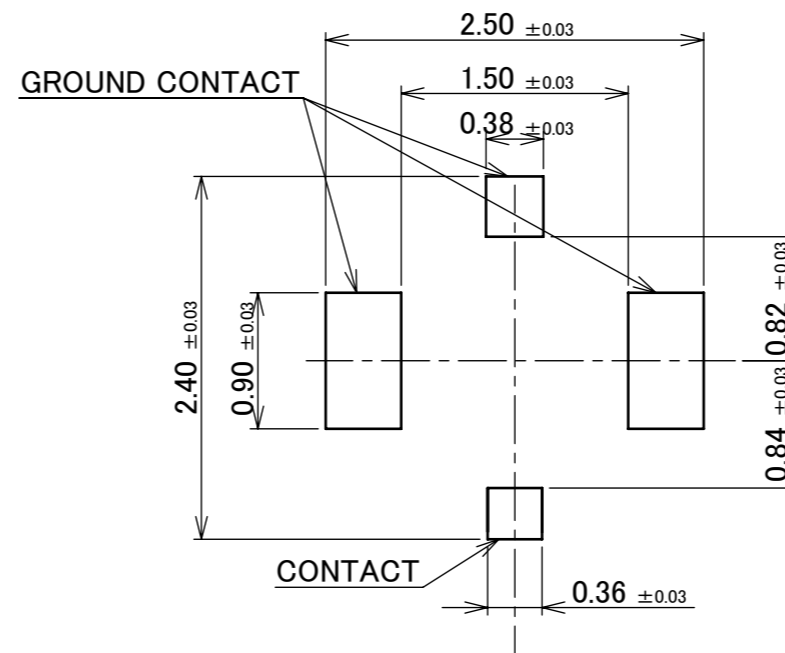

MASK THICKNESS: 0.12 mm

RECOMMENDED METAL MASK LAYOUT

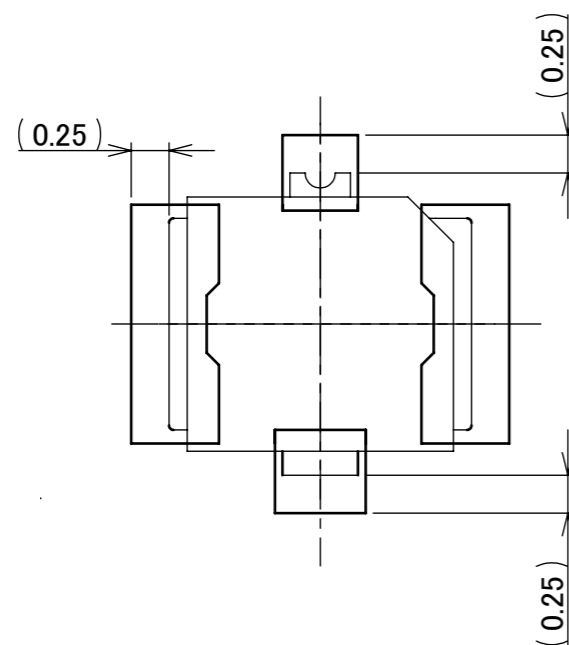

CONNECTOR ON RECOMMENDED FOOTPRINT PATTERN

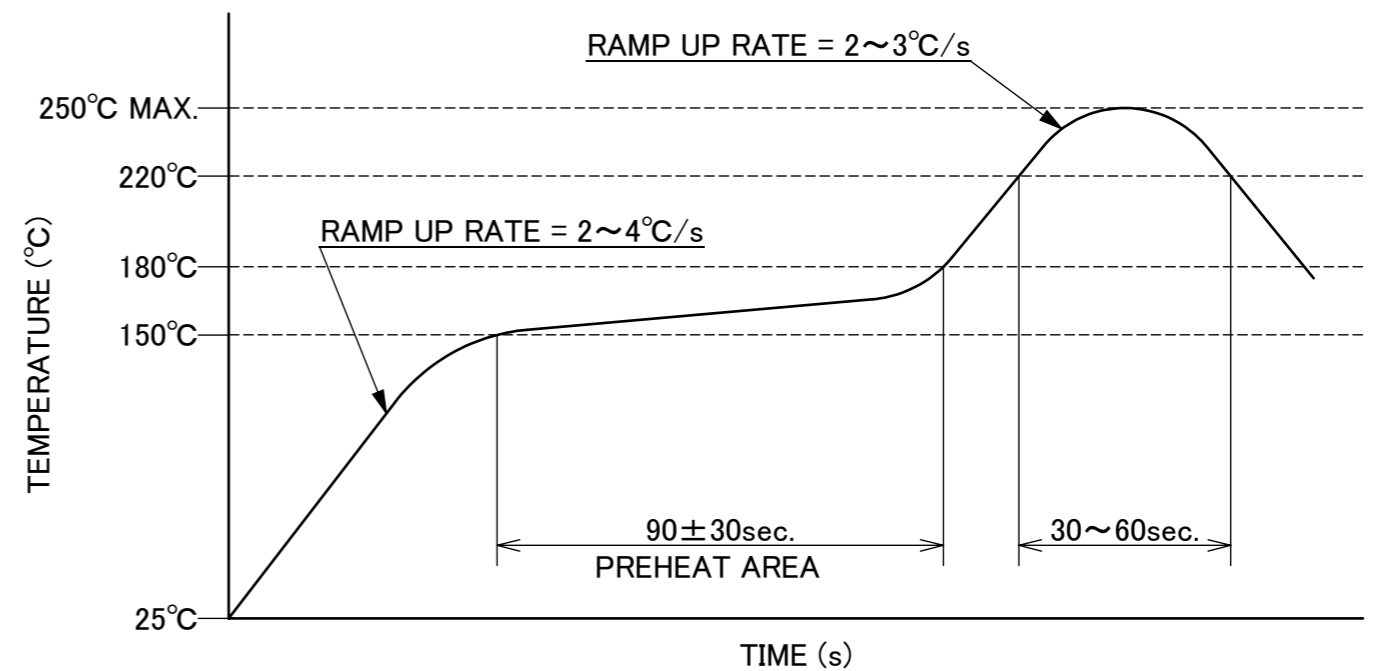

REFLOW TEMPERATURE PROFILE  
SENJU METAL INDUSTRY CO., LTD. : M705-SHF(Sn96.5 Ag3.0 Cu0.5)

NOTE 3. NO GROUND, SIGNAL, AND RESIST IN THIS AREA.

ANGLE	$\pm 2^\circ$	6 OVER 30 MAX.	$\pm 0.3$	PROJECTION ⊕	SERIES No. R1	CUSTOMER COPY						
6 MAX.	$\pm 0.2$	30 OVER 120 MAX.	$\pm 0.5$			SCALE 20:1	I-PEX					
GENERAL TOLERANCE.				TITLE MHF® 4L RECEPTACLE		UNIT mm				SHEET 4/8 REV. 14		
DWG.	DATE			DWG. No. 20579		SIZE A3						
CHK.												
APP.												

# COMPONENT PLACEMENT PROHIBITED AREA FOR MHF 4L RECEPTACLE MATED WITH MHF 4L LK HARNESS REQUIRED AREA FOR RECOMMENDED JIG TO OPERATE

## SINGLE CONNECTOR LAYOUT

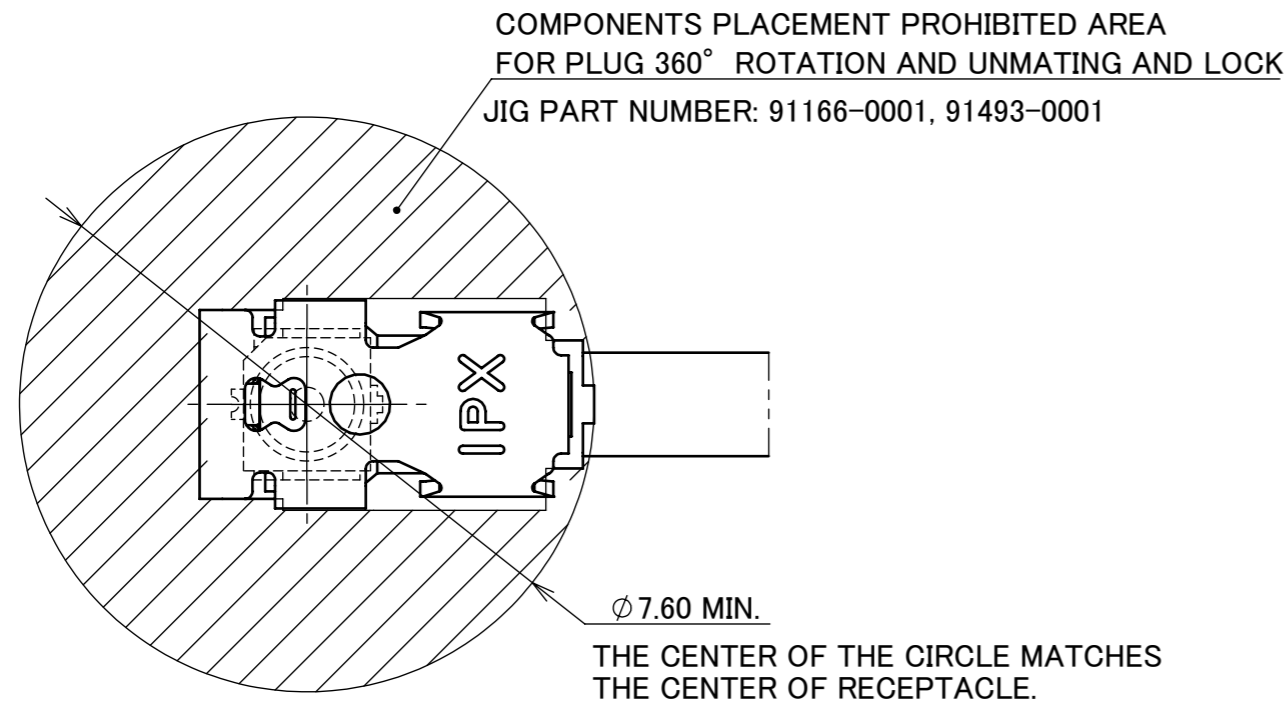

MATING AND LOCK CONDITION  
WITH MHF 4L LK HARNESS

## MULTIPLE CONNECTORS LAYOUT

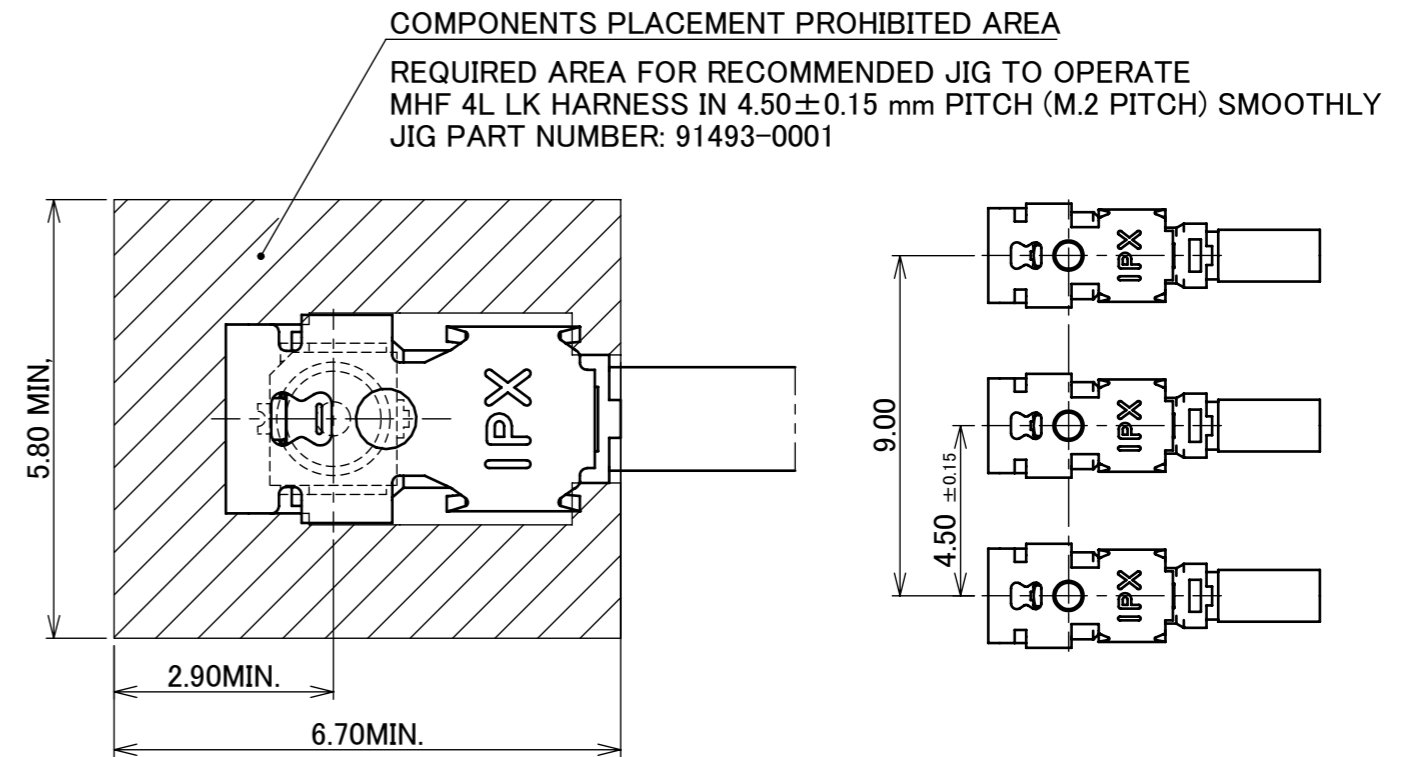

MATING AND LOCK CONDITION  
WITH MHF 4L LK HARNESS NARROW PITCH

MHF 4L LK HARNESS UNLOCK CONDITION  
NARROW PITCH DIMENSIONS  
(S = 5 : 1)

ANGLE	±2°	6 OVER 30 MAX.	±0.3	PROJECTION ⊕	SERIES No. R1	CUSTOMER COPY		
6 MAX.	±0.2	30 OVER 120 MAX.	±0.5					
GENERAL TOLERANCE.				TITLE MHF® 4L RECEPTACLE	SCALE 10:1	UNIT <b>I-PEX</b>		
DWG.	DATE							
CHK.								
APP.								
				DWG. No.	20579	SIZE A3	SHEET 5/8	REV. 14

PART NO.	A	QTY. PER EMBOSS REEL (PIECES / REEL)	QTY. PER PACKING CARTON (REELS / CARTON)
20579-001E	8	10,000 / REEL	9 REELS/ CARTON = 90,000 PIECES

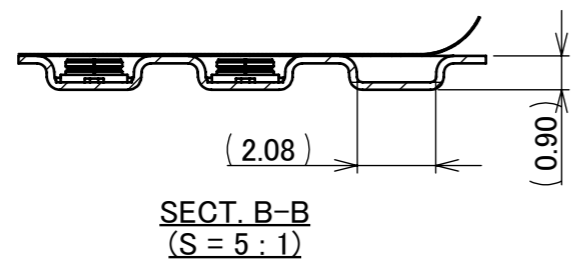
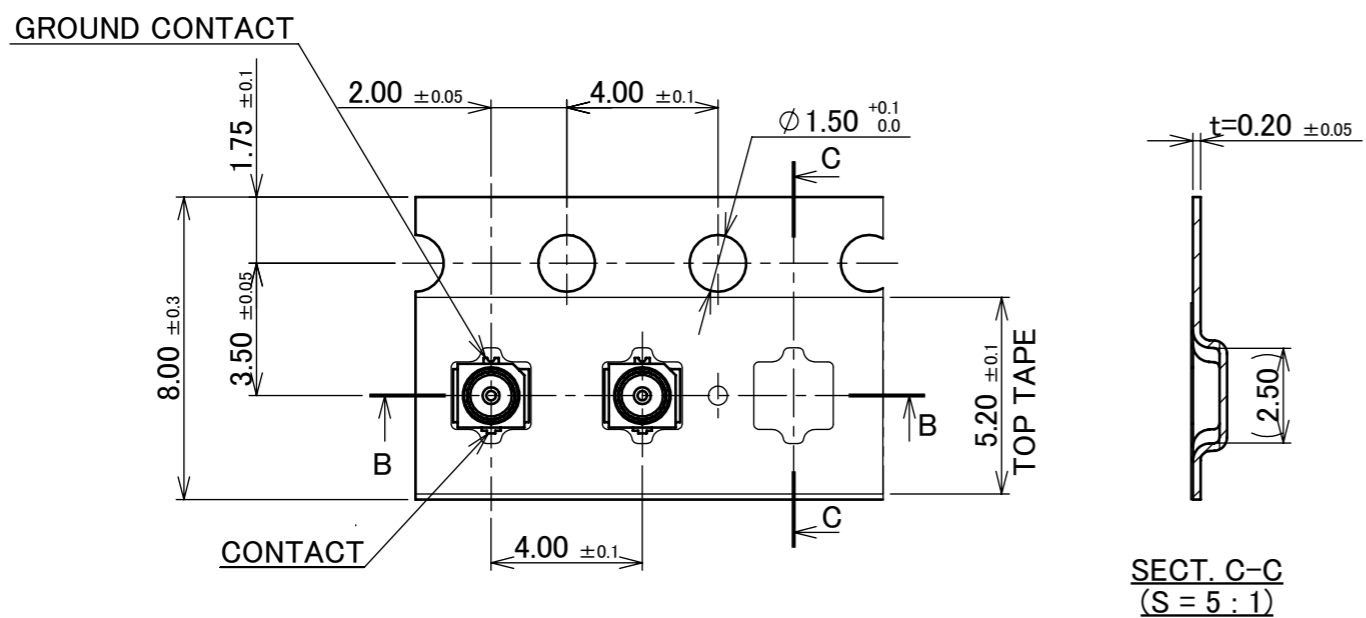
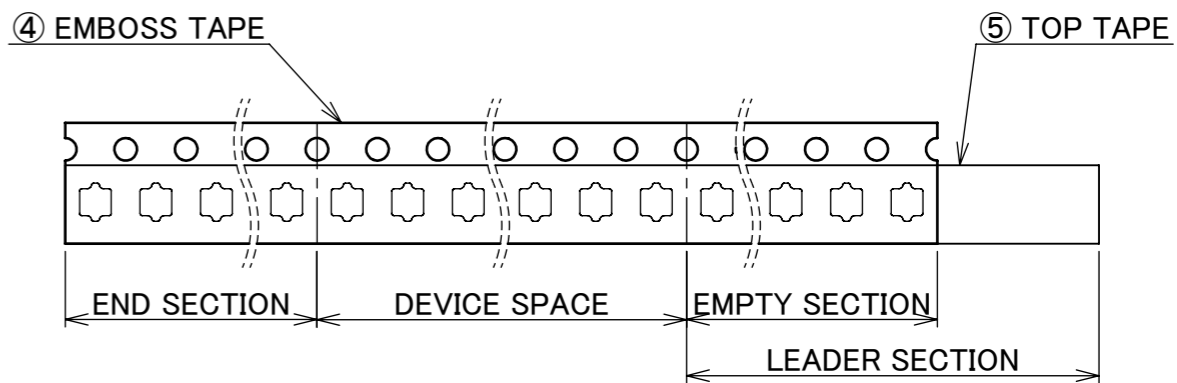
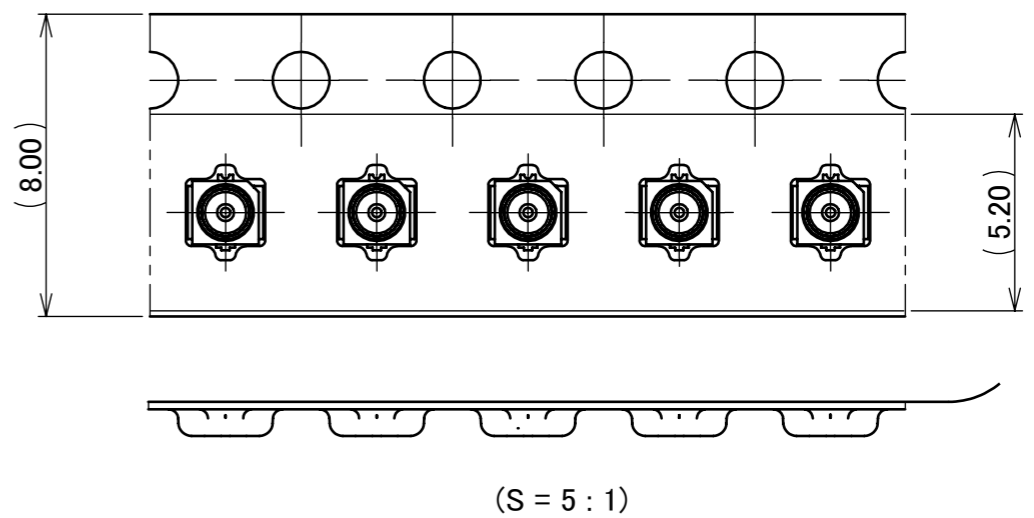
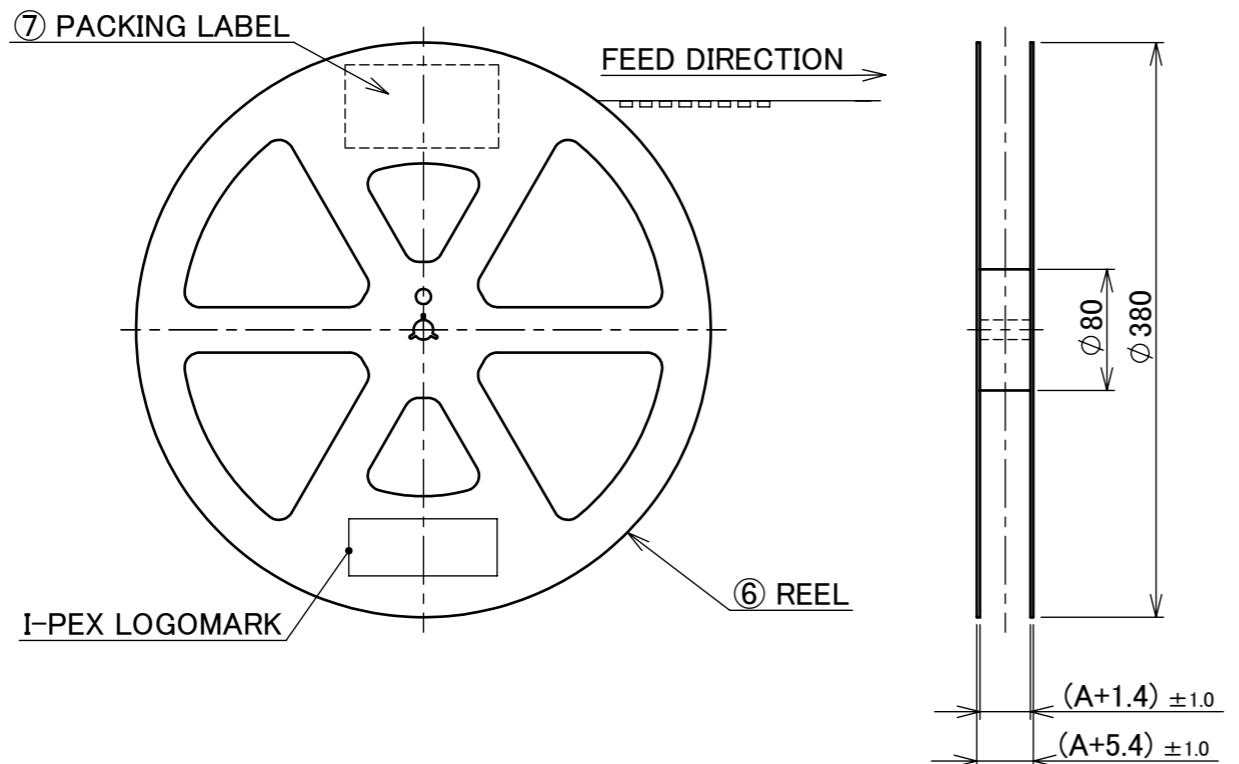

- NOTES.
- TAPING SPECIFICATION FOLLOWS JIS C 0806 (IEC 60286-3).
  - MAKE EMPTY SECTION OF LEADER AND END ON EACH END OF THE TAPE.
  - TOP TAPE SHALL NOT STICK OUT FROM EMBOSS TAPE.
  - TOP TAPE SHALL NOT COVER FEED HOLE.

NO.	DESCRIPTION	MATERIAL	FINISH, REMARKS
7	PACKING LABEL	-	-
6	REEL	PS	ANTI-STATIC TYPE
5	TOP TAPE	PET	ANTI-STATIC TYPE HEAT ACTIVATED
4	EMBOSS TAPE	PS t=0.2	ANTI-STATIC TYPE OR CONDUCTIVE

ANGLE	±2°	6 OVER 30 MAX.	±0.3	PROJECTION ⊕	SERIES No. R1	CUSTOMER COPY		
6 MAX.	±0.2	30 OVER 120 MAX.	±0.5					
GENERAL TOLERANCE.				TITLE MHF® 4L RECEPTACLE	SCALE 1:X	I-PEX		
DWG.	DATE							
CHK.								
APP.								
DWG. No. 20579				SIZE A3	SHEET 6/8	REV. 14		

PART NO.	D	QTY. PER EMBOSS REEL (PIECES / REEL)	QTY. PER PACKING CARTON (REELS / CARTON)
20579-001E-01	8	20,000 / REEL	10 REELS/ CARTON = 200,000 PIECES

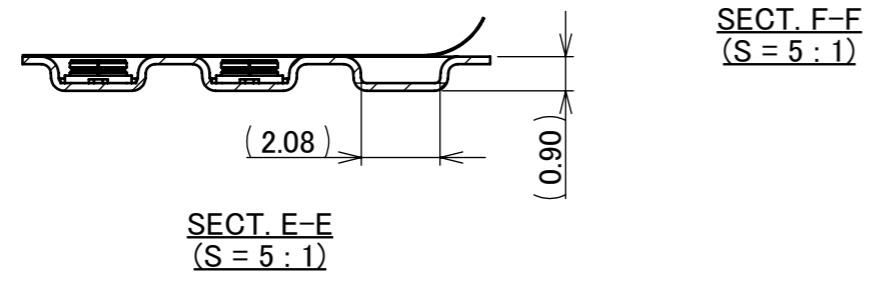
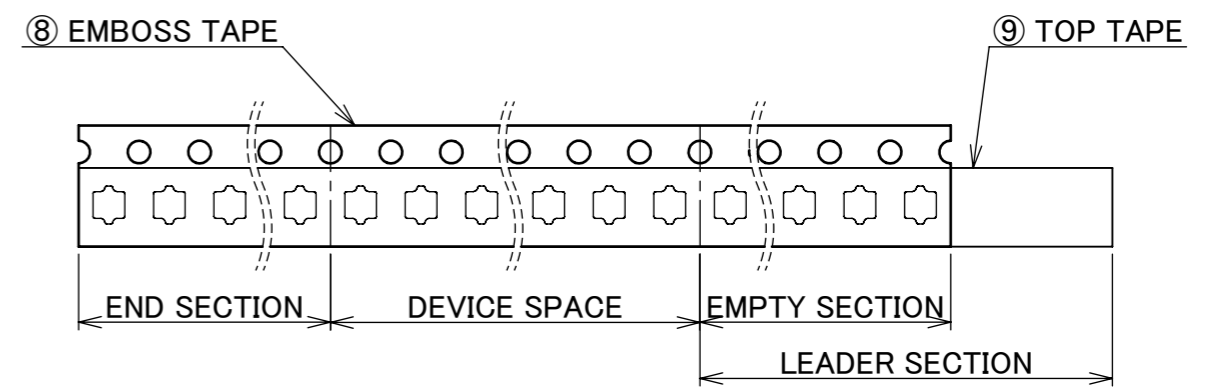
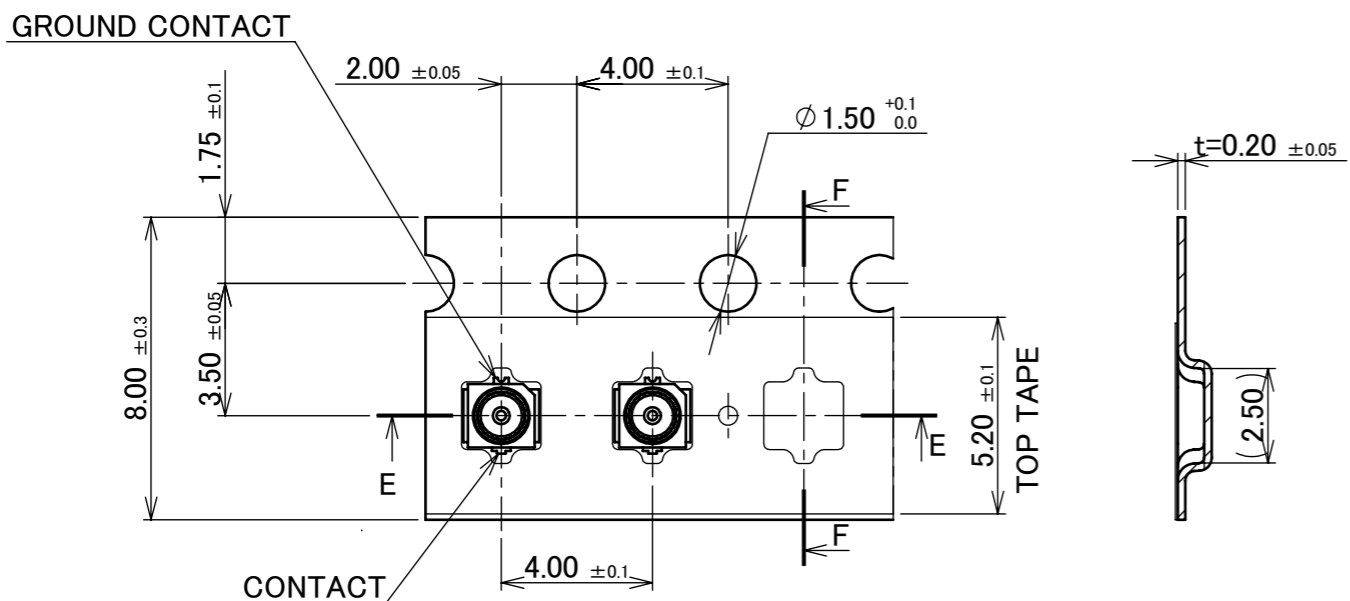
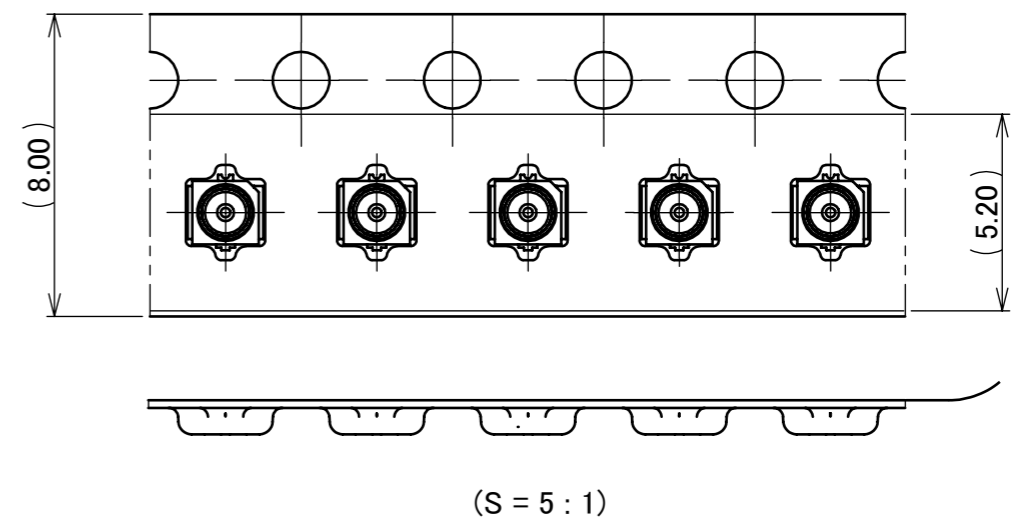
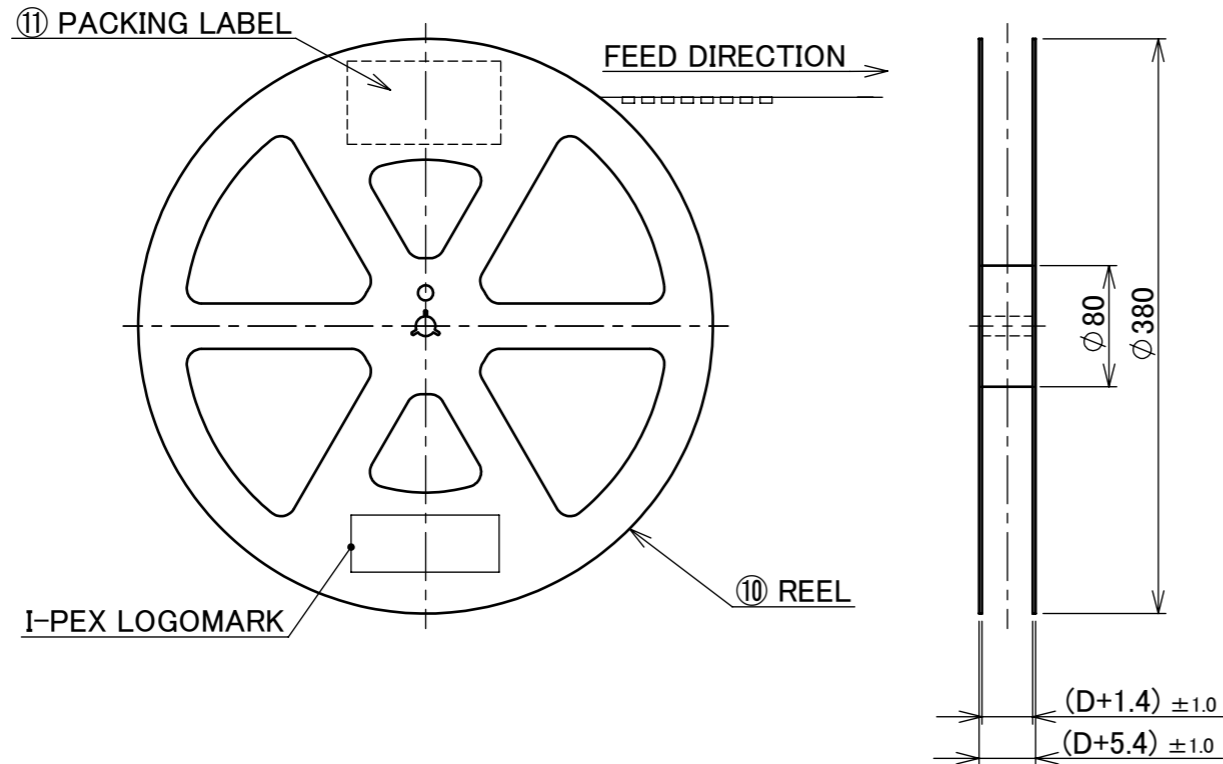

- NOTES.  
8. TAPING SPECIFICATION FOLLOWS JIS C 0806 (IEC 60286-3).  
9. MAKE EMPTY SECTION OF LEADER AND END ON EACH END OF THE TAPE.  
10. TOP TAPE SHALL NOT STICK OUT FROM EMBOSS TAPE.  
11. TOP TAPE SHALL NOT COVER FEED HOLE.

NO.	DESCRIPTION	MATERIAL	FINISH, REMARKS
11	PACKING LABEL	-	-
10	REEL	PS	ANTI-STATIC TYPE
9	TOP TAPE	PET	ANTI-STATIC TYPE HEAT ACTIVATED
8	EMBOSSE TAPE	PS t=0.2	ANTI-STATIC TYPE OR CONDUCTIVE

ANGLE	±2°	6 OVER 30 MAX.	±0.3	PROJECTION ⊕	SERIES No. R1	CUSTOMER COPY			
	6 MAX.	±0.2	30 OVER 120 MAX.						±0.5
GENERAL TOLERANCE.				TITLE MHF® 4L RECEPTACLE	SCALE 1:X	I-PEX			
DWG.	DATE								UNIT mm
CHK.									SIZE A3
APP.									SHEET 7/8
				DWG. No.	20579				

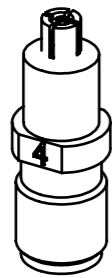

MHF 4 (4L) SMA ADAPTER  
PART NO. 90449-002



MHF 4 RECEPTACLE HIGH CYCLE ATTACHMENT  
PART NO. 90683-0001

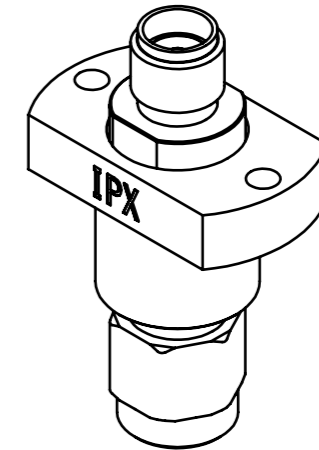

MHF SERIES HIGH CYCLE SMA ADAPTER BASE UNIT  
PART NO. 90684-0001

\* 90683-0001 AND 90684-0001 SHOULD BE USED TOGETHER.

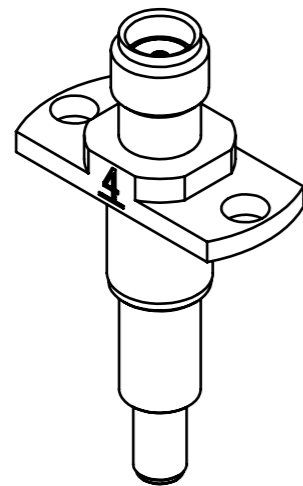

MHF 4 (4L) RECEPTACLE HIGH CYCLE SMA ADAPTER  
PART NO. 90698-0001

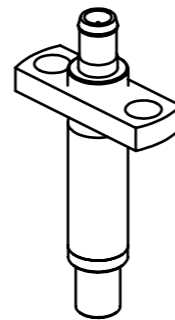

MHF 4 (4L) RECEPTACLE HIGH CYCLE N45 C ADAPTER  
PART NO. 90576-0001

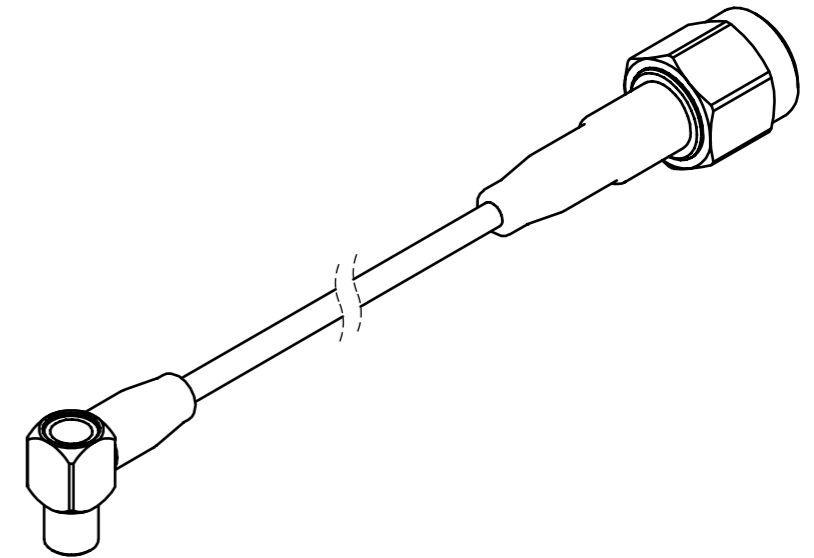

MHF SERIES N45 C TO SMA ADAPTER CABLE  
PART NO. 90577-\*\*\*\*

\* 90576-0001 AND 90577-\*\*\*\* SHOULD BE USED TOGETHER.

ANGLE	±2°	6 OVER 30 MAX.	±0.3	PROJECTION ⊕	SERIES No. R1	CUSTOMER COPY		
6 MAX.	±0.2	30 OVER 120 MAX.	±0.5					
GENERAL TOLERANCE.				TITLE MHF® 4L RECEPTACLE		SCALE	<b>I-PEX</b>	
DWG.	DATE					-		
CHK.						UNIT		
APP.						mm		
				DWG. No.	20579	SIZE	SHEET	REV.
						A3	8/8	14