

PART NO.
20565-001R-13

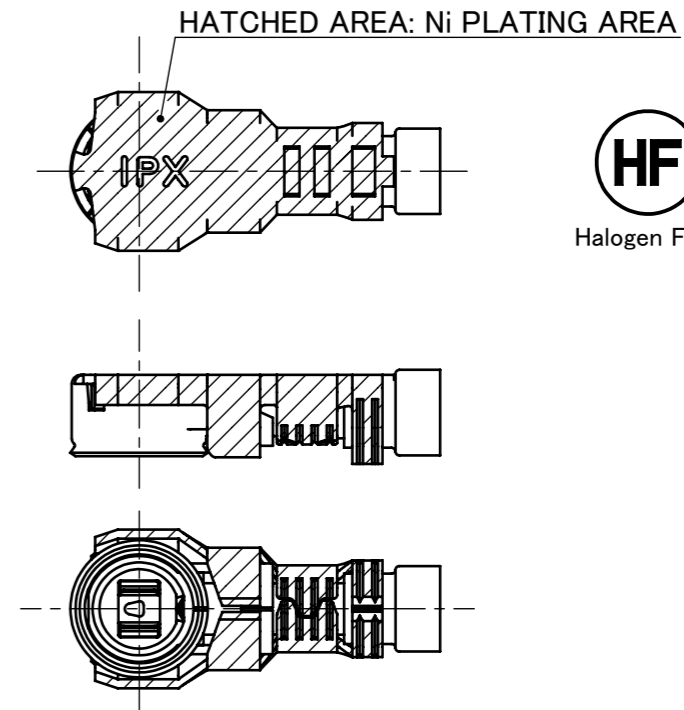

HF
Halogen Free

RoHS
COMPLIANT
RoHS Compliant

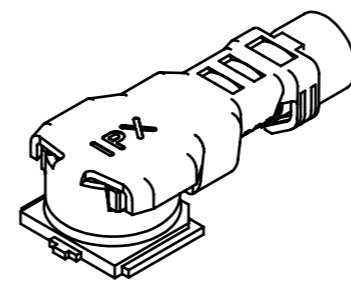
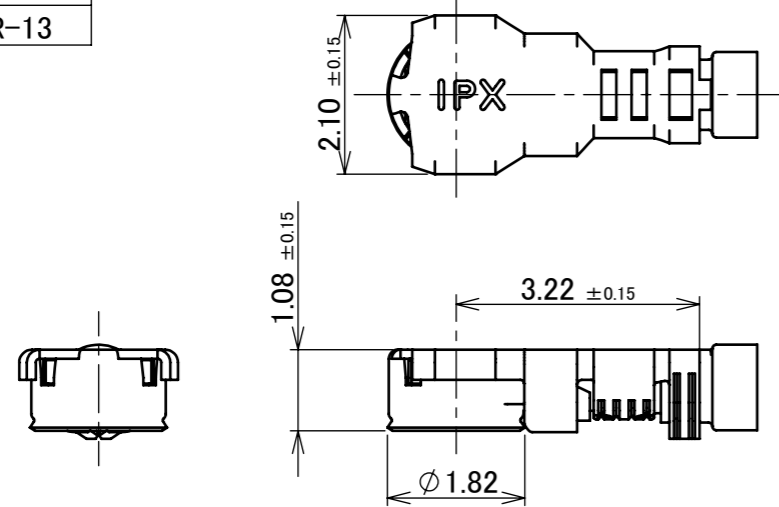
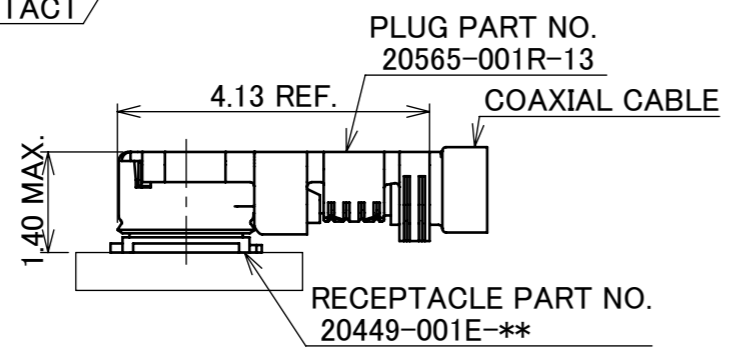
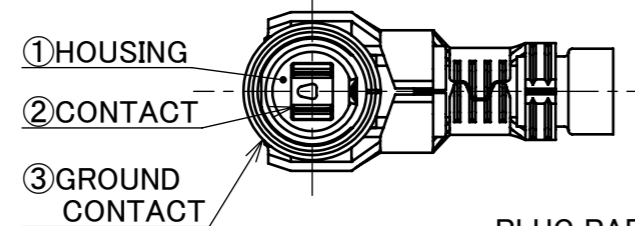

MATING CONDITION

NOTES.

1. APPLICABLE CONNECTOR
20449-001E-**
20579-001E-**
2. MATING AND UNMATING INSTRUCTION
 - 2-1. MATING
MATE THE CONNECTOR VERTICALLY AS MUCH AS POSSIBLE, ADJUSTING THE MATING AXIS OF PLUG AND RECEPTACLE. DO NOT SLANT MATE.
 - 2-2. UNMATING INSTRUCTION
 - 2-2-1. IN CASE OF UNMATING BY PULLING TOOL (PART NO. 90609-0001)
USE THE PULLING TOOL AS THE FOLLOWING DRAWING, AND PULL PLUG TO VERTICAL DIRECTION AS DIRECTLY AS POSSIBLE.
 - 2-2-2. IN CASE OF UNMATING DIRECTLY BY HAND
CATCH THE CATCHING AREA OF PLUG, AND PULL PLUG TO VERTICAL DIRECTION AS DIRECTLY AS POSSIBLE.

NOTE 2-1.

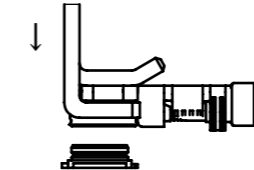

NOTE 2-2-1.

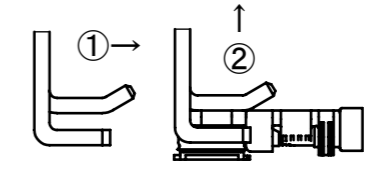

NOTE 2-2-2.

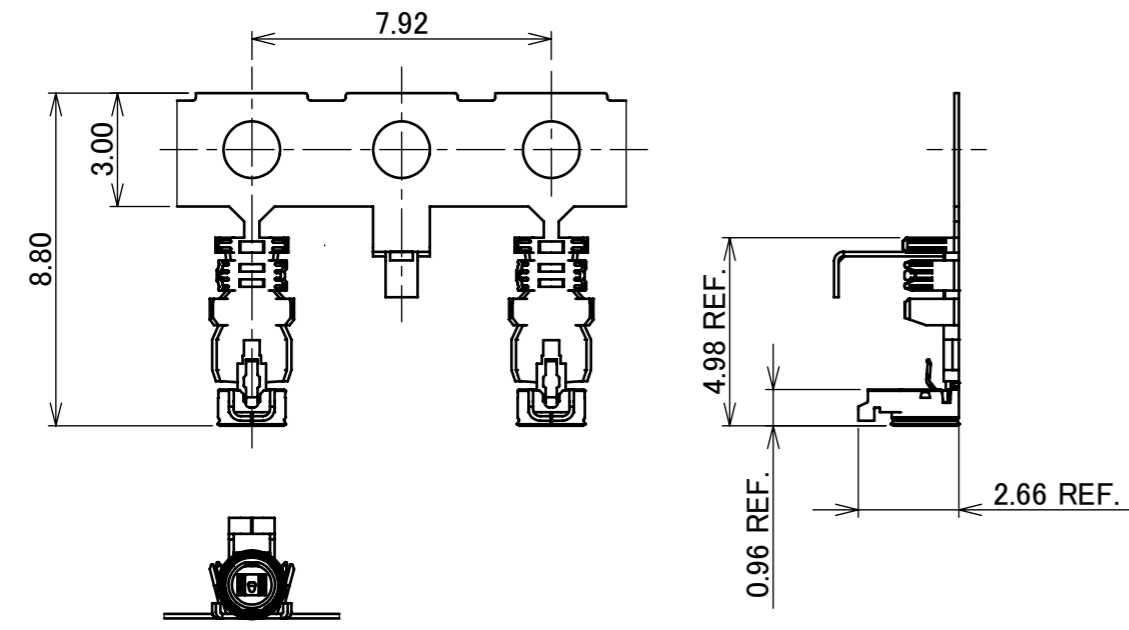
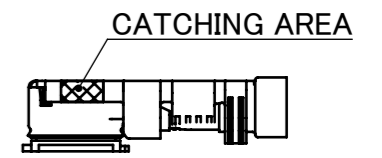

CARRIER CONDITION
S = 5:1

NO.	DESCRIPTION	MATERIAL	FINISH , REMARKS
3	GROUND CONTACT	PHOSPHOR BRONZE	ALL OVER Ni 1.00 μm MIN. CONTACT PART Au 0.05 μm MIN. [Ni PLATING AREA] Ni ONLY
2	CONTACT	PHOSPHOR BRONZE	ALL OVER Ni 1.00 μm MIN. CONTACT PART Au 0.10 μm MIN.
1	HOUSING	PBT	UL94V-0, BLACK

REV.	ECN	BY	DATE	APP.	APP.	CHK.	DATE	ANGLE	PROJECTION	SERIES No.	TITLE	SCALE	UNIT	SHEET	REV.
10	Z220982	TOI	2022/08/30	Y.H	ANGLE	±2°	6 OVER 30 MAX.	±0.3		R8	MHF® 4L PLUG Ni TOP (1.13, 0.95, 0.83)	10:1	mm	1/7	10
9	Z220756	K.W	2022/07/04	Y.H	6 MAX.	±0.2	30 OVER 120 MAX.	±0.5							
8	Z220592	K.W	2022/05/30	Y.H	GENERAL TOLERANCE.										
7	Z201096	TOI	2020/10/21	M.T	DWG.	S.Suzuki	DATE	2013/08/02							
6	Z201062	TOI	2020/10/13	M.T	CHK.	K.Yotsutani									
5	Z191019	Haji	2019/08/01	Y.S	APP.	T.Takano									
REVISION RECORD															

PART NO.
20565-001R-83

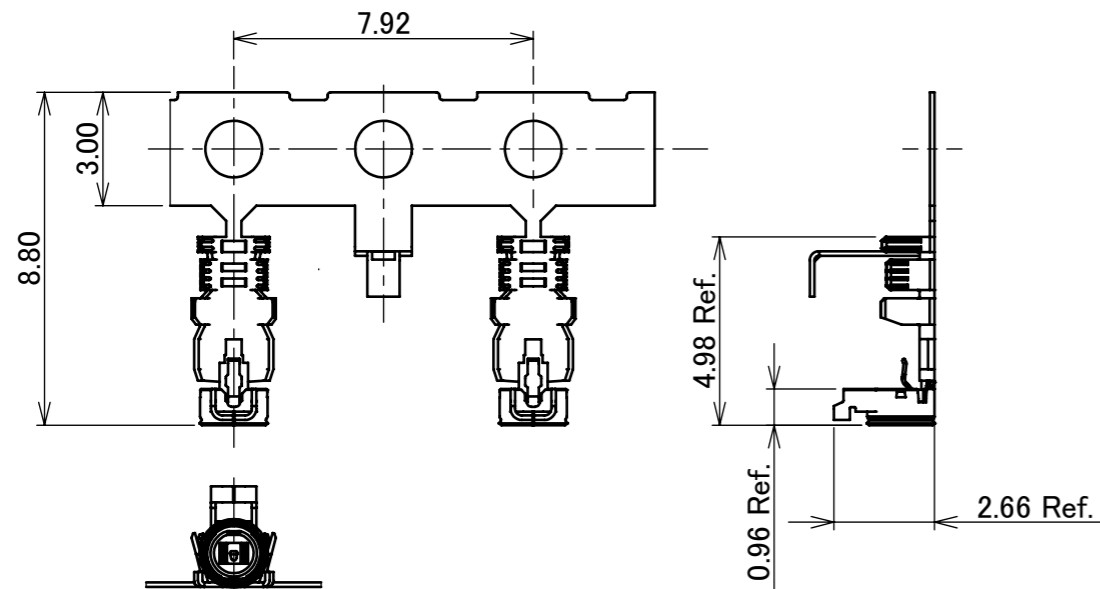
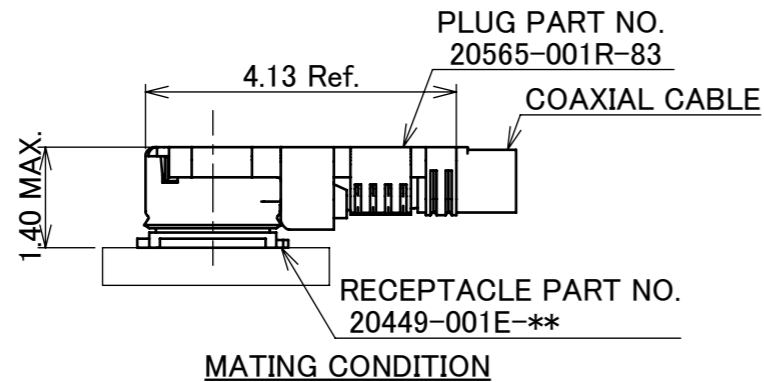
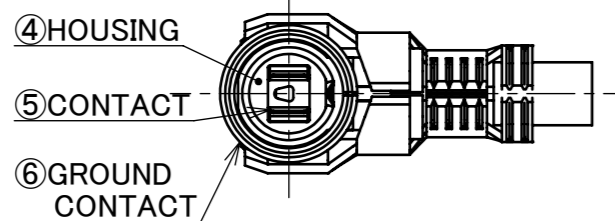
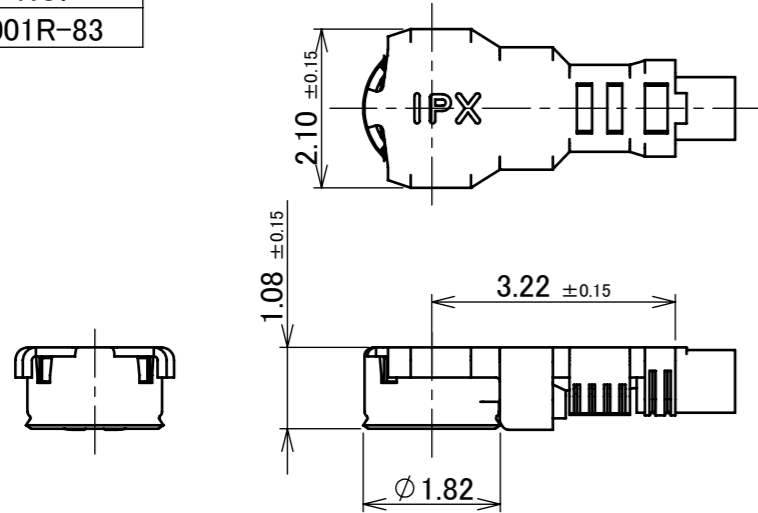

CARRIER CONDITION
S = 5:1

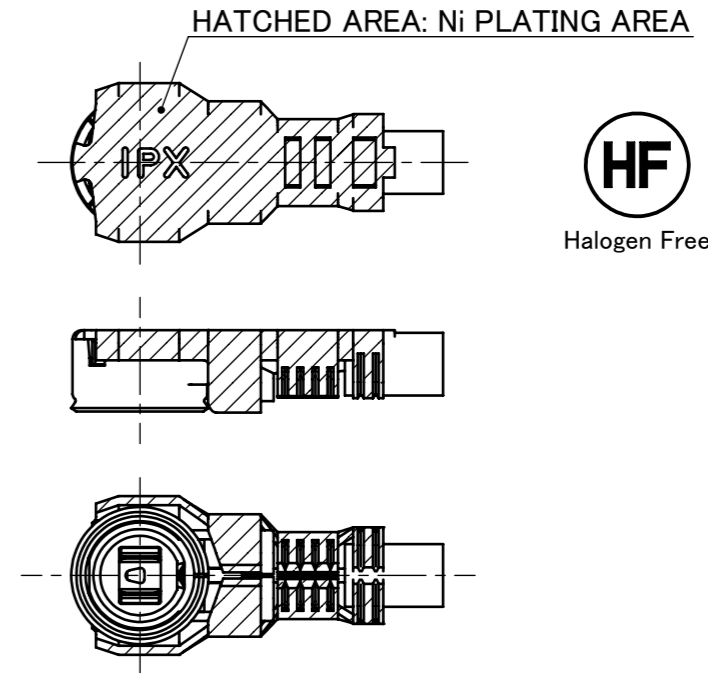
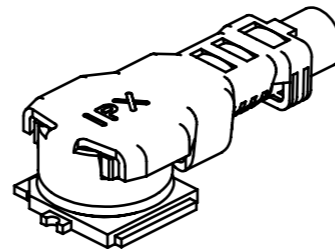

NOTES.

3. APPLICABLE CONNECTOR:

- 20449-001E-**
- 20579-001E-**

4. MATING AND UNMATING INSTRUCTION

4-1. MATING

MATE THE CONNECTOR VERTICALLY AS MUCH AS POSSIBLE, ADJUSTING THE MATING AXIS OF PLUG AND RECEPTACLE. DO NOT SLANT MATE.

4-2. UNMATING INSTRUCTION

4-2-1. IN CASE OF UNMATING BY PULLING TOOL (PART NO. 90609-0001)

USE THE PULLING TOOL AS THE FOLLOWING DRAWING, AND PULL PLUG TO VERTICAL DIRECTION AS DIRECTLY AS POSSIBLE.

4-2-2. IN CASE OF UNMATING DIRECTLY BY HAND

CATCH THE CATCHING AREA OF PLUG, AND PULL PLUG TO VERTICAL DIRECTION AS DIRECTLY AS POSSIBLE.

NOTE 4-1.

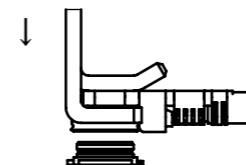

NOTE 4-2-1.

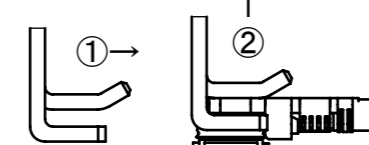

NOTE 4-2-2.

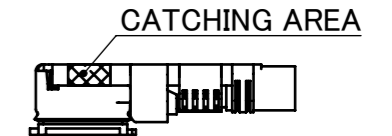

NO.	DISCRIPTION	MATERIAL	FINISH , REMARKS
6	GROUND CONTACT	PHOSPHOR BRONZE	ALL OVER Ni 1.00 μ m MIN. CONTACT PART Au 0.05 μ m MIN. [Ni PLATING AREA] Ni ONLY
5	CONTACT	PHOSPHOR BRONZE	CONTACT PART FINISH: Au 0.10 μ m MIN. UNDER PLATE: Ni 1.00 μ m MIN.
4	HOUSING	PBT	UL94V-0, BLACK

REVISION RECORD					ANGLE	±2°	6 OVER 30 MAX.	±0.3	PROJECTION ⊕	SERIES No. R8	CUSTOMER COPY	
						6 MAX.	±0.2	30 OVER 120 MAX.				
REV. ECN BY DATE APP.					GENERAL TOLERANCE.				TITLE MHF® 4L PLUG Ni TOP (1.13, 0.95, 0.83)	SCALE 10:1	UNIT mm	
					DWG. DATE							

ITEMS	SPECIFICATION		
	APPLICABLE CABLE	AWG#32 (1.13 O.D.)	AWG#33 (0.95 O.D.)
RECOMMENDED APPLICABLE CONNECTOR PART No.	20449-001E-**		
RATING VOLTAGE	60 V AC (R.M.S)		
RATING FREQUENCY (MATED WITH MHF 4 RECEPTACLE PART No.20449-001E-**)	DC~ 9GHz		
OPERATING TEMPERATURE	233~363 K (-40°C~+90°C)		
VSWR (MATED WITH SMA ADAPTER PART No. 90449-001)	1.30 MAX. AT 0.1~3GHz, 1.45 MAX. AT 3~6GHz, 1.60 MAX. AT 6~9GHz, 1.90 MAX. AT 9~12GHz		
MAIN CONTACT RESISTANCE	INITIAL: 20 mohm MAX. / AFTER TEST: \triangle R 20 mohm MAX.		
GROUND CONTACT RESISTANCE	INITIAL: 20 mohm MAX. / AFTER TEST: \triangle R 20 mohm MAX.		
INSULATION RESISTANCE	INITIAL: 500 Mohm MIN. / AFTER TEST: 100 Mohm MIN.		
DIELECTRIC WITHSTANDING VOLTAGE	200 V AC, 1 MINUTE		
DURABILITY	30 CYCLES		
MATING FORCE (INITIAL / AFTER TEST)	INITIAL: 30 N MAX. / AFTER TEST: 30 N MAX.		
UNMATING FORCE (INITIAL / AFTER TEST)	INITIAL: 20 N MAX. 5 N MIN. / AFTER TEST: 20 N MAX. 3 N MIN.		
PRODUCT SPECIFICATION	PRS-1772	PRS-2051	PRS-2062
TEST REPORT	TR-13011	TR-14142	TR-15011
PACKING STANDARD	PST-12066		
INSTRUCTION MANUAL	HIM-12012		
APPEARANCE CRITERIA No.	QLS-A***		

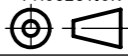
ANGLE	$\pm 2^\circ$	6 OVER 30 MAX.	± 0.3	PROJECTION 	SERIES No. R8	CUSTOMER COPY	
6 MAX.	± 0.2	30 OVER 120 MAX.	± 0.5				
GENERAL TOLERANCE.				TITLE MHF® 4L PLUG Ni TOP (1.13, 0.95, 0.83)	SCALE	I-PEX	
DWG.	DATE				-		
CHK.					UNIT		
APP.					mm		
				DWG. No.	20565	SIZE	SHEET
						A3	3/7
							REV.
							10

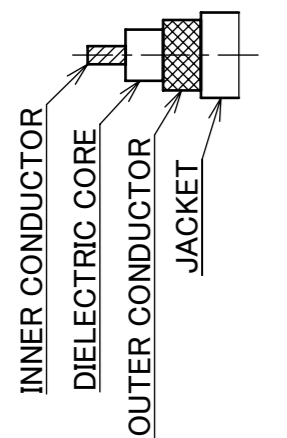
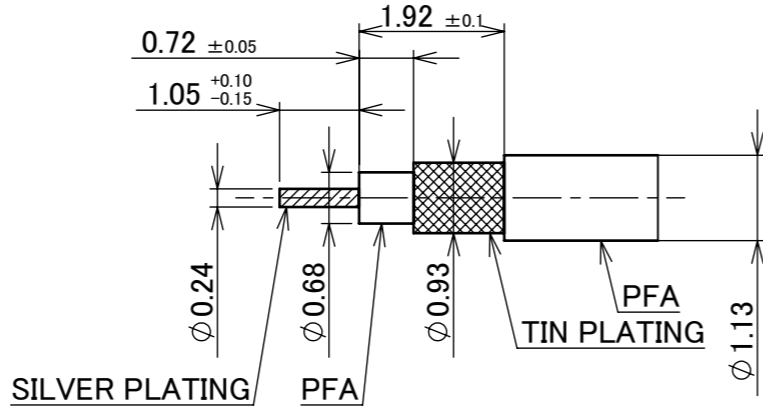
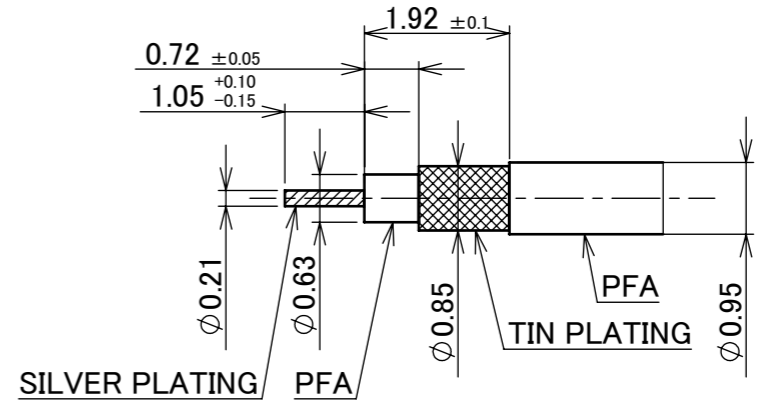
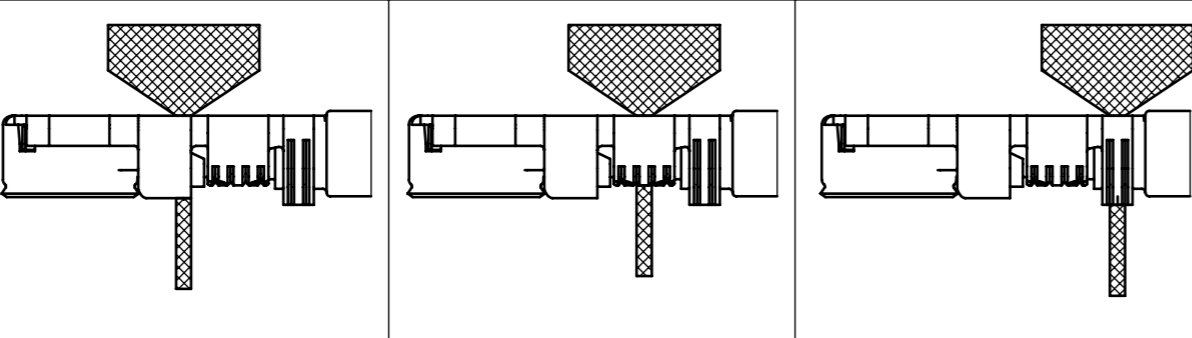
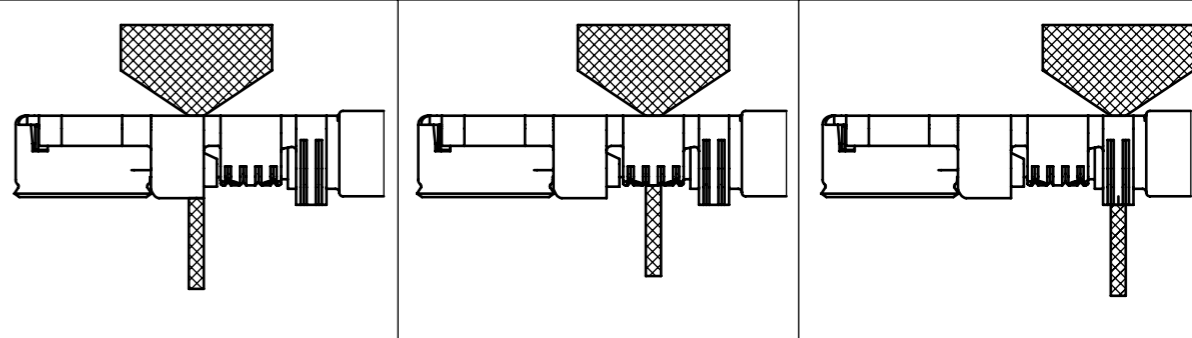
PART NO.	20565-001R-13					
<p>APPLICABLE CABLE STRIP DIMENSION</p> 	 <p>※DO NOT USE SOLDER COATED EITHER INNER OR OUTER CONDUCTOR CABLES.</p>			 <p>※DO NOT USE SOLDER COATED EITHER INNER OR OUTER CONDUCTOR CABLES.</p>		
<p>REQUIREMENTS</p> <p>CHARACTERISTIC IMPEDANCE: 50 ohm by TDR METHOD</p> <p>NOMINAL CAPACITACNE (REFERENCE VALUE): 97pF/m</p> <p>CONDUCTOR RESISTANCE OF INNER CONDUCTOR AT 293K (REFERENCE VALUE): OD 1.13 TYPE...520 ohm/km OD 0.95 TYPE...752 ohm/km</p> <p>INSULATION RESISTANCE: OD1.13 TYPE...1500 Mega-ohm.km MIN. OD0.95 TYPE...1000 Mega-ohm.km MIN.</p> <p>DIELECTRIC WITHSTAND VOLTAGE: OD1.13 TYPE...NO BREAKDOWN AT AC1000V FOR 1 MINUTE. OD0.95 TYPE...NO BREAKDOWN AT AC500V FOR 1 MINUTE.</p>						
BRAIDED SHIELD OF OUTER CONCUCTOR	SINGLE BRAIDED SHIELD			SINGLE BRAIDED SHIELD		
PART NO. OF SEMI AUTO TERMINATION MACHINE	90600-013			90600-010		
CRIMP HEIGHT	<p>※USE FOR POINT MICROMETER.</p> 			<p>※USE FOR POINT MICROMETER.</p> 		
	CH-1 (i-Fit® PART) 1.07~1.11	CH-2 (SHIELD PART) 0.90~0.94	CH-3 (JACKET PART) 1.16~1.20	CH-1 (i-Fit® PART) 1.04~1.08	CH-2 (SHIELD PART) 0.92~0.96	CH-3 (JACKET PART) 1.16~1.20

ANGLE	±2°	6 OVER 30 MAX.	±0.3	PROJECTION 	SERIES No. R8	CUSTOMER COPY		
	6 MAX.	±0.2	30 OVER 120 MAX.					±0.5
GENERAL TOLERANCE.				TITLE MHF® 4L PLUG Ni TOP (1.13, 0.95, 0.83)	SCALE -	I-PEX		
DWG.	DATE							
CHK.								
APP.								
				DWG. No.	20565	SIZE A3	SHEET 4/7	REV. 10

PART NO.	20565-001R-83		
APPLICABLE CABLE STRIP DIMENSION	<p>※DO NOT USE SOLDER COATED EITHER INNER OR OUTER CONDUCTOR CABLES.</p>		
	<p>REQUIREMENTS</p> <p>CHARACTERISTIC IMPEDANCE: 50 ohm BY TDR METHOD</p> <p>NOMINAL CAPACITANCE(REFERENCE VALUE): 96pF/m</p> <p>CONDUCTOR RESISTANCE OF INNER CONDUCTOR AT 293K (Reference value): 925 ohm/km</p> <p>INSULATION RESISTANCE: 1000 Mega-ohm.km MIN.</p> <p>DIELECTRIC WITH STANCE VOLTAGE: NO BREAKDOWN AT AC 1500V FOR 1 MINUTE.</p>		
BRAIDED SHIELD OF OUTER CONDUCTOR	SINGLE BRAIDED SHIELD		
PART NO. OF SEMI AUTO TERMINATION MACHINE	90600-083		
	※USE FOR POINT MICROMETER		
CRIMP HEIGHT	<p>CH-1 (i-Fit® PART) 0.91~0.95</p>	<p>CH-2 (SHIELD PART) 0.84~0.88</p>	<p>CH-3 (JACKET PART) 0.82~0.86</p>

ANGLE	±2°	6 OVER 30 MAX.	±0.3	PROJECTION 	SERIES No. R8	CUSTOMER COPY		
	6 MAX.	±0.2	30 OVER 120 MAX.					±0.5
GENERAL TOLERANCE.				TITLE MHF® 4L PLUG Ni TOP (1.13, 0.95, 0.83)	SCALE -	I-PEX		
DWG.	DATE							
CHK.								
APP.								
				DWG. No.	20565	SIZE A3	SHEET 5/7	REV. 10

PART NO.	A	QTY. PER EMBOSS REEL (PIECES / REEL)	QTY. PER PACKING CARTON (REELS / CARTON)
20565-001R-**	15	3,000 / REEL	7 REELS / CARTON = 21,000 PIECES

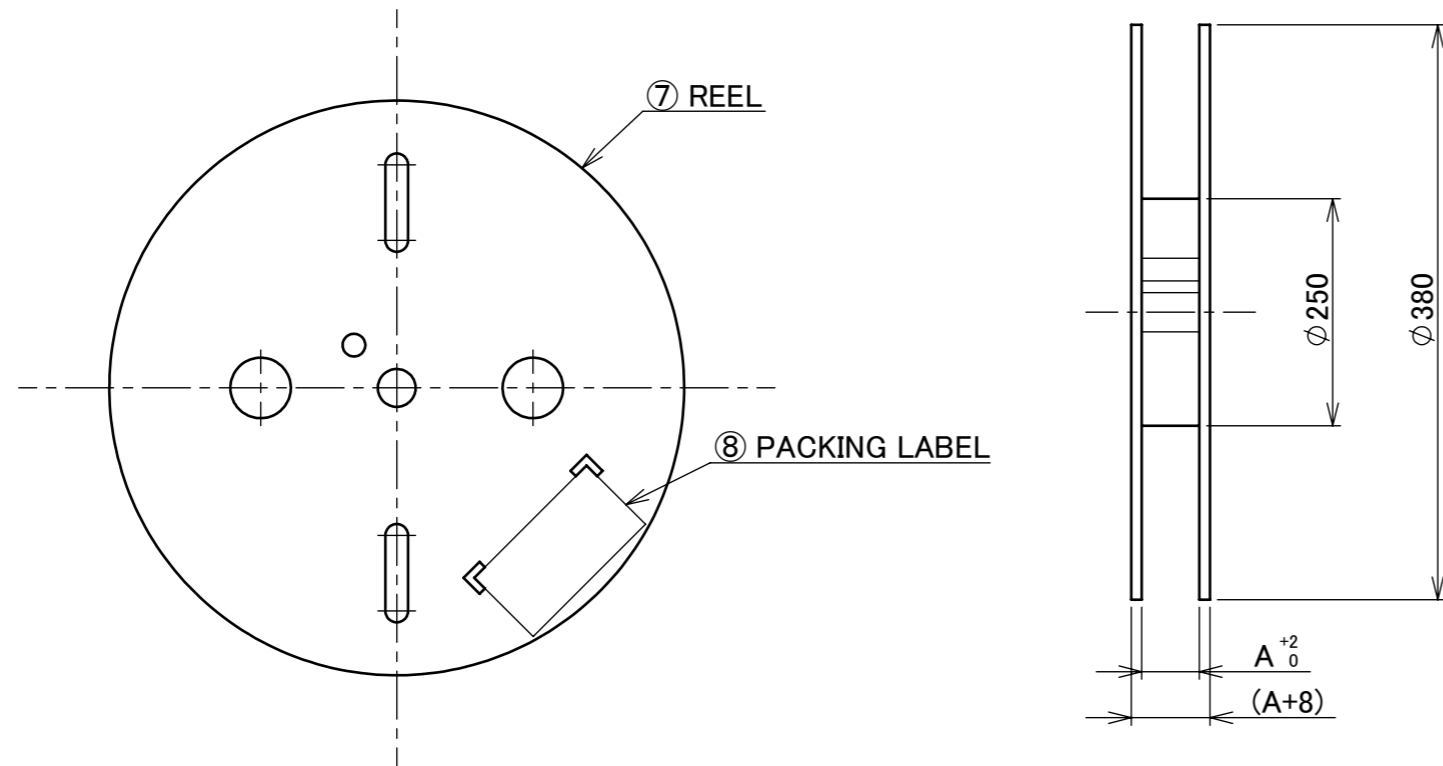

8	PACKING LABEL	-	-
7	REEL	PP	-
NO.	DISCRIPTION	MATERIAL	FINISH , REMARKS

ANGLE	±2°	6 OVER 30 MAX.	±0.3	PROJECTION ⊕	SERIES No. R8	CUSTOMER COPY		
6 MAX.	±0.2	30 OVER 120 MAX.	±0.5					
GENERAL TOLERANCE.				TITLE MHF® 4L PLUG Ni TOP (1.13, 0.95, 0.83)	SCALE -	UNIT mm		
DWG.	DATE							
CHK.								
APP.								
				DWG. No.	20565	SIZE A3	SHEET 6/7	REV. 10

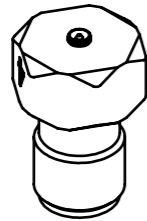

MHF 4 (4L) SMA ADAPTOR
PART NO. 90449-001

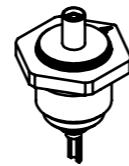

MHF 4 (4L) INSPECTION CONNECTOR
PART NO. 90449-003-01



FRONT SIDE



BACK SIDE

MHF 4L PUSHING AND PULLING TOOL
PART NO. 90609-0001

ANGLE	±2°	6 OVER 30 MAX.	±0.3	PROJECTION ⊕	SERIES No. R8	CUSTOMER COPY		
6 MAX.	±0.2	30 OVER 120 MAX.	±0.5					
GENERAL TOLERANCE.				TITLE MHF® 4L PLUG Ni TOP (1.13, 0.95, 0.83)	SCALE 2:1	UNIT I-PEX		
DWG.	DATE							
CHK.								
APP.								
				DWG. No.	20565	SIZE A3	SHEET 7/7	REV. 10