

PART NO.	L
8-25-0950	300.00±3.0 mm

PLEASE CONTACT I-PEX FOR REQUESTS OTHER THAN THIS SPECIFICATIONS.  
PLEASE NOTE IF SPECIFICATIONS CHANGE, PART NO. WILL ALSO CHANGE.

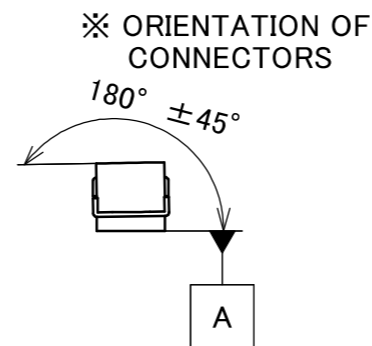
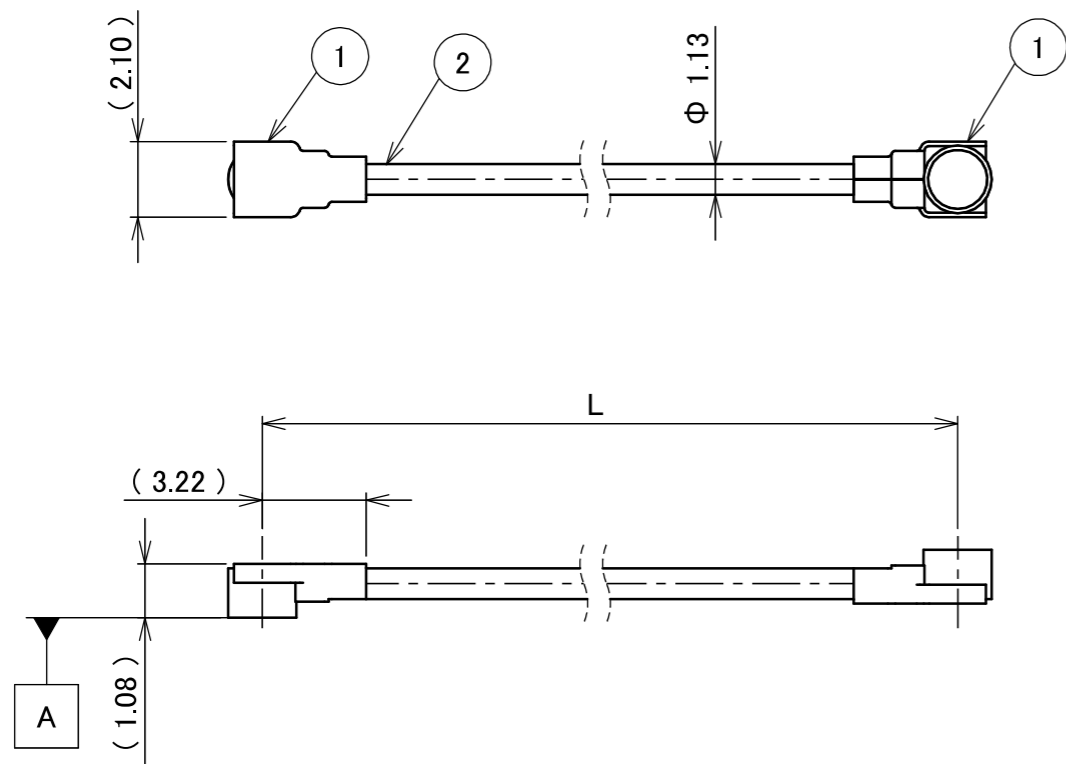

NOTES

1. SUGGESTIONS FOR MATING & UNMATING OPERATION.
  - 1-1. MATING  
MATE THE CONNECTOR VERTICALLY, ALIGNING THE MATING AXIS ON PLUG AND RECEPTACLE. DO NOT SLANT MATE.
  - 1-2. UNMATING
    - 1-2-1.  
UNMATING BY PULLING TOOL.  
[P/N 90609-0001 (MHF 4L), ]  
USE THE PULLING TOOL AS THE FOLLOWING, AND PULL PLUG TO VERTICAL DIRECTION AS DIRECTLY AS POSSIBLE.
  - 1-2-2.  
UNMATING DIRECTLY BY HAND.  
HOLD THE CATCHING AREA ON PLUG AND PULL THE PLUG VERTICALLY.

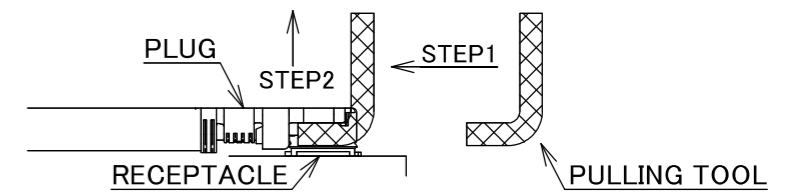

2. PACKING : PLASTIC BAG
3. PERMISSIBLE LOAD ON THE CABLE AFTER MATING

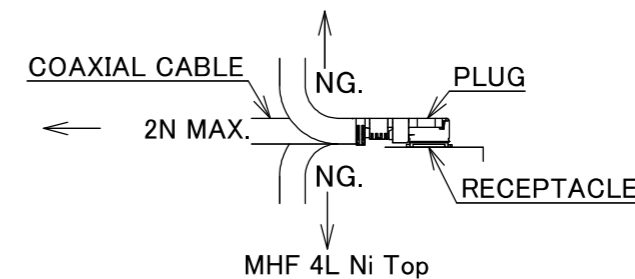
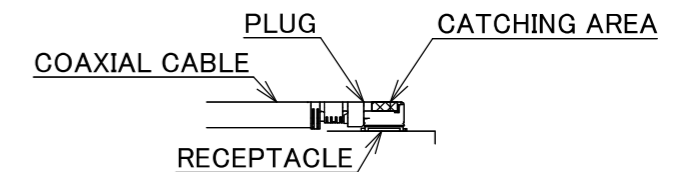

4. CABLE CRIMP STRENGTH : 15N MIN.

2	CABLE	1	AWG#32 Φ 1.13, BRAIDED SHIELD , BLACK
1	CONNECTOR-1, 2	2	MHF 4L Ni Top
NO.	DESCRIPTION	QTY	REMARK

					ANGLE	±2°	6 OVER 30 MAX.	±0.3	PROJECTION	SERIES No.	CUSTOMER COPY			
					6 MAX.	±0.2	30 OVER 120 MAX.	±0.5		H-250077D	I-PEX			
					GENERAL TOLERANCE.				TITLE	SCALE	I-PEX			
					DWG.	M.Toida		DATE	2026/01/30		X:1	I-PEX		
					CHK.	T.Takuno					UNIT	I-PEX		
0	ZH00388	TOI	2026/01/30	-	APP.	K.Yufu			DWG. No.		mm	SIZE	SHEET	REV.
					REVISION RECORD				8-25-0950		A3	1/1	0	



Halogen Free



RoHS Compliant

Confidential C

I-PEX Inc.

QKE-DFE06-02 REV.12