

PART NO.

8-23-0113

PLEASE CONTACT I-PEX FOR REQUESTS OTHER THAN THIS SPECIFICATIONS.
PLEASE NOTE IF SPECIFICATIONS CHANGE, PART NO. WILL ALSO CHANGE.

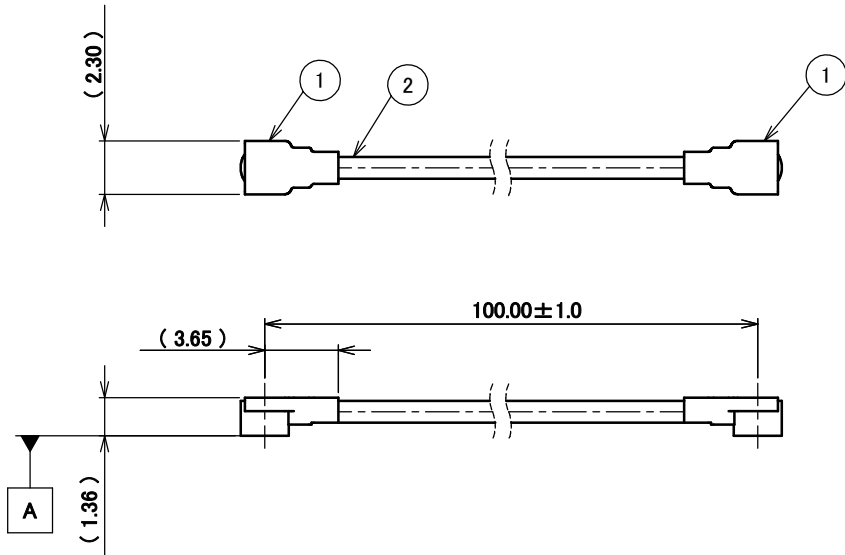

NOTES

1. SUGGESTIONS FOR MATING & UNMATING OPERATION.
 - 1-1. MATING
MATE THE CONNECTOR VERTICALLY,
ALIGNING THE MATING AXIS ON PLUG AND RECEPTACLE.
DO NOT SLANT MATE.
 - 1-2. UNMATING
 - 1-2-1.
UNMATING BY PULLING TOOL.
[P/N 90873-0001 (MHF 4L)]
USE THE PULLING TOOL AS THE FOLLOWING, AND
PULL PLUG TO VERTICAL DIRECTION AS DIRECTLY AS POSSIBLE.

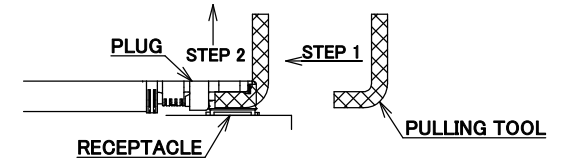

- 1-2-2.
UNMATING DIRECTLY BY HAND.
HOLD THE CATCHING AREA ON PLUG AND PULL THE PLUG
VERTICALLY.

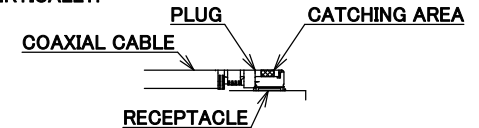

2. PACKING : PLASTIC BAG
3. PERMISSIBLE LOAD ON THE CABLE AFTER MATING

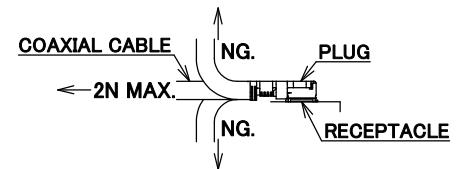

4. CABLE CRIMP STRENGTH : 15N MIN.
5. ORIENTATION OF CONNECTORS : 0° ± 45°

2	CABLE	1	AWG#30 Φ 1.37, BRAIDED SHIELD, BLACK
1	CONNECTOR-1, 2	2	MHF 4L Ni Top
NO.	DESCRIPTION	QTY	REMARK

CONSTRUCTIONS

ANGLE	±2°	6 OVER 30 MAX.	±0.3	PROJECTION	SERIES No.	H-230031J	CUSTOMER COPY
6 MAX.	±0.2	30 OVER 120 MAX.	±0.5	TITLE			
GENERAL TOLERANCE.				⊕	MHF®	X/1	I-PEX
DWG.	M.Toida	DATE	2023/09/25	4L-4L CABLE137-1	UNIT	mm	
CHK.	K.Yufu	APP.	Y.Hashimoto	DWG. No.	8-23-0113	SIZE	A3
REV.	ECN	BY	DATE	APP.		SHEET	1/1
REVISION RECORD						REV.	0



Halogen Free



RoHS Compliant