

Recommended P/N 90582-0300

| | |
|------------|---------|
| PART No. | L |
| 90582-0300 | 300[mm] |
| 90582-0400 | 400[mm] |



Halogen Free



RoHS Compliant

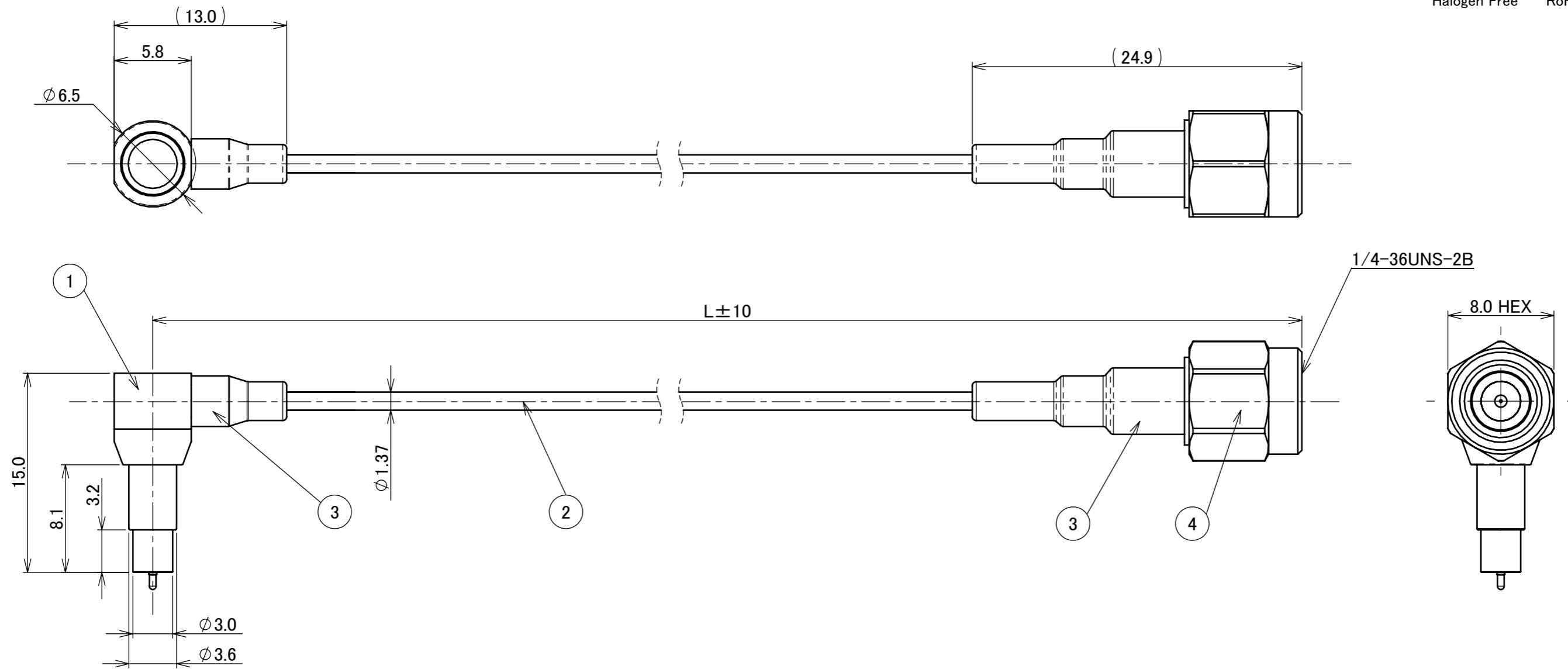

| | | | |
|-----|----------------------|----------|-----------------|
| 4 | SMA-PLUG | - | |
| 3 | HEAT SHRINKABLE TUBE | - | BLACK |
| 2 | COAXIAL CABLE | - | BLACK |
| 1 | INSPECTION PROBE | - | |
| NO. | DESCRIPTION | MATERIAL | FINISH, REMARKS |

| | | | | | | | | | | | | | |
|------|---------|------|------------|------|--------------------|----------|------------------|------------|--|----------------------------|---------------|--------------|-----------|
| 5 | Z220225 | K.M | 2022/03/09 | Y.H | ANGLE | ±2° | 6 OVER 30 MAX. | ±0.3 | PROJECTION ⊕ | SERIES No. R0 | CUSTOMER COPY | | |
| 4 | Z190626 | K.I | 2019/05/09 | Y.H | 6 MAX. | ±0.2 | 30 OVER 120 MAX. | ±0.5 | | | | | |
| 3 | Z190256 | Yufu | 2019/02/28 | Y.H | GENERAL TOLERANCE. | | | | TITLE MHF® -SW23 SMA ADAPTER CABLE | SCALE 3:1 UNIT mm | I-PEX | | |
| 2 | Z140966 | S.H | 2014/08/14 | Tom | DWG. | DATE | | 2012/11/12 | | | | | |
| 1 | Z121013 | H.K | 2012/11/22 | Tom | H.Kon | | | | | | | | |
| 0 | Z12981 | H.K | 2012/11/12 | CHK. | K.Yotsutani | | | | | | | | |
| REV. | ECN | BY | DATE | APP. | APP. | T.Takano | | | DWG. No. | 90582 | SIZE A3 | SHEET 1/2 | REV. 5 |

Confidential C

I-PEX Inc.

QKE-DFE06-02 REV.12

| ITEMS | SPECIFICATION |
|---------------------------------|--|
| APPLICABLE CONNECTOR PART No. | 20549-001E-** |
| RATING FREQUENCY | DC~11GHz |
| OPERATING TEMPERATURE | 233~343K(-40°C~+70°C) |
| VSWR | 1.4 MAX. (DC~3GHz), 1.8 MAX. (3GHz~6GHz), 2.2 MAX. (6GHz~11Hz) |
| DIELECTRIC WITHSTANDING VOLTAGE | AC100V 1min |
| DURABILITY | 1,000 CYCLES |
| PRODUCT SPECIFICATION | PRS-1759 |
| TEST REPORT | TR-12131 |
| INSTRUCTION MANUAL | HIM-13004 |
| APPEARANCE CRITERIA No. | QLS-A*** |

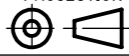
| | | | | | | |
|--------------------|-------|------------------|------|---|------------------|---------------|
| ANGLE | ±2° | 6 OVER 30 MAX. | ±0.3 | PROJECTION  | SERIES No. R0 | CUSTOMER COPY |
| 6 MAX. | ±0.2 | 30 OVER 120 MAX. | ±0.5 | | | |
| GENERAL TOLERANCE. | | | | TITLE MHF® -SW23 SMA ADAPTER CABLE | SCALE | I-PEX |
| DWG. | DATE | | | | | |
| CHK. | | | | | | |
| APP. | | | | | | |
| DWG. No. | 90582 | | | SIZE | SHEET | REV. |
| | | | | A3 | 2/2 | 5 |