

PART No.
82909-100B-02-D

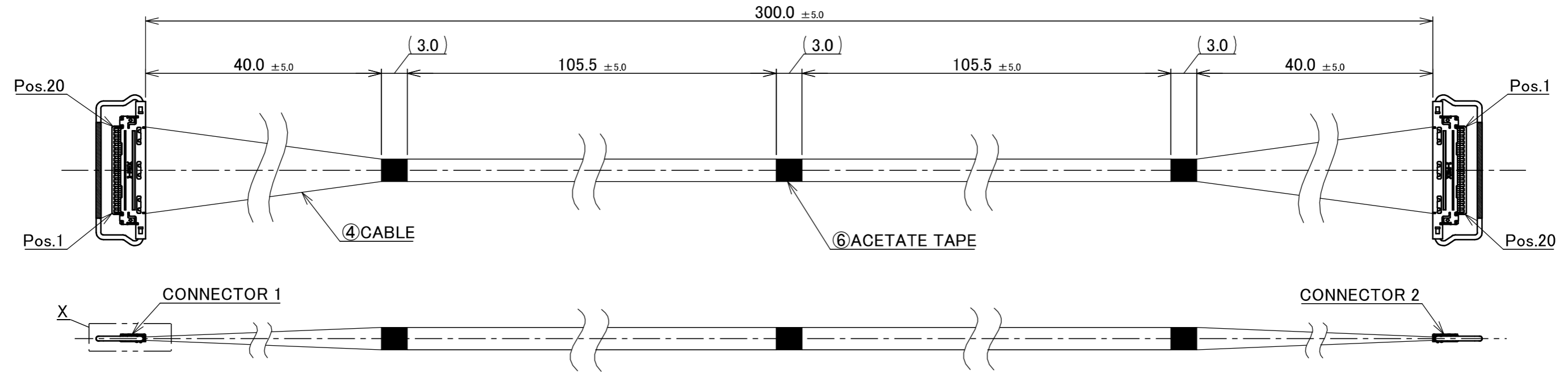

CONNECTOR 1&2
(S=5/1)

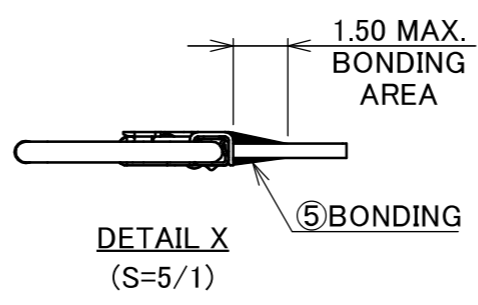
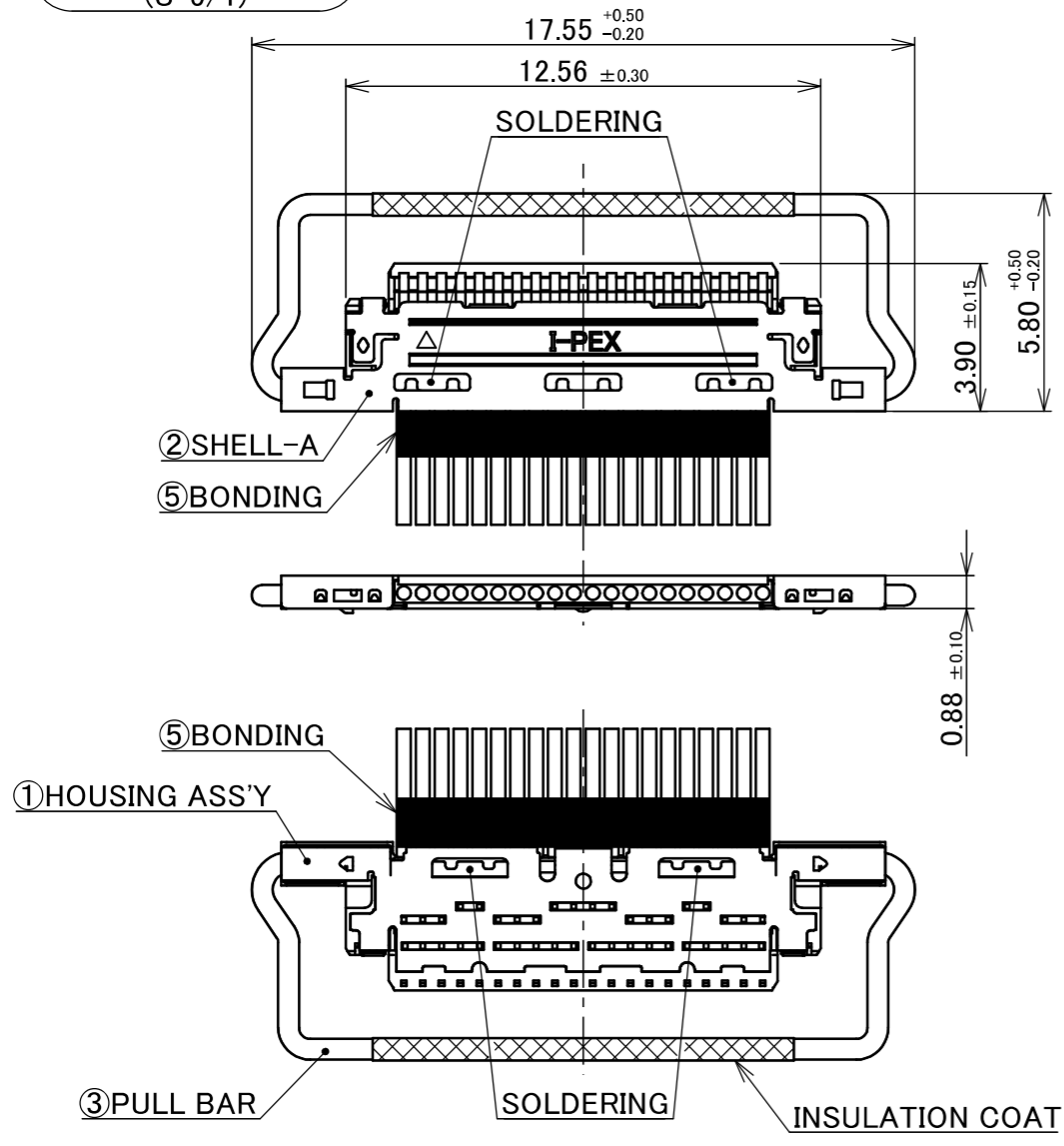

NOTE.
1. TO HANDLE THIS CONNECTOR YOU MUST READ AND FOLLOW THE INSTRUCTION MANUAL BELOW. I-PEX INSTRUCTION MANUAL No.HIM-08004.
2. ELECTRIC CHARACTERISTICS
WITHSTANDVOLTAGE : AC 250V LEAKAGE CURRENT 2.0mA MAX.
INSULATION RESISTANCE : 50MΩ MIN. DC 100V
3. THE OPERATING TEMPERATURE OF THE HARNESS : 80°C MAX.
4. RATING VOLTAGE : 30V

| PIN ASSIGNMENT | | |
|----------------|---|-------------|
| CONNECTOR 1 | CABLE | CONNECTOR 2 |
| 20 | MICRO-COAXIAL CABLE AWG#40 50 OHM, BLUE | 1 |
| 19 | MICRO-COAXIAL CABLE AWG#40 50 OHM, BLUE | 2 |
| · | MICRO-COAXIAL CABLE AWG#40 50 OHM, BLUE | · |
| · | MICRO-COAXIAL CABLE AWG#40 50 OHM, BLUE | · |
| · | MICRO-COAXIAL CABLE AWG#40 50 OHM, BLUE | · |
| 2 | MICRO-COAXIAL CABLE AWG#40 50 OHM, BLUE | 19 |
| 1 | MICRO-COAXIAL CABLE AWG#40 50 OHM, BLUE | 20 |

| NO. | DESCRIPTION | PARTS NO. | QTY | REMARKS |
|-----|---------------|-------------|-----|---|
| 6 | ACETATE TAPE | - | 3 | BLACK |
| 5 | BONDING | - | - | UV GLUE |
| 4 | CABLE | - | 20 | MICRO-COAXIAL CABLE AWG#40 50 OHM, BLUE |
| 3 | PULL BAR | 2576-120-00 | 2 | CONNECTOR 1&2 |
| 2 | SHELL-A | 2574-0202 | 2 | CABLIN [®] -VS PLUG P/N : 20453-220T-03 CONNECTOR TO BE MATED : 20455-020E-66 |
| 1 | HOUSING ASS'Y | 20454-220T | 2 | |

| REVISION RECORD | | | | | GENERAL TOLERANCE. | | PROJECTION | | SERIES No. | | CUSTOMER COPY | |
|-----------------------------|---------|-----|------------|------|--|------|------------------|------|------------|-----------|---------------|-----|
| REV. | ECN | BY | DATE | APP. | ANGLE | ±2° | 6 OVER 30 MAX. | ±0.3 | IH-200016 | IH-200016 | SCALE | 2:1 |
| 0 | ZM00778 | K.B | 2026/04/14 | - | 6 MAX. | ±0.2 | 30 OVER 120 MAX. | ±0.5 | | | | |
| DWG. K.Baba DATE 2026/04/14 | | | | | TITILE CABLIN [®] -VS 20P HARNESS | | DWG. No. 82909 | | SIZE | SHEET | REV. | |
| CHK. R.Takei | | | | | DWG. No. 82909 | | 82909 | | A3 | 1/1 | 0 | |
| APP. T.Masunaga | | | | | DWG. No. 82909 | | 82909 | | A3 | 1/1 | 0 | |

Confidential C

I-PEX Inc.

QKE-DFE06-02 REV.12