

Recommended P/N 20437-0**T-01

PART No.	POS.	A	B	C
20437-030T-*1	30	14.50	10.50	20.80
20437-040T-*1	40	19.50	15.50	25.80
20437-050T-*1	50	24.50	20.50	30.80

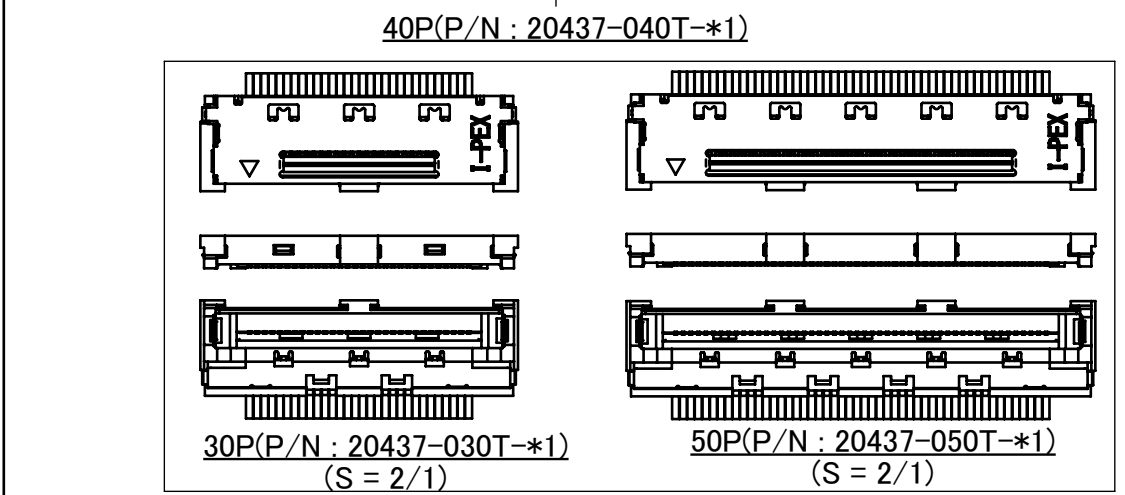

CABLE ASS'Y PART No.	HOUSING ASS'Y PART No.	SHELL-A PART No.	CONTACT FINISH (MATING AREA)
20437-0**T-01	20438-0**T-01	2496-0**	Au 0.10 μm MIN.
20437-0**T-11	20438-0**T-11	2496-0**	Au 0.30 μm MIN.

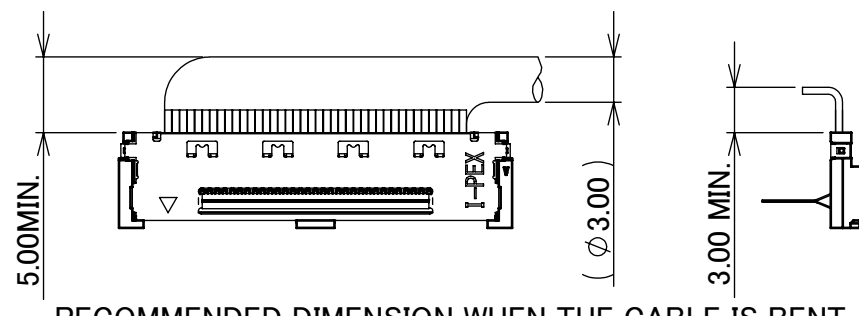
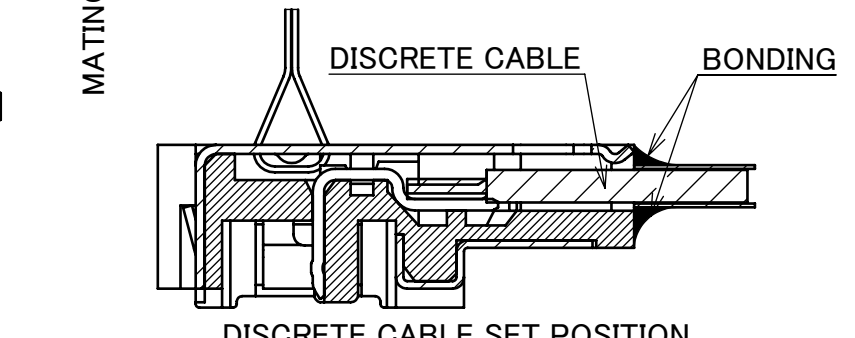
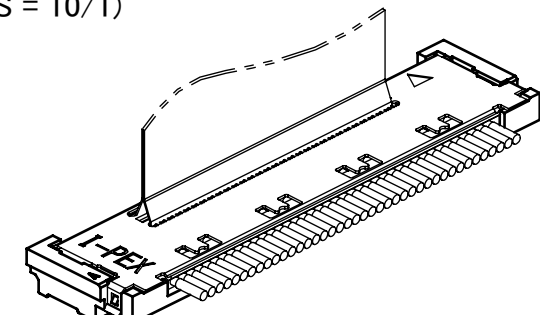
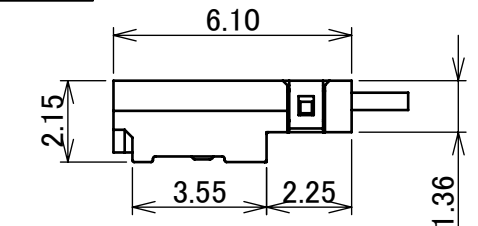
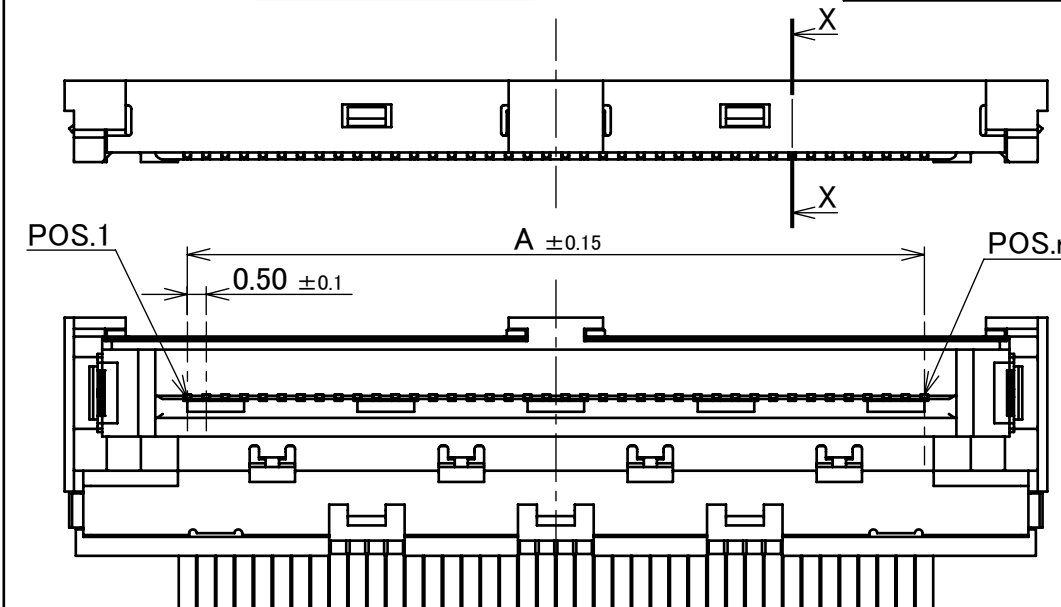
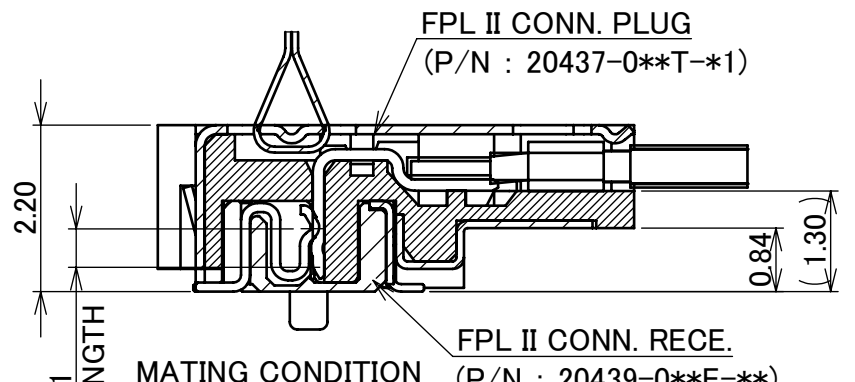
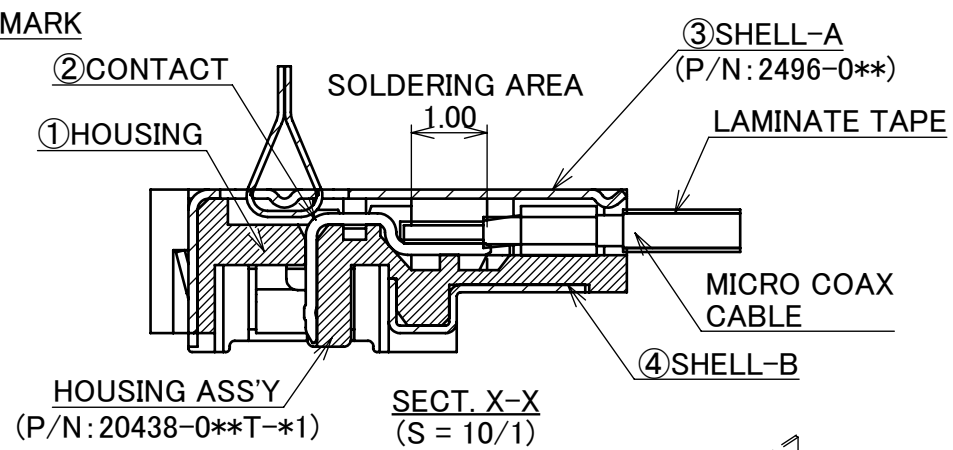
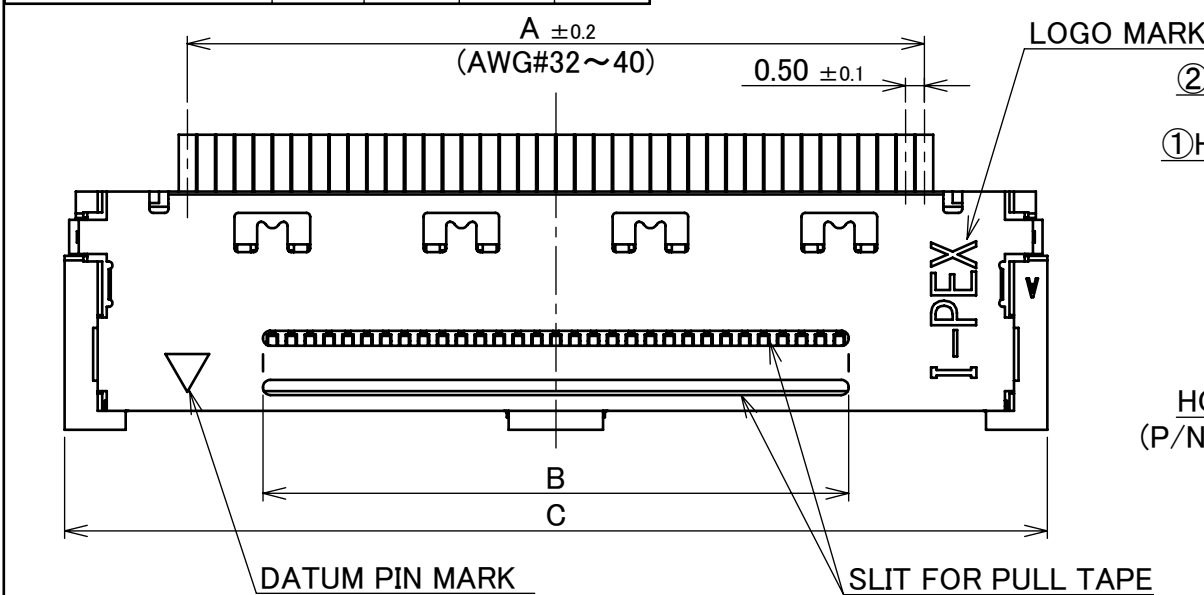

NO.	DISCRIPTION	MATERIAL	FINISH, REMARKS
4	SHELL-B	PHOSPHOR BRONZE	Sn 2.00 μm MIN. OVER Ni 1.00 μm MIN.
3	SHELL-A	PHOSPHOR BRONZE	Sn 2.00 μm MIN. OVER Ni 1.00 μm MIN.
2	CONTACT	PHOSPHOR BRONZE	PART NO. 20437-0**T-01 MATING AREA : Au 0.10 μm MIN. OVER Ni 1.00 μm MIN. OTHER AREA : Au 0.05 μm MIN. OVER Ni 1.00 μm MIN. PART NO. 20437-0**T-11 MATING AREA : Au 0.30 μm MIN. OVER Ni 1.00 μm MIN. OTHER AREA : Au 0.05 μm MIN. OVER Ni 1.00 μm MIN.
1	HOUSING	LCP	UL94V-0, BLACK

REV.	ECN	BY	DATE	APP.	APP.	REVISION RECORD	ANGLE	PROJECTION	SERIES No.	TITLE	SCALE	UNIT	SHEET	REV.
16	Z230076	T.Ono	Jan./19/'23	T.M	ANGLE	±2°	6 OVER 30 MAX.	±0.3	PROJECTION	R5R2	CUSTOMER COPY	5:1	I-PEX	
15	Z220359	T.Ono	Apr./01/'22	H.I	6 MAX.	±0.2	30 OVER 120 MAX.	±0.5				mm		
14	Z211198	T.O	Oct./01/'21	H.I	GENERAL TOLERANCE.									
13	Z191305	Y.Sasa	Sept./27/'19	H.I	DWG.	K.T	DATE	Apr./16/'07						
12	Z190870	Y.Sasa	July/01/'19	H.I	CHK.	Y.H								
11	Z181398	H.A	Oct./26/'18	Y.S	APP.	T.H								
REV.	ECN	BY	DATE	APP.	APP.				DWG. No.	20437		A3	1/3	16

CAUTION VISIT OUR WEBSITE FOR LATEST VERSIONS OF INSTRUCTION MANUAL NO. HIM-09007 TO HANDLE THE PRODUCT PROPERLY AND SAFELY.

ITEMS	SPECIFICATION
APPLICABLE CABLE	MICRO COAX : AWG# 40, 38, 36, 34, 32 DISCRETE : AWG# 36, 34, 32 TWINCOAX : AWG# 40
RATING VOLTAGE	100V AC (PER CONTACT PIN)
RATING AMPERAGE (FOR CONTACT)	0.3A AC/DC [AWG#40] PER CONTACT PIN / UP TO 50 CONTACTS 0.6A AC/DC [AWG#38] PER CONTACT PIN / UP TO 6 CONTACTS 0.8A AC/DC [AWG#36] PER CONTACT PIN / UP TO 4 CONTACTS 1.0A AC/DC [AWG#34, 32] PER CONTACT PIN / UP TO 7 CONTACTS TESTING BY REAL MACHINE IS RECOMMENDED BECAUSE TEMPERATURE RISE MAY AFFECTED BY ACTUAL SITUATION.
OPERATING TEMPERATURE	233~358K(-40°C~+85°C)
OPERATING HUMIDITY	85% MAX.(NON-CONDENSING)
CONTACT RESISTANCE	INITIAL : 145mohm MAX.(AWG#32) / AFTER TEST : \triangle 40mohm MAX. 185mohm MAX.(AWG#34) 210mohm MAX.(AWG#36) 335mohm MAX.(AWG#38) 575mohm MAX.(AWG#40)
GROUND SHELL RESISTANCE	INITIAL : 50mohm MAX. / AFTER TEST : \triangle 40mohm MAX.
INSULATION RESISTANCE	INITIAL : 1000Mohm MIN. / AFTER TEST : 500Mohm MIN.
DIELECTRIC WITHSTANDING VOLTAGE	AC250V 1min
DURABILITY	30 CYCLES
MATING FORCE (INITIAL / AFTER TEST)	30P : 50.0N MAX. / 40P : 60.0N MAX. / 50P : 70.0N MAX.
UNMATING FORCE (INITIAL / AFTER TEST)	30P : 5.0N MIN. / 40P : 6.0N MIN. / 50P : 7.0N MIN.
CABLE RETENTION FORCE	30.0N MIN.
COPLANARITY	0.10 MAX.
PRODUCT SPECIFICATION	PRS-1383
TEST REPORT	TR-07048
PACKING STANDARD	PLUG HOUSING ASS'Y : 300-584 / PLUG SHELL-A : 300-585
INSTRUCTION MANUAL	HIM-09007
ASSEMBLY MANUAL	ASM-07005
APPEARANCE CRITERIA No.	QLS-A***

ANGLE	$\pm 2^\circ$	6 OVER 30 MAX.	± 0.3	PROJECTION 	SERIES No. R5R2	CUSTOMER COPY		
6 MAX.	± 0.2	30 OVER 120 MAX.	± 0.5					
GENERAL TOLERANCE.				TITLE FPL II CONN. PLUG CABLE ASS'Y	SCALE 	I-PEX		
DWG.	DATE							
CHK.								
APP.								
				DWG. No.	20437	SIZE A3	SHEET 2/3	REV. 16

PART No.	POS.	A	D	E
20437-030T-*1	30	14.50	15.70	17.50
20437-040T-*1	40	19.50	20.70	22.50
20437-050T-*1	50	24.50	25.70	27.50

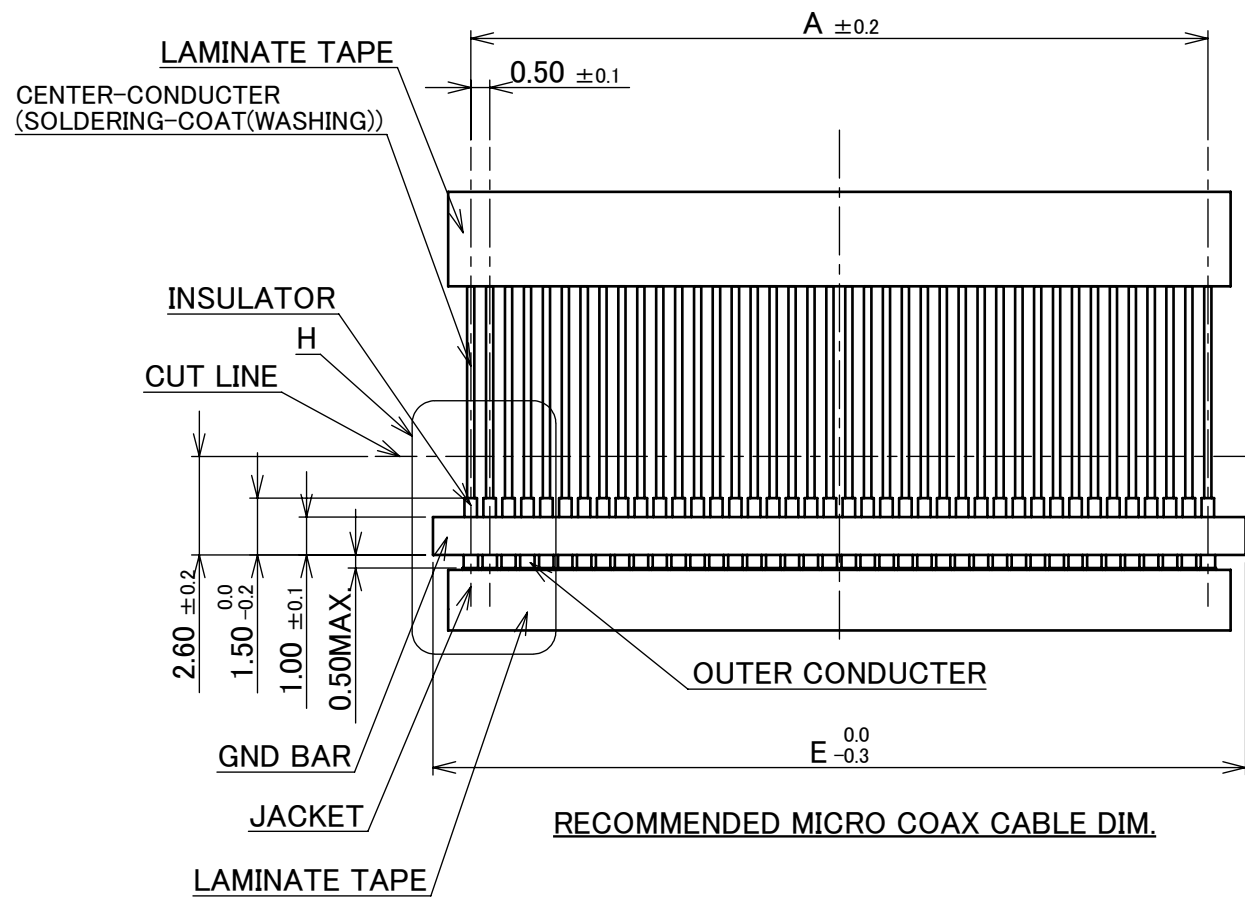

RECOMMENDED MICRO COAX CABLE DIM.

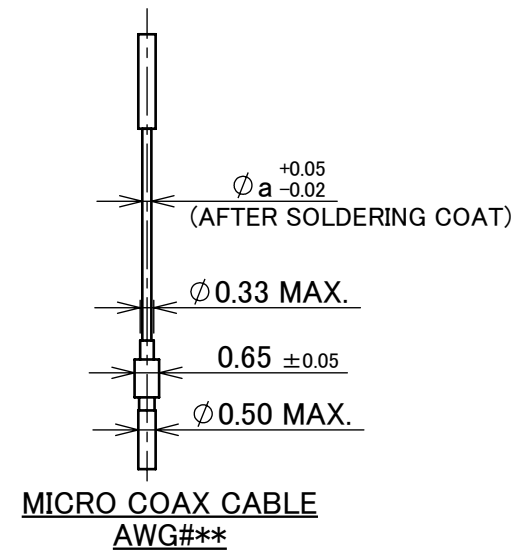

CHARACTERISTIC IMPEDANCE MATCHING MICRO COAX CABLE

	a
#36	0.15
#38	0.12
#40	0.09

CHARACTERISTIC IMPEDANCE UN-MATCHING MICRO COAX CABLE

	a
#32	0.24
#34	0.192

MICRO COAX CABLE #32, 34 : NOT RECOMMENDED FOR HIGH SPEED SIGNAL TRANSFER

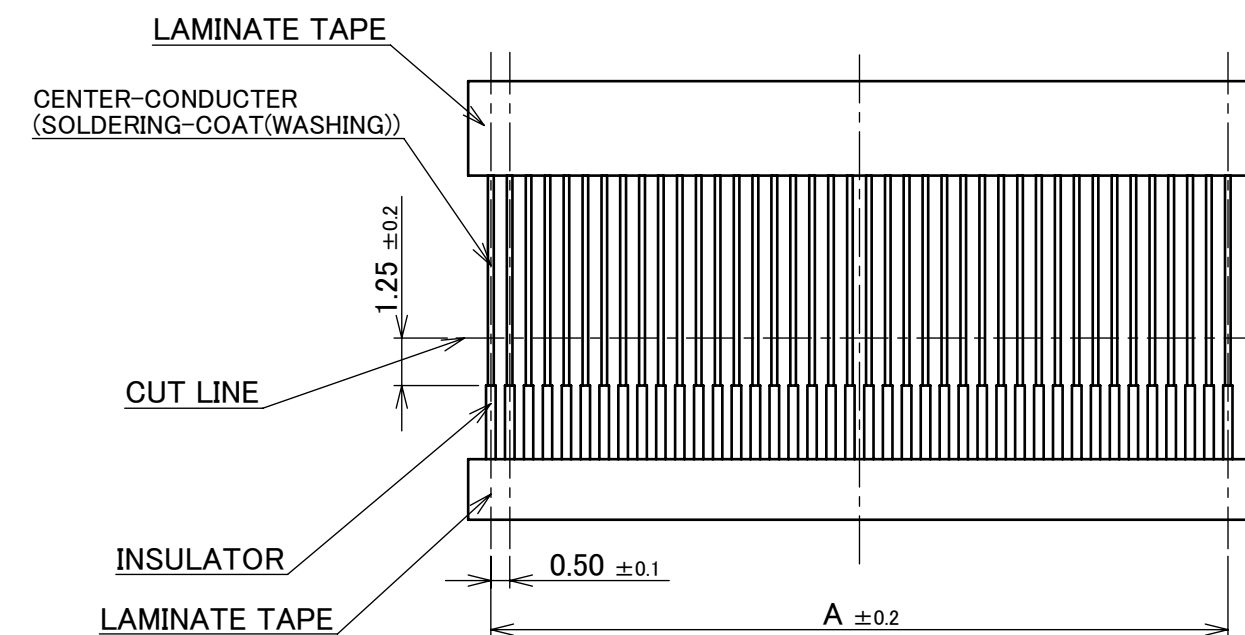
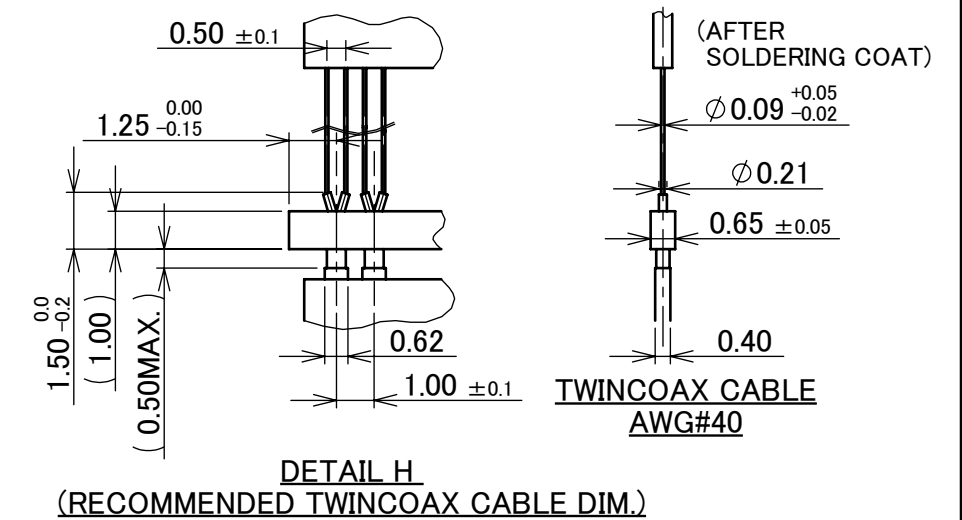

RECOMMENDED DISCRETE CABLE DIM.

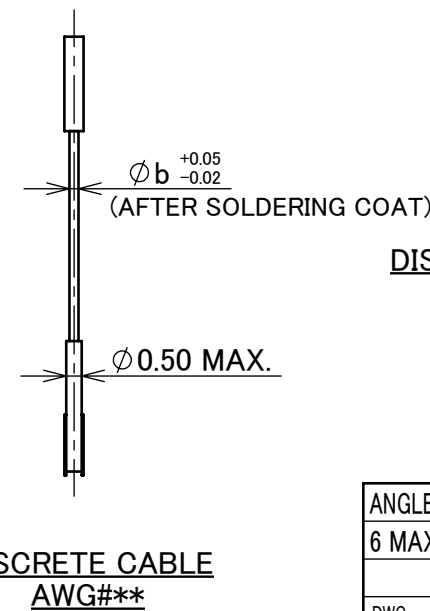

DISCRETE CABLE DIMENSION

	b
#32	0.24
#34	0.192
#36	0.15

ANGLE	±2°	6 OVER 30 MAX.	±0.3	PROJECTION ⊕	SERIES No. R5R2	CUSTOMER COPY						
	6 MAX.	±0.2	30 OVER 120 MAX.						±0.5			
GENERAL TOLERANCE.				TITLE		SCALE	I-PEX					
DWG.	DATE			FPL II CONN. PLUG CABLE ASS'Y		5:1						
CHK.						UNIT						
APP.				DWG. No. 20437		mm				SIZE	SHEET	REV.
						A3	3/3	16				